



eqssTM Gen-3 LMS Telehandler Load Management System

Installation Manual for TL30.60



*****Do Not Swap Components between Gen3-LMS kits*****

When installing multiple Gen3-LMS kits, make sure the serial number on the sticker matches the serial number on the machine.

*****Failure To Follow Installation Manual Will Void Warranty*****

Documentation Conventions

The list below highlights important documentation conventions.



Text presented in this manner is intended to provide the user with some general information. The user should ensure information presented in this manner is clearly understood.



Text presented in this manner provides the user with information to assist in completion of the current procedure being explained.



Text presented in this manner indicates that a failure to follow directions could result in damage to equipment, loss of information, bodily harm, or loss of life.

Important Information

Information contained in this publication regarding this device's applications and the like is provided only for your convenience and may be superseded by updates. It is your responsibility to ensure that the application or our equipment meets with your specifications.

EQUIPMENT SAFETY SYSTEMS MAKE NO REPRESENTATIONS OR WARRANTIES OF ANY KIND WHETHER EXPRESS OR IMPLIED, WRITTEN OR ORAL, STATUTORY OR OTHERWISE, RELATED TO THE INFORMATION, INCLUDING BUT NOT LIMITED TO, IT'S CONDITION, QUALITY, PERFORMANCE, MERCHANTABILITY OR FITNESS FOR PURPOSE.

Equipment Safety Systems disclaims all liability arising from this information and its use. Use of Equipment Safety Systems' products as critical components in life support systems is not authorised except with express written approval by Equipment Safety Systems. No licenses are conveyed, implicitly or otherwise, under any Equipment Safety Systems intellectual property rights.

Table of Contents

Tools Required for Installation.....	5
Installation Index.....	6
Covers.....	9
Cable Reeler Installation.....	11
Cable Reeler Mounting Position.....	13
Pressure Sensor Installation.....	14
Main Cylinder Pressure Sensors.....	14
Compensation Pressure Sensors.....	17
Reverse Camera.....	18
Can Pressure Input Module (CPIM).....	20
Signal Light Installation.....	22
Forward Camera.....	25
External Cable Completion.....	27
Display Installation.....	31
User Input Control.....	32
Can Cabin Interface Module (CCIM).....	33
Machine Connections.....	34
Cabin Loom.....	37
Finalisation.....	40
Set Time & Sensor Calibration.....	43
Schematics.....	46
Appendix A: Attaching Display Connectors.....	49
Appendix B: Reattach Ferrites.....	53
Indexes and Tables.....	54

Tools Required for Installation

The tools required to perform the installation of the TSS are listed below

- Pencil or Texta
- Drill
- Drill bits
 - 3.3 mm
 - 4.5 mm
 - 5 mm
 - 6.8 mm
 - 8.5 mm
- Centre punch
- Tap T-Handle
- Taps
 - M6
 - M8
- Drill and tap oil
- Metric Allen keys
- Phillips Head screw driver
- Spanners and sockets
 - 7 mm
 - 10 mm
 - 13 mm
- Loctite thread locker
- Side cutters
- Stanley knife
- Crimpers
- Wire strippers
- Torque Wrench

Installation Index

The components and cables of the Gen-3 Telehandler Load Management System are outline in the tables below. The following pages show where the components are installed and the cable routing.

See the appropriate manual section for a detailed installation description for each component.



Refer to this section for any component placement or cable routing issues

<i>Item</i>	<i>Component Description</i>
1	Cable Reeler
2	Main Lift Cylinder Pressure Sensors
3	Compensation Cylinder Pressure Sensors
4	Can Pressure Input Module (CPIM)
5	Cutout Connections
6	Lock Pin Release Connection
7	Forward Camera
8	Signal Light
9	Rear Camera

Table 1: Component Installation Index

<i>Colour</i>	<i>Cable Description</i>
Light Purple	Boom Cable
Dark Green	Main Cylinder Pressure Sensor Cables
Dark Blue	Compensation Cylinder Pressure Sensors Cables
Red	Cutout Harness
Orange	Lock Pin Release Harness
Light Green	Forward Camera Cable
Brown	Signal Light Cable
Light Blue	Rear Camera Cable
Dark Purple	CCIM Cable

Table 2: Cable Installation Index





Illustration 1: Machine Boom



Illustration 2: Machine Chassis

Covers

Remove the following covers before starting the installation

<i>Step</i>	<i>Description</i>	<i>Diagram</i>
1.	Remove the cover behind the cabin in front of the rear left wheel.	
2.	Remove the covers underneath the boom	
3.	Remove the cover in front of the cabin behind the front left wheel.	



<i>Step</i>	<i>Description</i>	<i>Diagram</i>
4.	Remove the cover under the steering wheel.	
5.	Undo the bolts attaching the dashboard.	

Table 3: Cover removal

Cable Reeler Installation

The cable reeler is used to measure the boom extension to determine the maximum lifting capacity.



A false N07 fault can occur if the boom jumps off the stow switch due to pressurising the hydraulic system and without operating the boom extension control. Ensure the stow switch arm is correctly adjusted to prevent this error.

<i>Step</i>	<i>Description</i>	<i>Diagram</i>
1.	<p>Drill the holes for the cable reeler mounting plate according to the mounting diagram on page 13.</p> <p>Mount using the supplied M8 x 30 mm bolts, nuts and washers.</p>	
2.	<p>Drill and tap an M8 hole for the cable anchor. Ensure the cable anchor is positioned so the cable runs in line with the boom.</p> <p>Mount the cable anchor and attach the cable.</p>	
3.	<p>Drill and tap the M6 holes for the stow switch trigger bracket.</p> <p>Mount the stow switch trigger bracket using the supplied M6 x 12 mm bolts and washers.</p> <p>Adjust the length of the trigger plate to ensure the stow switch is pressed when the boom is retracted.</p>	



<i>Step</i>	<i>Description</i>	<i>Diagram</i>
4.	Connect the supplied M12 10 metre cable (CB001027) into the cable reeler connection.	
5.	<p>Run the cable under the boom and cable tie to the existing cable for the boom lights every 500 mm down the boom.</p> <p>Cable tie to the flexible hydraulic hoses down to the chassis. Make sure the cable isn't pinched or stretched when the boom is raised or lowered.</p> <p>Cable tie with the other cables during External Cable Completion on page 27.</p>	

Table 4: Cable Reeler Installation

 For further details on running the boom cable refer to the Installation Index on page 6

Cable Reeler Mounting Position

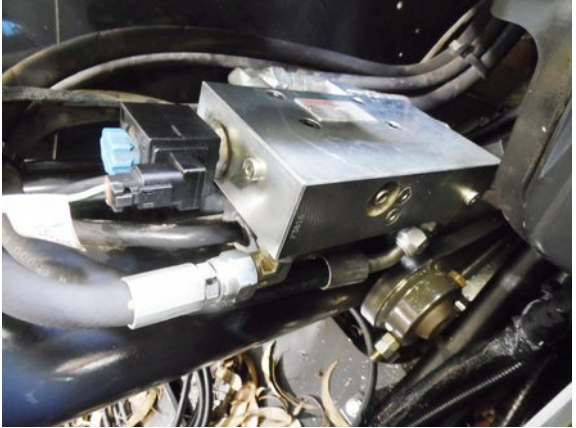
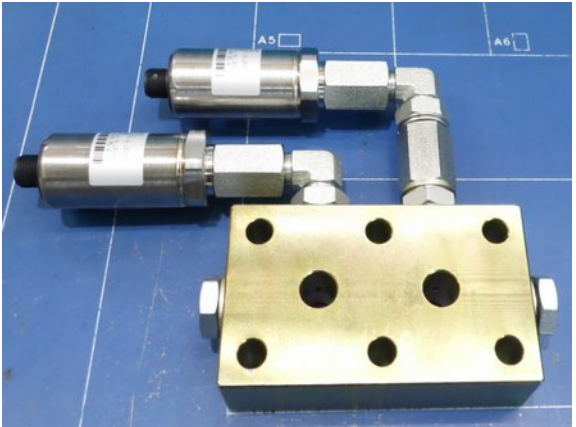



Illustration 3: Cable Reeler Mounting Position

Pressure Sensor Installation

The hydraulic pressure sensors are used to measure the lifting load of the telehandler.

Main Cylinder Pressure Sensors

Step	Description	Diagram
1.	<p>Raise the boom to approximately 40 degrees.</p> <p>Support and secure the boom using an A Frame or similar apparatus. It must support at least 2 tons.</p> <p>Apply the handbrake and insert chock under wheels.</p> <p>Remove the hose connections into the hydraulic manifold block.</p>	
2.	<p>Release the bolts attaching the manifold block to the cylinder.</p> <p>Removing the bolts in the manifold block will release the hydraulic pressure which may result in a spray of oil.</p> <p>Secure the supplied pressure manifold plate to the existing manifold and through to the cylinder using the supplied bolts and seals. Tighten the 12.9 grade bolts for the manifold to 41 NM using a torque wrench.</p> <p>Reinstall the manifold block to the cylinder and reattach the hoses.</p>	 <p data-bbox="863 1442 1225 1473">Supplied Manifold Plate</p> 

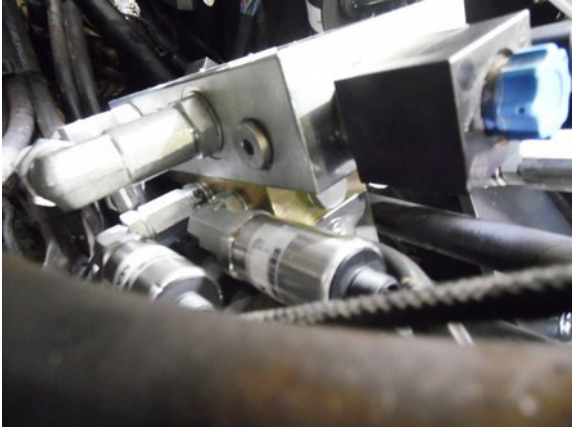
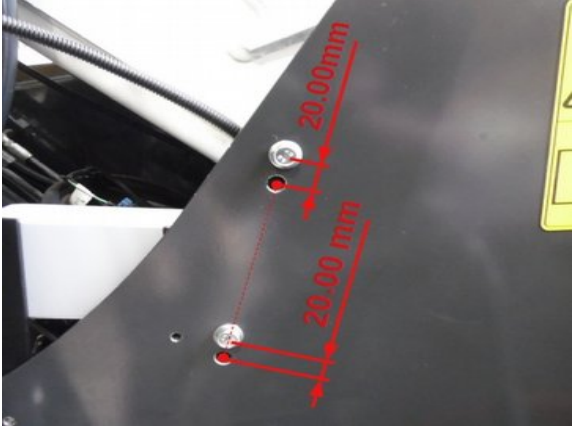
<i>Step</i>	<i>Description</i>	<i>Diagram</i>
3.	<p>Ensure the hydraulic hoses are not resting on the pressure sensors.</p> <p>Start the machine, pressurise the boom and check for leaks and check for clearance.</p>	 <p>Ensure hoses do not rest on pressure sensors.</p>
4.	<p>Shift the rear bracket, that holds the relays and fuses located behind the cabin, upward 20mm following the same centre-line as the current holes.</p> <p>This step is done to ensure the Manifold does not hit the bracket.</p> <p>***** !WARNING! THIS STEP MUST BE PERFORMED TO AVOID COLLISION OF MANIFOLD AGAINST REAR BRACKET *****</p>	

<i>Step</i>	<i>Description</i>	<i>Diagram</i>
5.	<p>Connect the supplied M12 4 metre cables (CB001026) into each of the pressure sensors.</p> <p>Cable tie the pressure sensor cable to the flexible hydraulic hoses connected to the main lift cylinder. Make sure the cable isn't pinched or stretched when the boom is raised or lowered.</p> <p>Run the cables towards the rear of the machine and cable tie with the other cables during External Cable Completion on page 27.</p> <p>Ensure the pressure sensors and cables do not collide with the boom and chassis structures and the cables do not stretch or pinch when the boom is raised and lowered.</p>	 <p>View from under the boom</p>

Table 5: Pressure Sensor Installation

Compensation Pressure Sensors



<i>Step</i>	<i>Description</i>	<i>Diagram</i>
1.	<p>Undo the flexible hydraulic hose connections into the compensation cylinder.</p> <p>Install the supplied head and rod pressure sensors and tee connections as shown and reconnect the flexible hydraulic hose.</p> <p>Ensure the pressure sensors don't hit when the boom is raised and lowered.</p> <p>Start the machine, pressurise the boom and check for leaks and check for clearance.</p>	 <p>View from under the boom behind the rear left wheel.</p>
2.	<p>Connect the supplied M12 4 metre cables (CB001026) into each of the pressure sensors.</p> <p>Cable tie the pressure sensor cables to the flexible hydraulic hoses connected to the compensation cylinder down to the chassis. Make sure the cable isn't pinched or stretched when the boom is raised or lowered.</p> <p>Run the cables towards the rear of the machine and cable tie with the other cables during External Cable Completion on page 27.</p>	 <p>View from under the boom behind the rear left wheel.</p>

Table 6: Compensation Pressure Sensor Installation

Reverse Camera

The rear camera video is displayed on the screen when the machine is in reverse gear to allow the operator to see behind the telehandler while reversing.

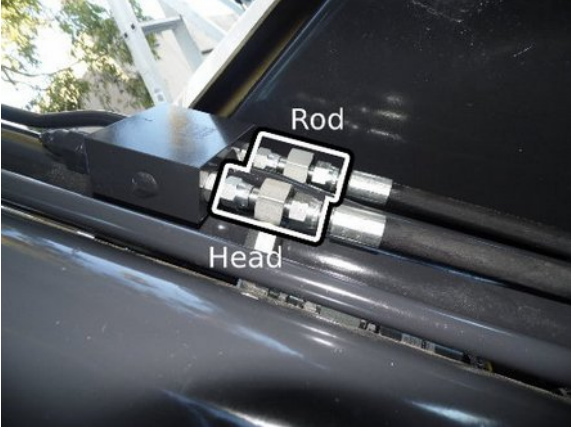
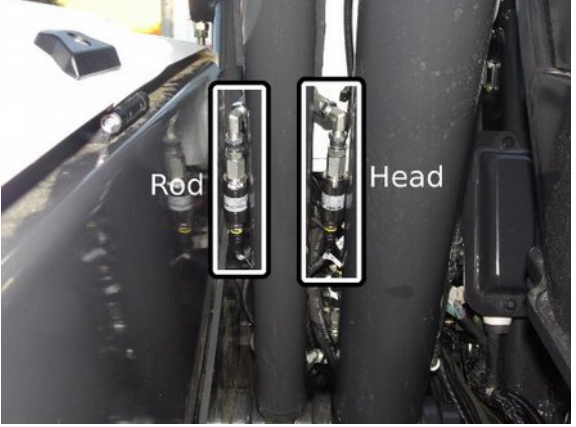
 Do not disconnect the camera power connection while the system is operating as this can damage the fuse.



<i>Step</i>	<i>Description</i>	<i>Diagram</i>
1.	Drill two M6 holes to mount the camera in the location shown.	
2.	<p>Connect the camera power and signal connectors to the supplied 5m camera cable (CB001032).</p> <p>Note; The white connector is not used.</p> <p>Secure the camera cable to the license plate light harness using cable ties.</p> <p>Run the remainder of the cable towards the cabin and insert into snake tube with the cabin cable during External Cable Completion on page 27.</p>	

Table 7: Reverse Camera Installation

 The camera's viewing angle may need to be adjusted once the system is installed and the display is operational.



For further details on running the camera cable refer to the Installation Index on page 6

Can Pressure Input Module (CPIM)

The CPIM is responsible for processing the information send from the pressure sensors.



Accidentally swapping the pressure sensor connections will not damage the system.



Do not plug the pressure sensor cable into the far right side boom cable. This will damage the system.

<i>Step</i>	<i>Description</i>	<i>Diagram</i>
1.	<p>The CPIM module is mounted on the inside of the chassis just behind the cabin.</p> <p>Place the CPIM module on the outside of the chassis and mark the drill hole location. Ensure the location will allow enough clearance to mount the CPIM and attach the M12 cables at the bottom and sides.</p> <p>Drill two M8 holes through the side of the chassis and mount the CPIM using the supplied bolts.</p>	

<i>Step</i>	<i>Description</i>	<i>Diagram</i>
2.	<p>Connect the cables for the pressure sensors and boom cable to the CPIM according to the labels on the CPIM sticker</p> <p>Note: The CCIM cable will be installed during External Cable Completion on page 27.</p>	



Table 8: Can Pressure Input Module (CPIM) Installation



Signal Light Installation

The signal light warns other workers when the telehandler is lifting loads close to its maximum capacity.



Ensure the power supply voltage is greater than 13.5V otherwise the signal light may not illuminate correctly.

<i>Step</i>	<i>Description</i>	<i>Diagram</i>
1.	<p><u>Windshield Guard</u></p> <p>Mount the signal light to the top windscreen guard using the supplied p-clips.</p>	 <p>View from on top of the cabin</p>
2.	<p><u>Without Windshield Guard</u></p> <p>Magnetically mount the signal light of the top of the roof as shown.</p>	

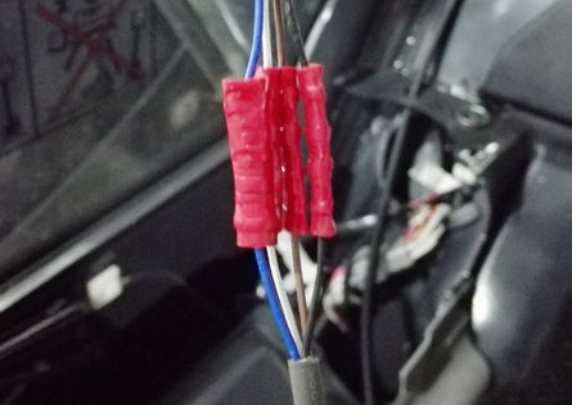
<i>Step</i>	<i>Description</i>	<i>Diagram</i>
3.	Run the signal light cable down towards the cabin grommet and secure in place using the cable tie adhesive strips.	
4.	<p>Inside the cabin remove the cover on the roof to access the cabin grommet.</p> <p>Cut 200mm from the connector end of the light tower cable in order to feed the cable through the rear roof grommet. It will be re-attached to the connector at a later stage.</p>	
5.	Run the end of the cable through the grommet leading into the cabin and feed it through the grommet out to the top of the roof inside the cabin.	
6.	<p>Reconnect the 4 wire cable using the supplied crimp joiners.</p> <p>The snake tube will need to be removed to run the cable through the grommet. Once all the cable has been feed into the cabin, reattach the snake tube starting where the cable runs out the grommet from the roof.</p>	



<i>Step</i>	<i>Description</i>	<i>Diagram</i>
7.	Run the signal light cable along the roof to the other side of the cabin.	
8.	<p>Run the cable from the roof and secure in place using the cable tie adhesive strips.</p> <p>Run the cable under the plastics covers to the dashboard, to connect into the CCIM.</p>	

Table 9: Signal Light Installation

Forward Camera

The forward camera video is displayed on the screen when the machine is in forward gear to allow the operator to see past the boom to obstructions that would damage the right front tyre.

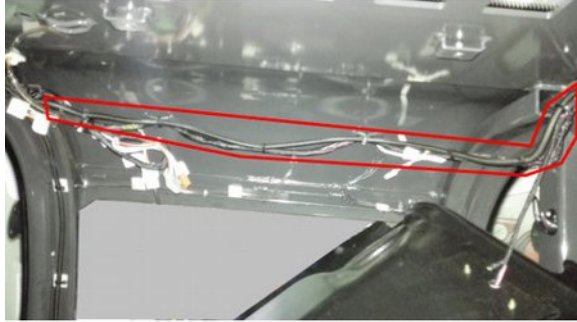

Do not disconnect the camera power connection while the system is operating as this can damage the fuse.



<i>Step</i>	<i>Description</i>	<i>Diagram</i>
1.	<p>Mount the camera to the side mirror post using the p-clips as shown.</p> <p>Secure using two M6 nuts.</p>	
2.	<p>Connect the camera power and signal connectors to the supplied 5m camera cable (CB001032).</p> <p>Note; The white connector is not used.</p> <p>Run the cable along the same path as the headlight cable through the headlight post.</p> <p>Run the remainder of the cable towards the cabin following the headlight cable and insert into cabin during External Cable Completion on page 27.</p>	

Table 10: Forward Camera Installation





The camera's viewing angle may need to be adjusted once the system is installed and the display is operational.









For further details on running the camera cable refer to the Installation Index on page 6

External Cable Completion

All external cabling is completed in this step.

<i>Step</i>	<i>Description</i>	<i>Diagram</i>
1.	Locate the cable entrance hole from the inside of the cabin to the outside of the chassis, located inside the dashboard to outside the front of the cabin.	 <p data-bbox="858 875 1342 943">View from behind the front left wheel towards the cabin</p>
2.	Run the two pin connector pairs from the cutout and lock pin release harnesses through the connector hole from inside the cabin to the outside of the chassis.	
3.	Connect the supplied M12 4 metre cable (CB001026) into the right side of the CPIM for the CCIM cable.	

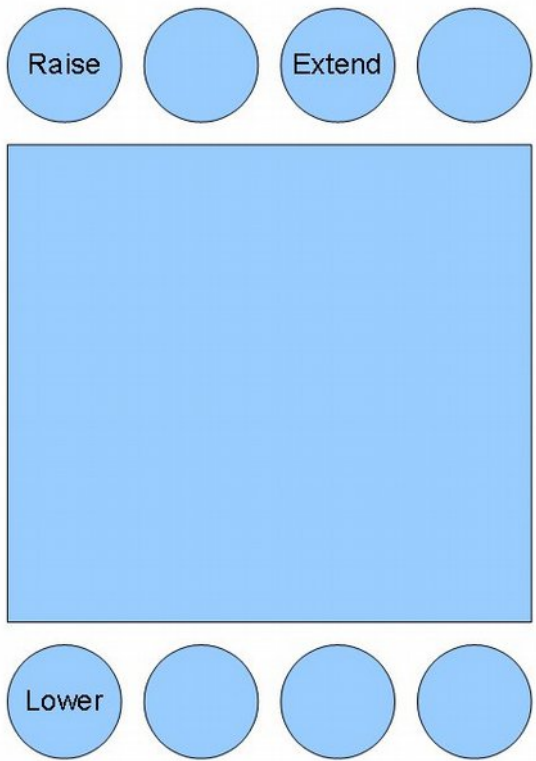
<i>Step</i>	<i>Description</i>	<i>Diagram</i>
4.	<p>Run the cutout and lock pin release harnesses along the same path under the chassis covers as the existing electrical harnesses and hydraulic lines towards the spool assembly at the rear of the machine.</p> <p>Run the CCIM and rear camera cables along the same path as the existing electrical harnesses and hydraulic lines towards and through the hole into the cabin.</p>	
5.	<p>Run the two pin connectors on the lock pin release harness up to the lock pin release solenoid valve and secure in place using cable ties.</p> <p>This will be connected into the solenoid valve during Finalisation on page 40.</p>	
6.	<p>Run the pair of two pin connectors on the height limit cable from out the side of the CPIM module and the two pin connectors from the cutout harness through the hole in the chassis to the spool assembly.</p>	

<i>Step</i>	<i>Description</i>	<i>Diagram</i>
7.	<p>Connect into the spool assembly as shown and secure in place using cable ties.</p> <p>Once secure remove the connections so that the boom will function.</p> <p>These will be reconnected into the solenoid valves during Finalisation on page 40.</p>	 
8.	<p>Coil up the additional cabling for the pressure sensor, CCIM and boom cables and store underneath the CPIM.</p>	 <p>View from behind the cabin</p>

<i>Step</i>	<i>Description</i>	<i>Diagram</i>
9.	<p>Run the CCIM, signal light and camera cables up through the hole into the cabin.</p> <p>Note: Pull a short length of cable through into the cabin. Store excess cable under the covers below the boom, ensure they will not wrap around the drive shaft.</p>	

Table 11: External Cable Completion

Display Installation

The display shows the current safety status of the telehandler.



<i>Step</i>	<i>Description</i>	<i>Diagram</i>
1.	Remove the rear mirror from the right column.	
2.	<p>Using the supplied M3 screws, Plastic Sleeve, and bolts, mount the Display Bracket to the same mounting location of the removed rear-view mirror.</p> <p>Mount the display to the installed display-bracket and connect the 2 X M12 screw-lock connectors to the back of the display.</p>	

Table 12: Display Installation



Adjust the display bracket for optimal viewing angle once the display is powered



If the M12 screw lock connectors on the display are over tightened it will twist the connector pins attaching the connector to the PCB. See Appendix A: Attaching Display Connectors on page 49 for the correct method of attaching to the display connectors.

User Input Control

The user input control consists of a single dial switch mounted in the dashboard.

<i>Step</i>	<i>Description</i>	<i>Diagram</i>
1.	<p>Drill a 34 mm hole into the location shown shown below the park brake switch.</p> <p>Install the user input control dial in the dashboard, aligned so the Enter cap is facing up.</p>	

Table 13: User Input Control Installation



If the M12 screw lock connectors on the display are over tightened it will twist the connector pins attaching the connector to the PCB. See Appendix A: Attaching Display Connectors on page 49 for the correct method of attaching to the display connectors.

Can Cabin Interface Module (CCIM)

The CCIM connects the system into the machine electronics.



<i>Step</i>	<i>Description</i>	<i>Diagram</i>
1.	<p>Position the backup battery (shown behind the CCIM) to the side panel underneath the dashboard using double sided velcro tape.</p> <p>Position the CCIM in front of the backup battery using double sided velcro tape.</p> <p>Remove the battery and CCIM from the velcro to allow the connections to be completed. Reattach to the velcro in the section Finalisation on page 40.</p>	 <p>View from inside dashboard</p>

Table 14: CCIM Installation



Machine Connections

The following procedures connect the safety systems to the existing electronics in the machine.

 Isolate the main battery before starting the machine connections

 After completing the machine connections the boom can not be moved until the installation is complete

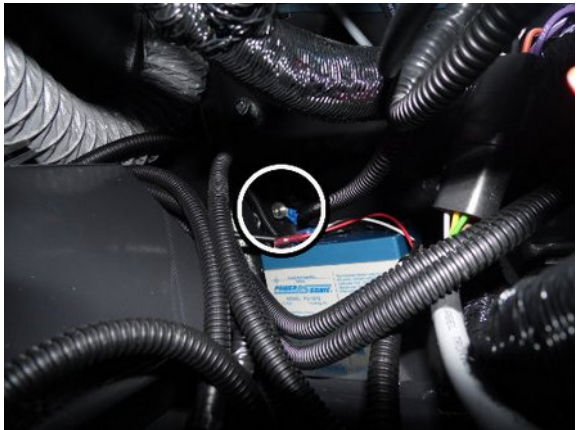
<i>Step</i>	<i>Description</i>	<i>Diagram</i>								
1.	<p>Remove a blanking switch plate from the removable dashboard panel and install the camera switch.</p> <p>Connect the male spade connections from the machine input harness to the camera switch according to the table below.</p> <table border="1"> <thead> <tr> <th><u>Wire Colour</u></th> <th><u>Terminal</u></th> </tr> </thead> <tbody> <tr> <td>Blue</td> <td>1</td> </tr> <tr> <td>Black</td> <td>2</td> </tr> <tr> <td>Green</td> <td>3</td> </tr> </tbody> </table>	<u>Wire Colour</u>	<u>Terminal</u>	Blue	1	Black	2	Green	3	
<u>Wire Colour</u>	<u>Terminal</u>									
Blue	1									
Black	2									
Green	3									

<i>Step</i>	<i>Description</i>	<i>Diagram</i>
2.	<p>Locate the override switch terminal C218 in the removable dashboard panel.</p> <p>Remove the fork terminal connected to blue wire #3310 from the override switch terminal and replace with the violet wire from the machine input harness.</p> <p>Cut off the fork terminal on the blue wire #3310 and join to the yellow wire from the machine input harness.</p>	
3.	<p>Locate the ground lug near the bulkhead connectors attached to the side of the chassis.</p> <p>Attach the ring lug from the machine input harness to the ground lug.</p> <p>Secure using the supplied M6 bolt.</p>	 <p>View from the from the floor of the cabin towards the middle of the machine</p>
4.	<p>Locate the ignition key switch terminal C210 in the removable dashboard panel.</p> <p>Connect the 6 pin tee connection on the power harness into the C210 connector.</p>	 <p>View behind the dashboard</p>



<i>Step</i>	<i>Description</i>	<i>Diagram</i>
5.	Attach the ring lug from the power harness to the ground lug, located earlier.	 <p data-bbox="858 638 1439 745">View from the from the floor of the cabin towards the middle of the machine</p>



Table 15: Machine Connections

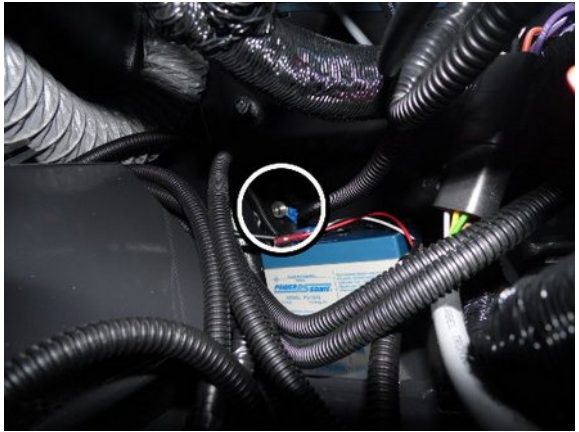

Cabin Loom

The cabin loom connects the CCIM to the machine connections and the other modules of the system.



Do not disconnect the camera power connection while the system is operating as this can damage the fuse.

<i>Step</i>	<i>Description</i>	<i>Diagram</i>
1.	<p>Connect the CCIM and signal light cables to the M12 connectors on the CCIM.</p> <p>Note: It doesn't which of the M12 connectors the CCIM and signal light cables are plugged into.</p>	
2.	<p>Connect the power/camera and IO harnesses to the CCIM bulk head connectors</p>	
3.	<p>Connect the forward and reverse cables to the power/camera harness.</p> <p>Note; The white connector is not used.</p>	

<i>Step</i>	<i>Description</i>	<i>Diagram</i>
4.	<p>Connect the 4 pin connector from the machine input harness into the IO harness.</p> <p>Connect the 6 pin connector from the machine cutout harness to the IO harness.</p> <p>Connect the 12 pin connector from the lock pin release harness to the IO harness.</p> <p>Note: The 2 pin connection on the IO harness is not used.</p>	
5.	<p>Run the 8 pin CCIM cable and the 5 pin user control cable through the gap between the window and the dashboard.</p> <p>Note: The clip-on ferrites will need to be removed to run the cables through the gap between the window and the dashboard. Reattach the ferrites according to Appendix A: Attaching Display Connectors on page 49.</p>	
6.	<p>Run the cables through snake tube.</p> <p>Place cable tie points on the side of the window.</p> <p>Cable tie the snake tube to the cable tie points.</p> <p>Connect into the 8 pin and 5 pin connectors into the display</p>	

<i>Step</i>	<i>Description</i>	<i>Diagram</i>
7.	<p>Connect the spade lug on the black wire to the negative (black) battery terminal on the backup battery.</p> <p>Connect the spade lug on the blue wire to the positive (red) battery terminal on the backup battery.</p>	

Table 16: Cabin Loom Installation





If the M12 screw lock connectors on the display are over tightened it will twist the connector pins attaching the connector to the PCB. See Appendix A: Attaching Display Connectors on page 49 for the correct method of attaching to the display connectors.



If the clip-on ferrites were removed from the CCIM and user control cables. See Appendix B: Reattach Ferrites and page 53 for the correct reattachment position.

Finalisation

This section will complete the final power connections to power the system and finish any additional items.

<i>Step</i>	<i>Description</i>	<i>Diagram</i>
1.	<p>Connect the 3 pin connector from the radio power harness into the power/camera harness.</p> <p>Coil up and store the wire harnesses under the dashboard.</p>	
2.	<p>Attach the backup battery to the velcro on the CCIM and attach the CCIM to the velcro installed earlier to the cabin chassis</p>	 <p>View from the from the floor of the cabin towards the steering column</p>
3.	<p>Reconnect the tee connectors back into the spool assembly and the lock pin release solenoids.</p>	



<i>Step</i>	<i>Description</i>	<i>Diagram</i>
4.	<p>Turn the machine onto first stage/accessories and ensure the system is activated.</p> <p>Adjust the display bracket for optimal viewing</p> <p>Press the top of the Camera switch to activate the forward camera. Adjust the forward camera so the front right wheel is visible.</p> <p>Press the bottom of the Camera switch to activate the reverse camera. Adjust the reverse camera so the video is level.</p>	
5.	<p>Operate the boom movement controls to test if a false N07 fault occurs.</p> <p>If a N07 fault does occur, adjust the arm on the stow switch forwards towards the stow switch trigger.</p> <p>Note: The actual switch arm orientation may differ from the picture.</p>	
6.	<p>Perform a final check on all the cabling and sensors.</p> <p>Replace all the covers</p>	

Table 17: Finalisation

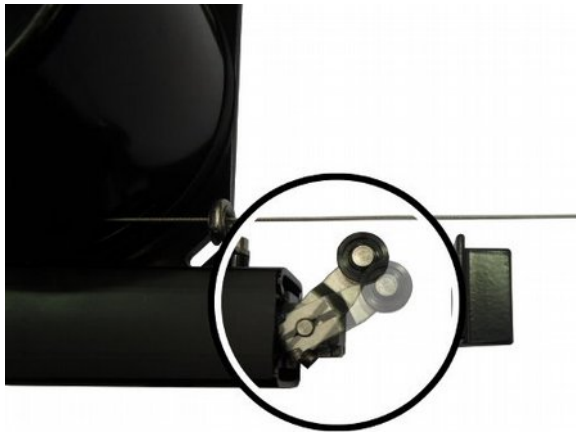

Complete the system checklist once installation has been completed.

Set Time & Sensor Calibration

Once the installation is complete, the time will need to be set and the sensors will require calibration.



A sensor calibration must be performed once the cable reeler and CPIM have been mounted. If the cable reeler or CPIM have been moved/repositioned a recalibration must be performed

<i>Step</i>	<i>Description</i>	<i>Diagram</i>
1.	<p>Press Enter on the user control dial to enter the menu system.</p> <p>Press the arrow buttons to select System Menu.</p> <p>Press Enter to select the menu.</p>	<div style="border: 1px solid black; padding: 5px;"> <p style="margin: 0;">Main Menu</p> <hr/> <p style="margin: 0;">Attachment Selection Menu</p> <div style="background-color: #4a7ebb; color: white; padding: 5px; text-align: center; margin: 5px 0;"> <p style="margin: 0;">System Menu</p> </div> <p style="margin: 0;">Exit Menu</p> <hr/> </div>
2.	Select Advanced Menu	<div style="border: 1px solid black; padding: 5px;"> <p style="margin: 0;">System Menu</p> <hr/> <p style="margin: 0;">Volume / Brightness</p> <hr/> <p style="margin: 0;">Status Menu</p> <hr/> <p style="margin: 0;">Diagnostics Menu</p> <hr/> <p style="margin: 0;">System Tests</p> <div style="background-color: #4a7ebb; color: white; padding: 5px; text-align: center; margin: 5px 0;"> <p style="margin: 0;">Advanced Menu</p> </div> <p style="margin: 0;">Return to Main Menu</p> <hr/> </div>

<i>Step</i>	<i>Description</i>	<i>Diagram</i>														
3.	Enter the password (Default Password: 2-8-4)	<table border="1"> <thead> <tr> <th colspan="2"><i>Enter Password</i></th> </tr> </thead> <tbody> <tr> <td>Number 1</td> <td>2</td> </tr> <tr> <td>Number 2</td> <td>8</td> </tr> <tr> <td>Number 3</td> <td>4</td> </tr> <tr> <td colspan="2">Submit Password</td> </tr> <tr> <td colspan="2">Return to System Menu</td> </tr> </tbody> </table>	<i>Enter Password</i>		Number 1	2	Number 2	8	Number 3	4	Submit Password		Return to System Menu			
<i>Enter Password</i>																
Number 1	2															
Number 2	8															
Number 3	4															
Submit Password																
Return to System Menu																
4.	Select Set Time / Date	<table border="1"> <thead> <tr> <th colspan="2"><i>Advanced Settings</i></th> </tr> </thead> <tbody> <tr> <td colspan="2">Set Time / Date</td> </tr> <tr> <td colspan="2">Sensor Calibrations</td> </tr> <tr> <td colspan="2">Change Language</td> </tr> <tr> <td colspan="2">Change Password</td> </tr> <tr> <td colspan="2">Return to System Menu</td> </tr> </tbody> </table>	<i>Advanced Settings</i>		Set Time / Date		Sensor Calibrations		Change Language		Change Password		Return to System Menu			
<i>Advanced Settings</i>																
Set Time / Date																
Sensor Calibrations																
Change Language																
Change Password																
Return to System Menu																
5.	<p>Enter the correct time and date for your area.</p> <p>Press the arrow keys to select a time/date parameter</p> <p>Press Enter and the parameter will change to red, press the arrow keys to change the value and then press the Enter key to store the value.</p> <p>Note: The hour parameter is in 24 hour clock</p> <p>Repeat for the rest of the time values</p>	<table border="1"> <thead> <tr> <th colspan="2"><i>Set Time / Date</i></th> </tr> </thead> <tbody> <tr> <td>Hour</td> <td>15</td> </tr> <tr> <td>Minute</td> <td>54</td> </tr> <tr> <td>Day</td> <td>10</td> </tr> <tr> <td>Month</td> <td>2</td> </tr> <tr> <td>Year</td> <td>2016</td> </tr> <tr> <td>Region</td> <td>Melbourne</td> </tr> </tbody> </table>	<i>Set Time / Date</i>		Hour	15	Minute	54	Day	10	Month	2	Year	2016	Region	Melbourne
<i>Set Time / Date</i>																
Hour	15															
Minute	54															
Day	10															
Month	2															
Year	2016															
Region	Melbourne															

<i>Step</i>	<i>Description</i>	<i>Diagram</i>
6.	Scroll to the next page and select Save to store the new time/date and return to the Advanced Menu.	<p>The diagram shows a menu with a blue highlighted button labeled "Save" at the top. Below it is a text option labeled "Return to Advanced Menu".</p>
7.	Select Sensor Calibrations	<p>The diagram shows a menu titled "Advanced Settings" at the top. Below the title are five options: "Set Time / Date", "Sensor Calibrations" (highlighted in blue), "Change Language", "Change Password", and "Return to System Menu".</p>
8.	Select Calibrate Carrier Angle and then follow the instructions on the screen to complete the calibration. Repeat for Calibrate Boom Angle and Calibrate Boom Length.	<p>The diagram shows a menu titled "Sensor Calibration Menu" at the top. Below the title are four options: "Calibrate Carrier Angle" (highlighted in blue), "Calibrate Boom Angle", "Calibrate Boom Length", and "Return to Advanced Menu".</p>

Table 18: Sensor Calibration

Schematics

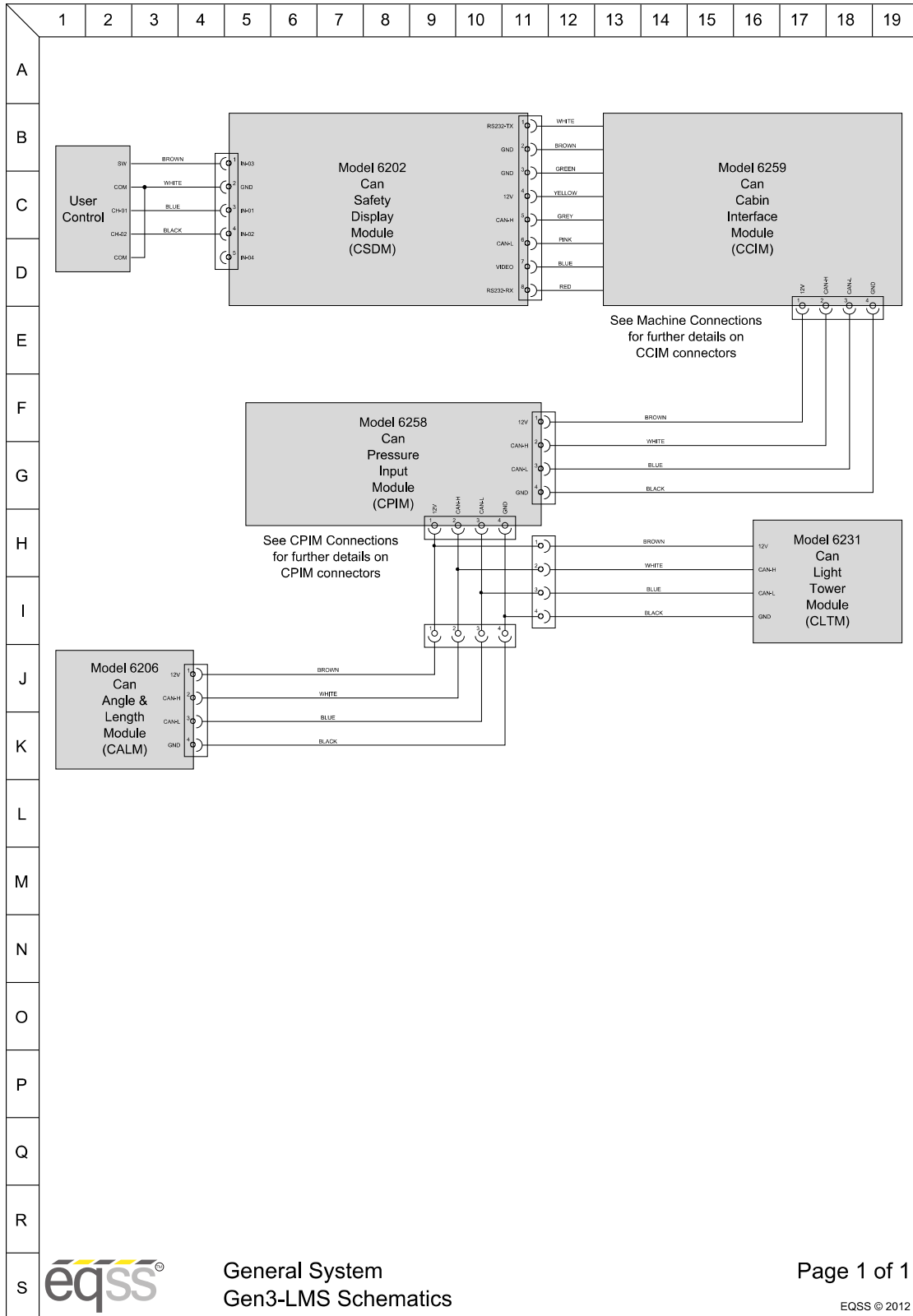

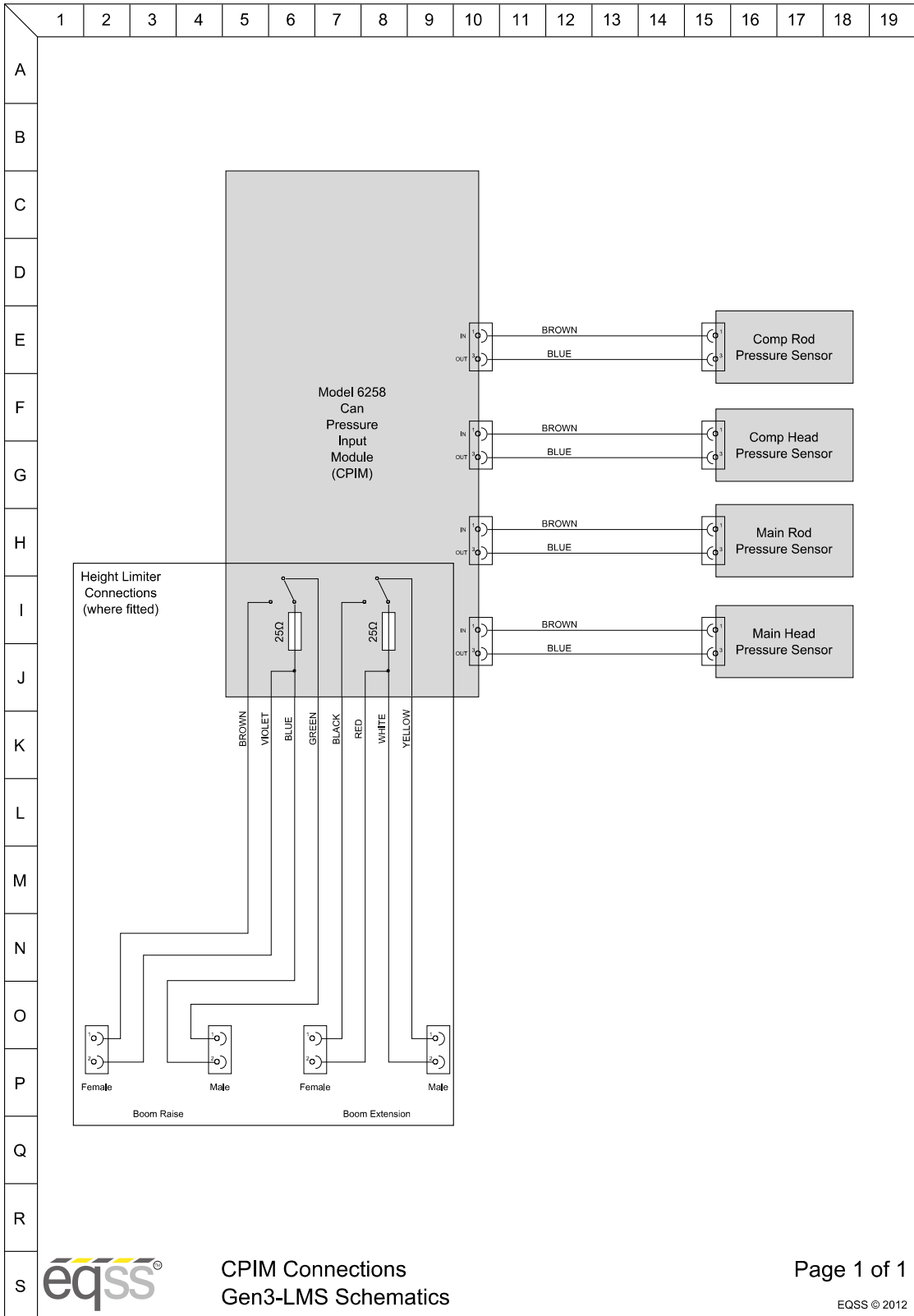

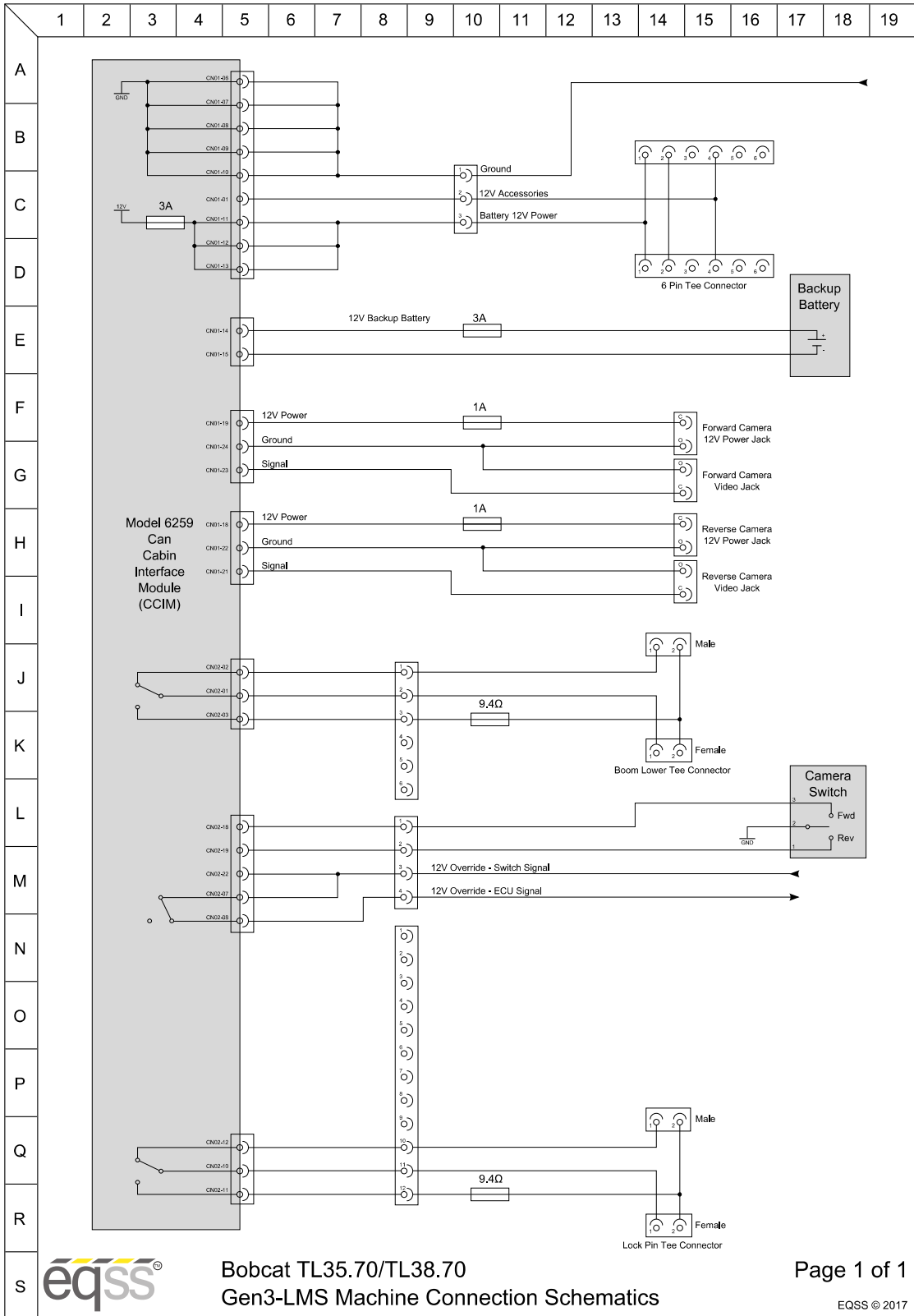

Appendix A: Attaching Display Connectors

The procedure below describes the correct method of attaching the cables to the screw lock connectors on the display.



If the M12 screw lock connectors on the display are over tightened, it will twist the connector pins attaching the connector to the PCB.

<i>Step</i>	<i>Description</i>	<i>Diagram</i>
1.	<p>Connect the cable from the user control to the top 5 pin connector on the display.</p> <p>Connect the cable from the CCIM to the bottom 8 pin connector on the display.</p>	
2.	<p>Line up the alignment hole on the cable connector with the alignment notch on the display connector.</p>	



<i>Step</i>	<i>Description</i>	<i>Diagram</i>
3.	Push the female connector from the cable into the male connector on the display.	
4.	Rotate the nut on the female connector by hand in a clockwise direction, until the tension on the nut starts to increase.	
5.	Push the cable in again and repeat steps 3 and 4 until the connector is secure.	

Table 19: Install Display Connector Procedure



The method to correctly secure the cable is to push-twist-push-twist until the connector is fully inserted and secure. This will minimise the twisting force applied to the connector.

Below is a picture of a damaged connector on the PCB inside the display. This damaged occurred because the connector was over tightened.

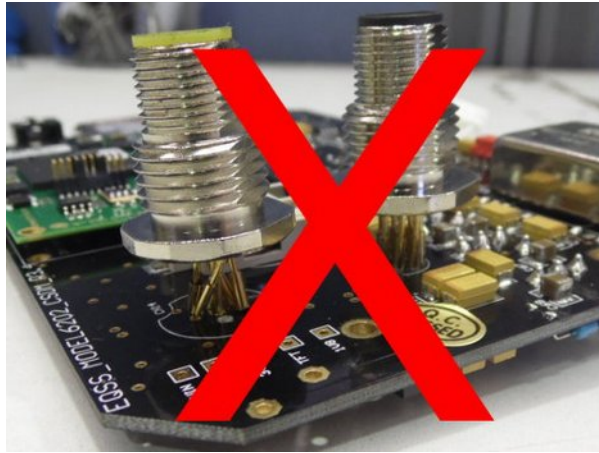

Illustration 4: Damaged Display Connector



Do not use any tools to tighten the connector.



Illustration 5: Do Not Use Tools To Tighten Connector



Do not over-tighten the nuts on the back of the display connectors. These nuts should only be hand tightened. If the nuts are overtightened it will damage the PCB inside the display.



Illustration 6: Do Not Over Tighten Nuts



Damage to the display connectors is not covered under warranty.

Appendix B: Reattach Ferrites

If the clip-on ferrites on the displays are removed during installation, they will need to be reattached as shown in the procedure below.

 If the ferrites are not reinstalled or attached in the specified location the Gen3-LMS kit will not meet the AS/NZS CISPR 22:2006 certification.

<i>Step</i>	<i>Description</i>	<i>Diagram</i>
1.	<p>Attach the two clip-on ferrites at a location of 60 mm and 260 mm from the start of the connector to the start of the ferrite.</p> <p>Do this for both the CCIM and user control cables that plug into the display.</p>	

Table 20: Reattach Ferrites Procedure

Indexes and Tables

Illustration Index

Illustration 1: Machine Boom.....	7
Illustration 2: Machine Chassis.....	8
Illustration 3: Cable Reeler Mounting Position.....	13
Illustration 4: Damaged Display Connector.....	51
Illustration 5: Do Not Use Tools To Tighten Connector.....	51
Illustration 6: Do Not Over Tighten Nuts.....	52

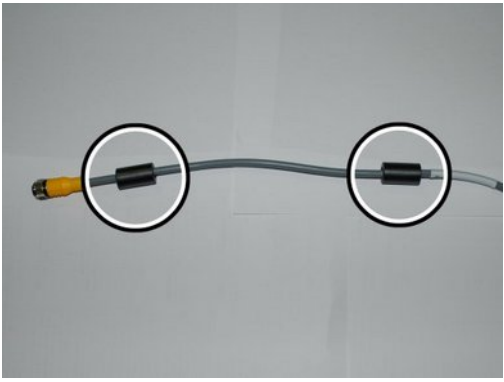
Index of Tables

Table 1: Component Installation Index.....	6
Table 2: Cable Installation Index.....	6
Table 3: Cover removal.....	10
Table 4: Cable Reeler Installation.....	12
Table 5: Pressure Sensor Installation.....	16
Table 6: Compensation Pressure Sensor Installation.....	17
Table 7: Reverse Camera Installation.....	18
Table 8: Can Pressure Input Module (CPIM) Installation.....	21
Table 9: Signal Light Installation.....	24
Table 10: Forward Camera Installation.....	25
Table 11: External Cable Completion.....	30
Table 12: Display Installation.....	31
Table 13: User Input Control Installation.....	32
Table 14: CCIM Installation.....	33
Table 15: Machine Connections.....	36
Table 16: Cabin Loom Installation.....	39
Table 17: Finalisation.....	41
Table 18: Sensor Calibration.....	45
Table 19: Install Display Connector Procedure.....	50
Table 20: Reattach Ferrites Procedure.....	53

Equipment Safety Systems Pty. Ltd. ABN: 31 061 789 151
27 Cumberland Drive, Seaford 3198, Victoria, Australia

Tel: +61 3 8770 6555
Fax: +61 3 8770 6590
Web: www.eqss.com.au