



eqss™ Gen-3 LMS Telehandler Load Management System

Installation Manual for MTX1030 or Non EN15000 Manual Tool Recognition

Failure To Follow Installation Manual Will Void Warranty

Documentation Conventions

The list below highlights important documentation conventions.



Text presented in this manner is intended to provide the user with some general information. The user should ensure information presented in this manner is clearly understood.



Text presented in this manner provides the user with information to assist in completion of the current procedure being explained.



Text presented in this manner indicates that a failure to follow directions could result in damage to equipment, loss of information, bodily harm, or loss of life.

Important Information

Information contained in this publication regarding this device's applications and the like is provided only for your convenience and may be superseded by updates. It is your responsibility to ensure that the application or our equipment meets with your specifications.

EQUIPMENT SAFETY SYSTEMS MAKE NO REPRESENTATIONS OR WARRANTIES OF ANY KIND WHETHER EXPRESS OR IMPLIED, WRITTEN OR ORAL, STATUTORY OR OTHERWISE, RELATED TO THE INFORMATION, INCLUDING BUT NOT LIMITED TO ITS CONDITION, QUALITY, PERFORMANCE, MERCHANTABILITY OR FITNESS FOR PURPOSE.

Equipment Safety Systems disclaims all liability arising from this information and its use. Use of Equipment Safety Systems' products as critical components in life support systems is not authorised except with express written approval by Equipment Safety Systems. No licenses are conveyed, implicitly or otherwise, under any Equipment Safety Systems intellectual property rights.

Table of Contents

Tools Required for Installation.....	6
Installation Index.....	7
Covers.....	11
Cable Reeler Installation.....	13
Cable Reeler Mounting Position.....	15
Pressure Sensor Installation.....	16
Pressure Manifold.....	16
Compensation Pressure Sensors.....	18
Reverse Camera.....	19
Machine Input Harness.....	21
Forward Camera.....	22
Stabiliser Cable Harness.....	24
Light Tower Installation.....	26
Light Tower Bracket Mounting Position.....	27
Can Pressure Input Module (CPIM).....	28
External Cable Completion.....	29
Display Installation.....	31
User Input Control.....	32
Can Cabin Interface Module (CCIM).....	33
Cabin Loom.....	34
Finalisation.....	37
Sensor Calibration.....	40
Schematics.....	43

Indexes and Tables.....46

Tools Required for Installation

The tools required to perform the installation of the TSS are listed below

- Pencil or Texta
- Drill
- Drill bits
 - 3.3 mm
 - 4.5 mm
 - 5 mm
 - 6.25 mm
 - 6.8 mm
 - 8.5 mm
- Centre punch
- Tap T-Handle
- Taps
 - M6
 - M7 x 0.75
 - M8
- Drill and tap oil
- Metric Allen keys
- Phillips Head screw driver
- Spanners and sockets
 - 7 mm
 - 10 mm
 - 13 mm
- Loctite thread locker
- Side cutters
- Stanley knife
- Crimpers
- Wire strippers

Installation Index

The components and cables of the Gen-3 Telehandler Load Management System are outline in the tables below. The following pages show where the components are installed and the cable routing.

See the appropriate manual section for a detailed installation description for each component.



Refer to this section for any component placement or cable routing issues

<i>Item</i>	<i>Component Description</i>
1	Cable Reeler
2	Main Lift Cylinder Pressure Sensors
3	Compensation Cylinder Pressure Sensors
4	Can Pressure Input Module (CPIM)
5	Forward Camera
6	Light Tower
7	Rear Camera
8	Can Cabin Interface Module (CCIM)
9	Display Module
10	LMI Module
11	Stabiliser Connections
12	Joystick Connections (X43)

Table 1: Component Installation Index

<i>Colour</i>	<i>Cable Description</i>
Yellow	Boom Cable
Dark Green	Main Cylinder Pressure Sensor Cables
Dark Blue	Compensation Cylinder Pressure Sensors Cables
Light Blue	Forward Camera Cable
Violet	Light Tower Cable
Aqua	Rear Camera Cable
Dark Purple	CCIM Cable
Light Green	LMI Cable Harness
Red	Display Cable
Orange	User Input Control Cable
Brown	Machine Input Harness
Dark Yellow	Stabiliser Harness

Table 2: Cable Installation Index



Illustration 1: Machine Boom

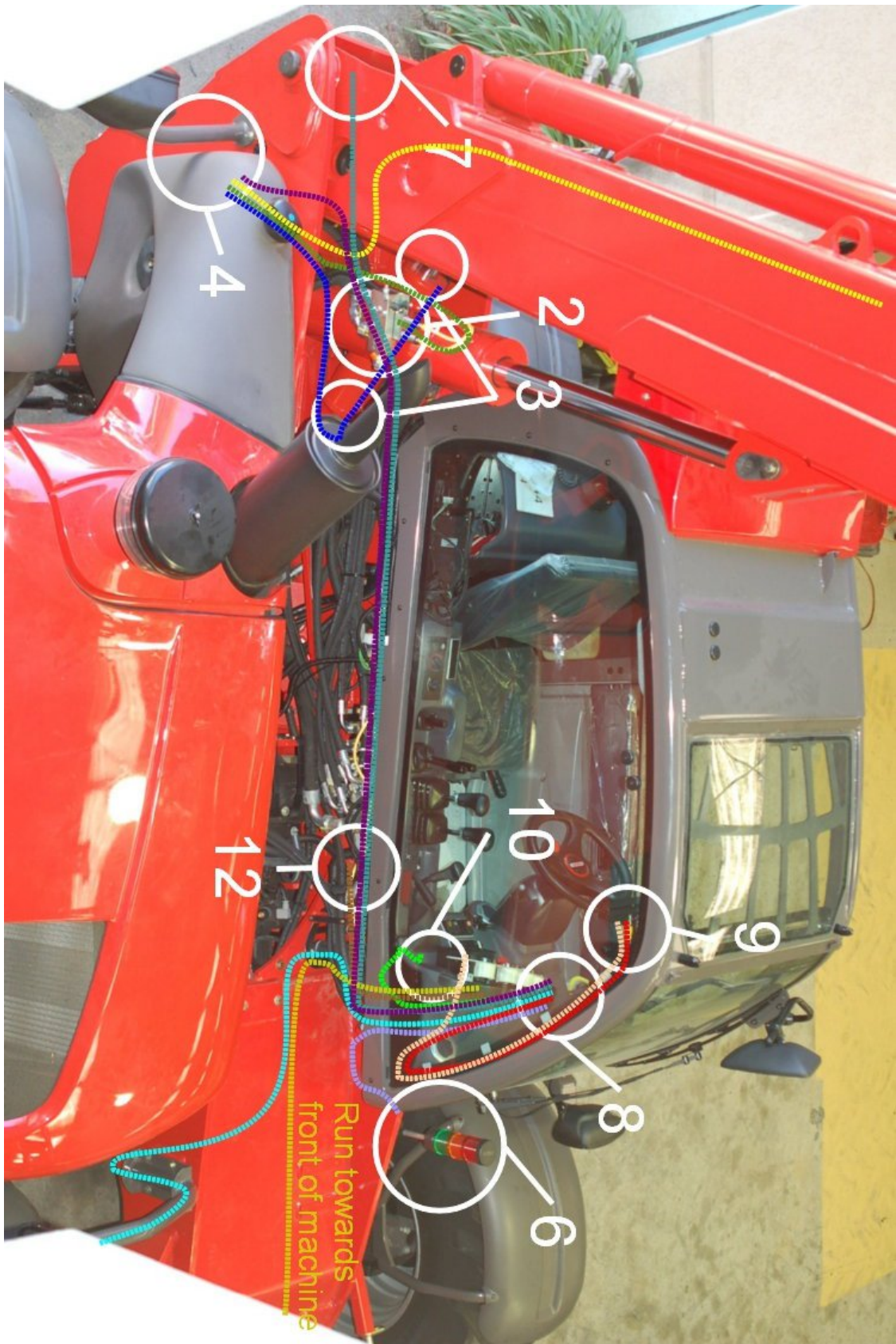





Illustration 2: Machine Chassis

Covers

Remove the following covers before starting the installation

<i>Step</i>	<i>Description</i>	<i>Diagram</i>
1.	Remove the top and lower rear cover behind the boom.	
2.	Remove the side panel next to the cabin under the boom.	
3.	Remove the covers under the boom. Remove the covers over the stabiliser pressure manifolds	



<i>Step</i>	<i>Description</i>	<i>Diagram</i>
4.	Inside the cabin remove the dashboard.	
5.	Remove the cover over the fluid containers	

Table 3: Cover removal

Cable Reeler Installation

The cable reeler is used to measure the boom extension to determine the maximum lifting capacity.

<i>Step</i>	<i>Description</i>	<i>Diagram</i>
1.	<p>Drill and tap the holes for the cable reeler according to the mounting diagram on page 15.</p> <p>Mount using the supplied M6 x 16 mm bolts and washers.</p>	
2.	<p>Drill and tap an M8 hole for the cable anchor. Ensure the cable anchor is positioned so the cable runs in line with the boom.</p> <p>Mount the cable anchor and attach the cable.</p>	
3.	<p>Drill and tap the M6 holes for the stow switch trigger bracket.</p> <p>Mount the stow switch trigger bracket using the supplied M6 x 12 mm bolts and washers.</p> <p>Adjust the length of the trigger plate to ensure the stow switch is pressed when the boom is retracted.</p>	

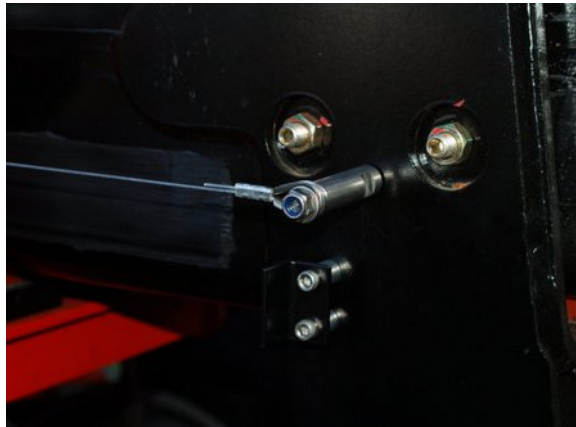
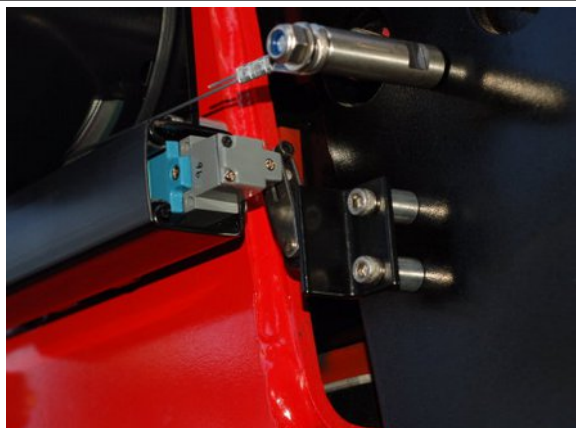

<i>Step</i>	<i>Description</i>	<i>Diagram</i>
4.	Connect the supplied M12 10 metre cable (CB001027) into the cable reeler connection.	
5.	<p>Run the cable along the hydraulic pipes running down the boom, secure using cable ties every 150 mm to 200 mm.</p> <p>Cable tie to the flexible hydraulic hoses down to the chassis. Make sure the cable isn't pinched or stretched when the boom is raised or lowered.</p> <p>Run the remainder of the cable out the hole below the lift cylinder towards the rear of the machine and cable tie with the other cables during External Cable Completion on page 29.</p>	

Table 4: Cable Reeler Installation



For further details on running the boom cable refer to the Installation Index on page 7

Cable Reeler Mounting Position

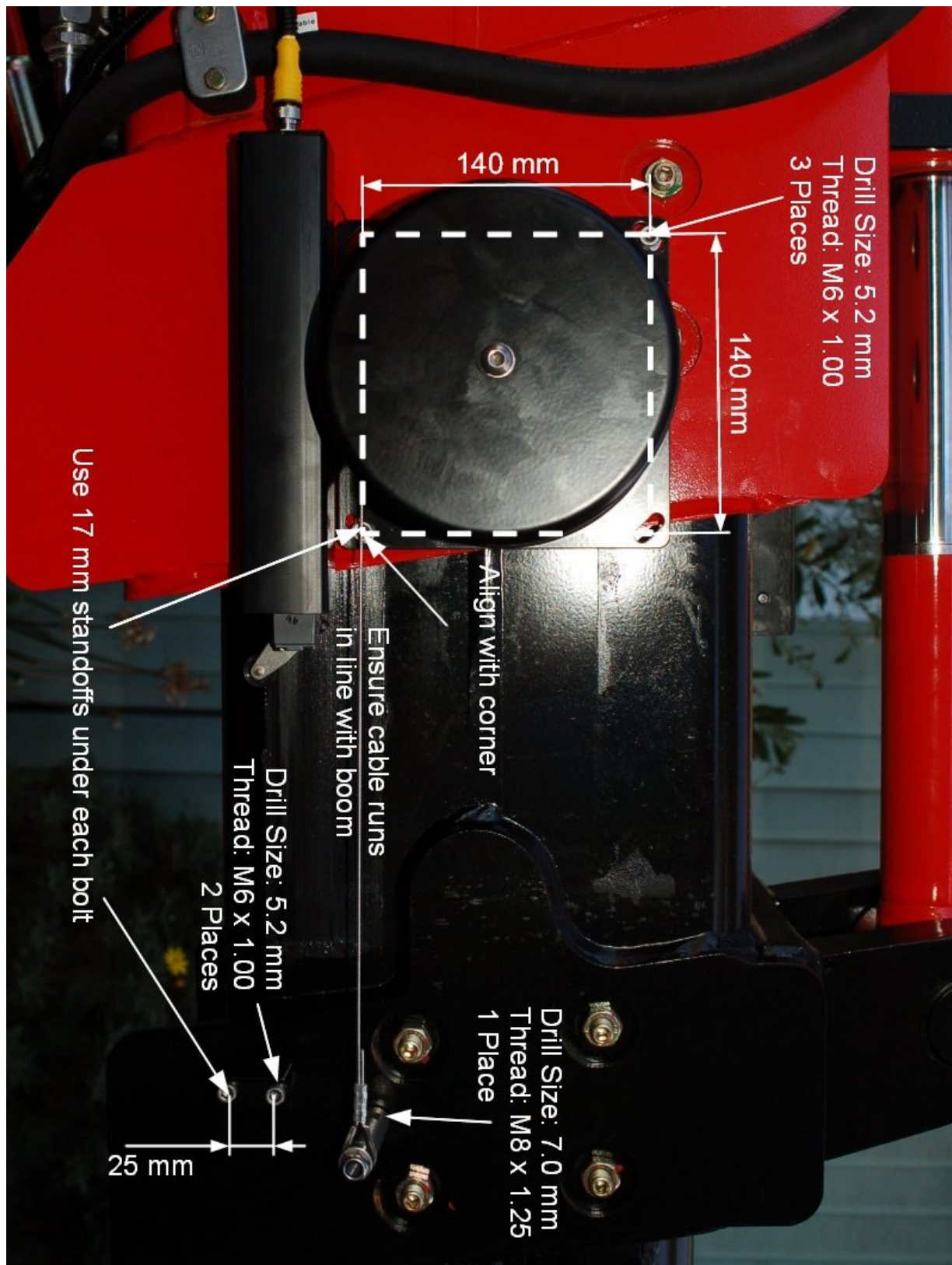



Illustration 3: Cable Reeler Mounting Position

Pressure Sensor Installation

The hydraulic pressure sensors are used to measure the lifting load of the telehandler.

Pressure Manifold

<i>Step</i>	<i>Description</i>	<i>Diagram</i>
1.	<p>Raise the boom to approximately 40 degrees.</p> <p>Support and secure the boom using an A Frame or similar apparatus. It must support at least 2 tons.</p> <p>Apply the handbrake and insert chock under wheels.</p> <p>Remove the counterbalance valve on the side of the hydraulic lifting ram.</p> <p>Removing the counterbalance valve will release the hydraulic pressure which may result in a spray of oil.</p> <p>Secure the pressure manifold using the supplied 70 mm bolts and seals.</p> <p>Start the machine, pressurise the boom and check for leaks.</p>	



<i>Step</i>	<i>Description</i>	<i>Diagram</i>
2.	<p>Connect the supplied M12 4 metre cables (CB001026) into each of the pressure sensors.</p> <p>Add both cables to 3 m of snake tube. Cable tie to the flexible hydraulic hoses connected to the main lift cylinder. Make sure the cable isn't pinched or stretched when the boom is raised or lowered.</p> <p>Run the remainder of the cable out the hole above the rear axle under the lift cylinder towards the rear of the machine and cable tie with the other cables during External Cable Completion on page 29.</p>	

Table 5: Pressure Manifold Installation



For further details on running the pressure sensor cables refer to the Installation Index on page 7

Compensation Pressure Sensors

Step	Description	Diagram
1.	<p>Install the pressure sensors with the tee connections into the head and rod of the compensation cylinder.</p> <p>Start the machine, pressurise the boom and check for leaks.</p> <p>Connect the supplied M12 4 metre cables (CB001026) into each of the pressure sensors.</p> <p>Add both cables to 3 m of snake tube.</p> <p>Run the remainder of the cable out the hole above the rear axle under the lift cylinder towards the rear of the machine and cable tie with the other cables during External Cable Completion on page 29.</p>	 <p>View from behind the cabin towards the rear of the machine</p>

Table 6: Compensation Pressure Sensor Installation



For further details on running the pressure sensor cables refer to the Installation Index on page 7

Reverse Camera

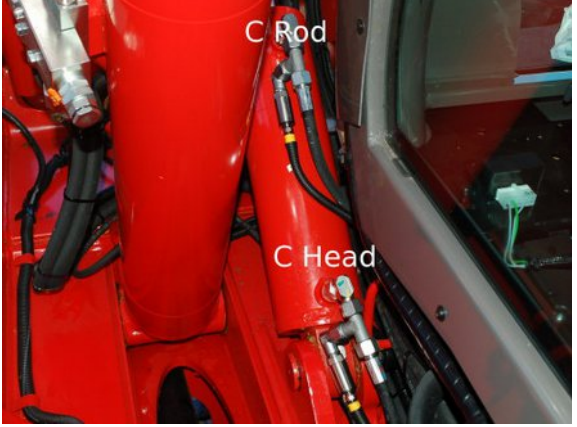
The rear camera video is displayed on the screen when the machine is in reverse gear to allow the operator to see behind the telehandler while reversing.



Step	Description	Diagram
1.	<p>Drill a 31mm hole in the location shown.</p> <p>Insert the camera through the hole and adjust the angle using the alignment washers.</p>	
2.	<p>Connect the camera power and signal connectors to the supplied 5m camera cable (CB001032).</p> <p>Note; The white connector is not used.</p> <p>Secure the camera cable using a single cable tie to maintain the connector location.</p> <p>Run the remainder of the cable towards the cabin and cable tie with the other cables during External Cable Completion on page 29.</p>	

Table 7: Reverse Camera Installation



The camera's viewing angle may need to be adjusted once the system is installed and the display is operational.



Once the cable has secured with a cable tie disconnect the cable to remove the rear cover until the installation is finalised



For further details on running the camera cable refer to the Installation Index on page 7

Machine Input Harness



Isolate the main battery before connecting into the machine wiring

Step	Description	Diagram
1.	<p>Locate the connectors under the boom next to the cabin, that connect into the joystick.</p> <p><u>Mechanical joystick</u> Connect the 6 pin tee connector into X43.</p> <p><u>Electronic joystick</u> Connect the 12 pin tee connector into X67.</p> <p>Run the cable towards the cabin and cable tie with the other cables during External Cable Completion on page 29.</p>	

Table 8: Joystick Cable Harness Installation



For further details on running the machine input harness refer to the Installation Index on page 7

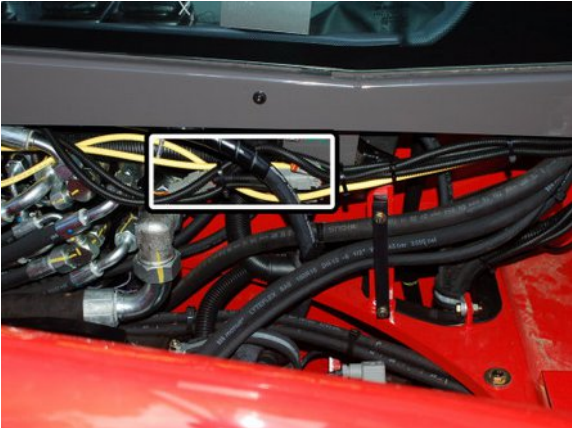

The other wires on the machine input harness for the override switch will be installed in the section Finalisation on page 37.

Forward Camera

The forward camera video is displayed on the screen when the machine is in forward gear to allow the operator to see past the boom to obstructions that would damage the right front tyre.



<i>Step</i>	<i>Description</i>	<i>Diagram</i>
1.	<p>Mount the camera to the side mirror using the p-clips as shown.</p> <p>Secure using two M6 nuts.</p>	
2.	<p>Connect the camera power and signal connectors to the supplied 5m camera cable (CB001032).</p> <p>Note; The white connector is not used.</p> <p>Run the cable along the same path as the headlight cable, run it through the headlight post, then under the chassis to the side of the cabin. Cable tie to the headlight cable every 150 mm to 200 mm.</p> <p>Complete the cable installation during External Cable Completion on page 29.</p>	

Table 9: Forward Camera Installation



The camera's viewing angle may need to be adjusted once the system is installed and the display is operational.



For further details on running the camera cable refer to the Installation Index on page 7

Stabiliser Cable Harness

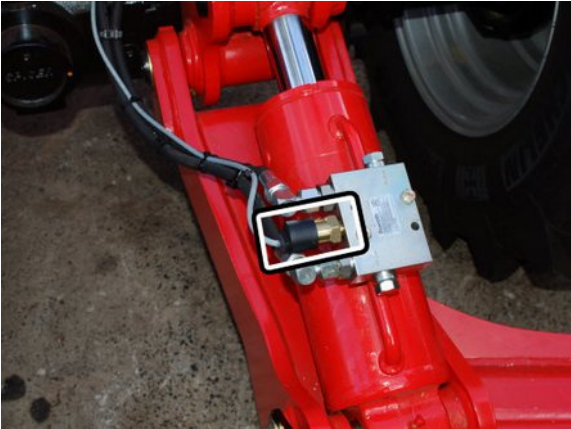
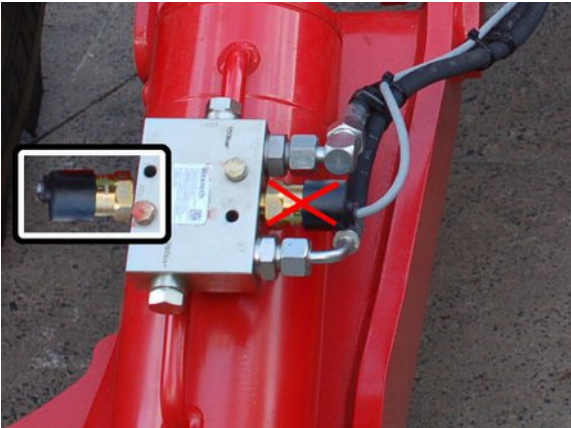

The pressure switches don't come with the MT1030 as standard and will need to be order from Manitou.

<i>Step</i>	<i>Description</i>	<i>Diagram</i>
1.	Remove the blanking plug from the pressure manifold and install the pressure switch, into the left stabiliser	
2.	<p>The pressure port for the right stabiliser manifold block may not be connected to the head of the cylinder.</p> <p>If this is the case the manifold will need to be removed and a thread drilled into the other side of the manifold connecting to the head of the cylinder.</p> <p>The cover will also need to be modified to protect the pressure switch.</p>	



<i>Step</i>	<i>Description</i>	<i>Diagram</i>
3.	<p>Connect the 3 pin connector labelled left stabiliser from the stabiliser harness into the left stabiliser pressure switch.</p> <p>Connect the 3 pin connector labelled right stabiliser from the stabiliser harness into the right stabiliser pressure switch.</p> <p>Cable tie to the existing snake tube.</p> <p>Run the remainder of the cable towards the cabin and cable tie with the front camera cable harness during External Cable Completion on page 29.</p>	

Table 10: Stabiliser Cable Harness Installation

	<p>For further details on running the stabiliser cable harness refer to the Installation Index on page 7</p>
---	--

Light Tower Installation

The light tower warns other workers when the telehandler is lifting loads close to its maximum capacity.

<i>Step</i>	<i>Description</i>	<i>Diagram</i>
1.	<p>Drill and tap the holes required to mount the light tower bracket on the chassis according to the mounting diagram on page 27.</p> <p>Secure using the supplied bolts as described on page 27.</p> <p>Run the cable through the gap between the chassis and the cabin towards the side of the cabin.</p> <p>Complete the cable installation during External Cable Completion on page 29.</p>	

Table 11: Light Tower Installation



For further details on running the light tower cable refer to the Installation Index on page 7

Light Tower Bracket Mounting Position

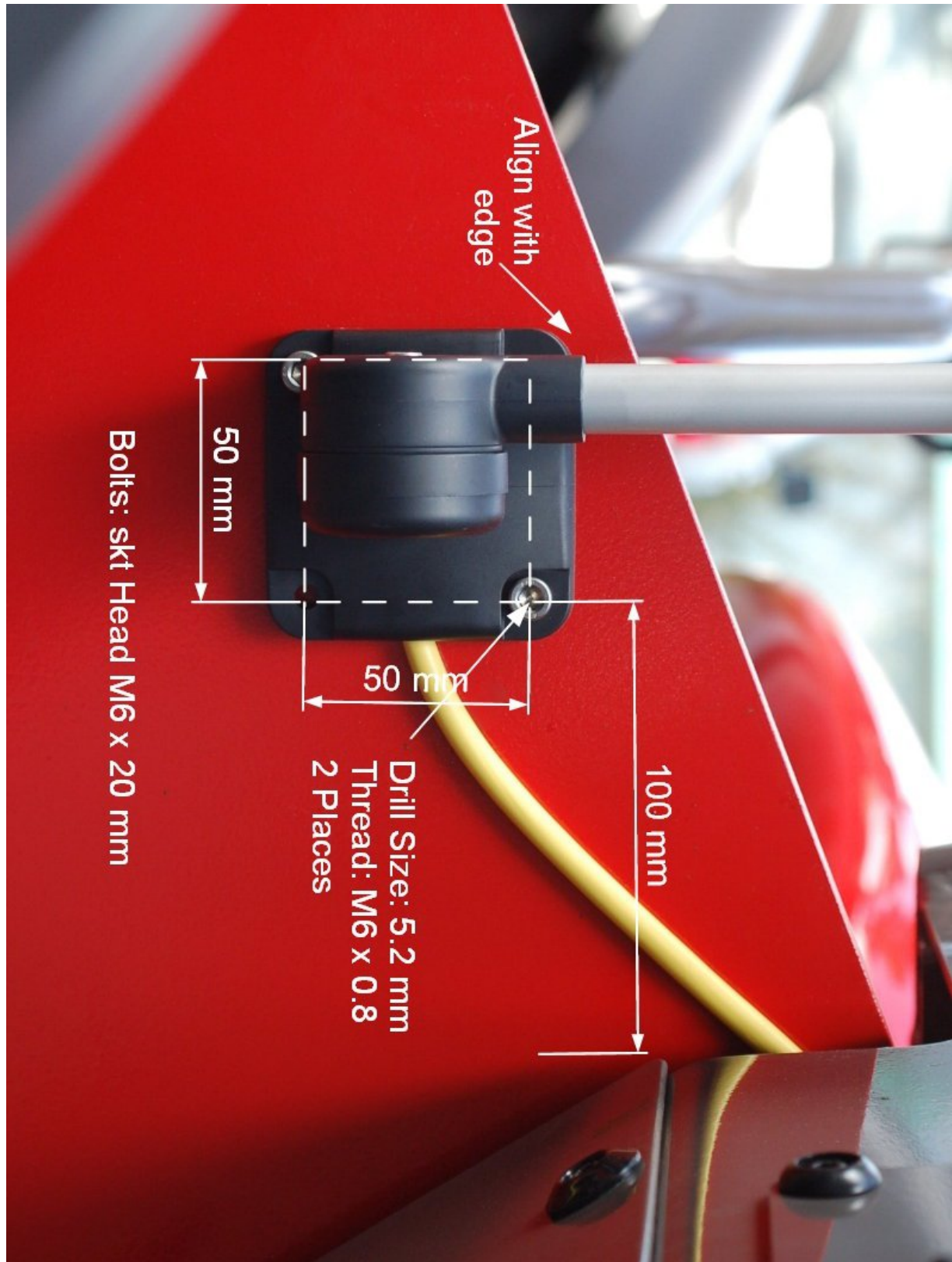

Illustration 4: Light Tower Bracket Mounting Position

Can Pressure Input Module (CPIM)

The CPIM is responsible for processing the information sent from the pressure sensors.



Accidentally swapping the pressure sensor connections will not damage system and can be determined if the display is showing a negative load.



Do not plug the pressure sensor cable into the far right side boom cable. This will damage the system.





<i>Step</i>	<i>Description</i>	<i>Diagram</i>
1.	<p>Drill and tap two M8 holes for the CPIM bracket in the chassis rear panel.</p> <p>Mount using the supplied M8 x 12mm bolts and washers.</p>	
2.	<p>Connect the cables for the pressure sensors and boom cable to the CPIM according to the picture shown.</p> <p>Note: The CCIM cable will be installed during External Cable Completion on page 29.</p>	

Table 12: Can Pressure Input Module (CPIM) Installation

External Cable Completion

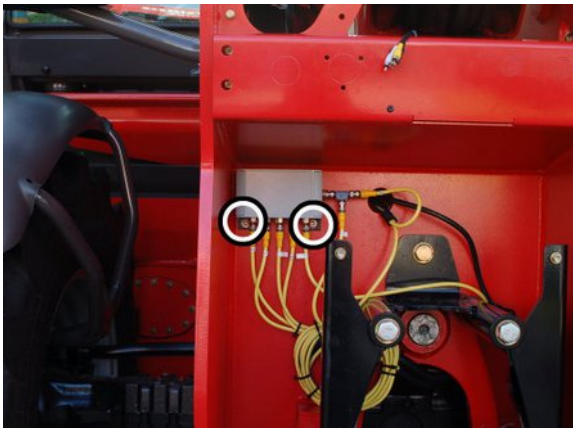
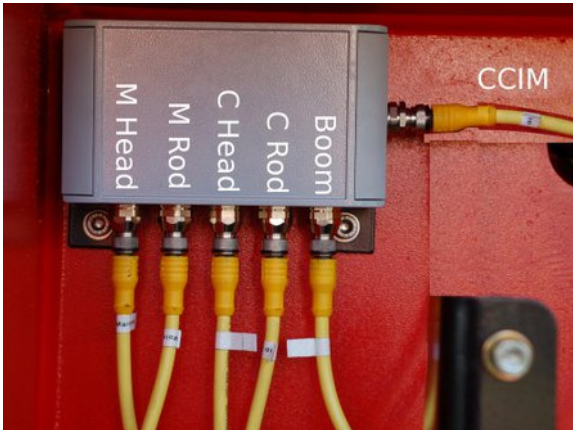
All external cabling is completed in this step.

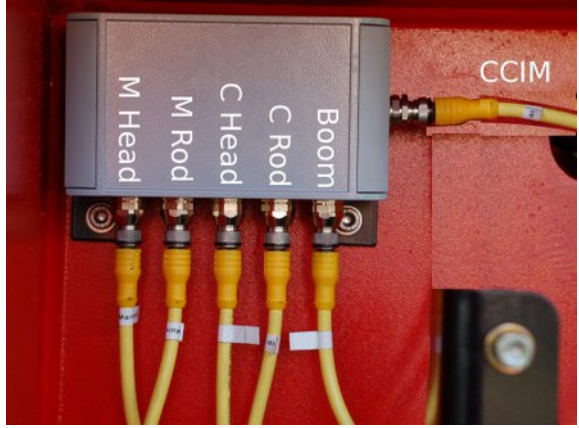
<i>Step</i>	<i>Description</i>	<i>Diagram</i>
1.	Coil up and cable tie the additional cabling for the pressure sensors and boom cables and store underneath the CPIM.	
2.	<p>Connect the supplied M12 4 metre cable (CB001026) into the connection out of the right side of the CPIM for the CCIM cable.</p> <p>Run the cable out the hole under the lift cylinder.</p>	
3.	Cable tie the CCIM, rear camera and machine input harnesses together along the side to the front of the cabin.	

<i>Step</i>	<i>Description</i>	<i>Diagram</i>
4.	<p>Run the CCIM, light tower, machine input harness, stabiliser cable harness and camera cables up through the hole into the cabin under the dashboard.</p> <p>Note: Pull the entire length of cable through into the cabin, excess cable will be stored under the dashboard cover in the cabin.</p>	

Table 13: External Cable Completion



For further details on running the cables refer to the Installation Index on page 7

Display Installation

The display shows the current safety status of the telehandler.

<i>Step</i>	<i>Description</i>	<i>Diagram</i>
1.	<p>Attach the display bracket to the level indicator in the top right corner using the supplied M6 x 35 mm bolts and nuts.</p> <p>Attach the display to the bracket and tighten the grub screw</p>	

Table 14: Display Installation



Adjust the display bracket for optimal viewing angle once the display is powered

User Input Control

The user input control consists of a single switch mounted in the dashboard.

<i>Step</i>	<i>Description</i>	<i>Diagram</i>
1.	Drill a 34 mm hole into the dashboard. Install the user input control dial in the dashboard, aligned so the Enter cap is facing up.	

Table 15: User Input Control Installation

Can Cabin Interface Module (CCIM)

The CCIM connects the system into the machine electronics.



<i>Step</i>	<i>Description</i>	<i>Diagram</i>
1.	Position the backup battery underneath the dashboard as shown and secure using double sided velcro tape.	
2.	<p>Position the CCIM next to the brake fluid container as shown and secure using double sided velcro tape.</p> <p>Remove the CCIM from the velcro to allow the connections to be completed. Reattach to the velcro in the section Finalisation on page 37.</p>	



Table 16: CCIM Installation



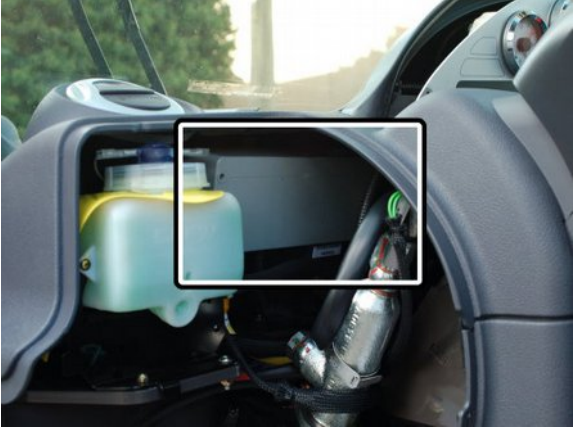

Cabin Loom

The cabin loom connects the CCIM to the machine connections and the other modules of the system.

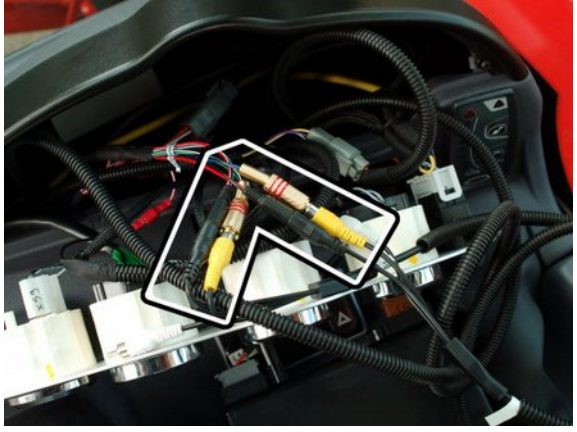

Isolate the main battery before connecting into the machine wiring

<i>Step</i>	<i>Description</i>	<i>Diagram</i>
1.	<p>Connect the CCIM and light tower cables to the M12 connectors on the CCIM.</p> <p>Note: It doesn't which which of the M12 connectors the CCIM and light tower cables are plugged into.</p>	 <p>The image shows a grey CCIM (Control and Camera Interface Module) unit. It has a 'Display' port on the left, and three M12 connectors on the bottom labeled 'Camera / Power', 'I/O', and 'CAN'. Two cables are plugged into the 'I/O' and 'CAN' ports.</p>
2.	<p>Connect the cabin loom to the CCIM bulk head connectors</p>	 <p>The image shows a close-up of a connector on the cabin loom. A white label on the connector reads 'POWER CAMERA HARNESS'. The connector is plugged into a port on the CCIM bulk head.</p>

<i>Step</i>	<i>Description</i>	<i>Diagram</i>
3.	<p>Connect the camera power and signal cables to the cabin loom.</p> <p>Note: The white connector is not used.</p>	
4.	<p>Connect the 3 pin tee connectors from the cutout harness into the 3 pin connector from the LMI.</p> <p>Note: Once the cutout harness is installed the machine will be in cutout until the installation is complete.</p>	
5.	<p>Connect the 4 pin female connector from the machine input harness, the 6 pin female connector from the spu cable harness and the 2 pin and 12 pin connectors from the stabiliser harness to the cabin loom connectors.</p>	
6.	<p>Run the 8 pin cable from the CCIM and 5 pin cable from the user control through the gap between the window and the dashboard.</p> <p>Run both cables through snake tube and attach to the connectors to the back of the display.</p>	







<i>Step</i>	<i>Description</i>	<i>Diagram</i>
7.	<p>Place cable tie points on the side of the window.</p> <p>Cable tie the snake tube to the cable tie points.</p>	

Table 17: Cabin Loom Installation

Finalisation

This section will complete the final power connections to power the system and finish any additional items.

<i>Step</i>	<i>Description</i>	<i>Diagram</i>
1.	<p>Cut wire 478 into terminal 1 of the switch.</p> <p>Join the yellow wire from the machine input harness to side of wire 478 leading towards the switch.</p> <p>Join the violet wire from the machine input harness to the other side of wire 478 leading towards the electronics.</p>	
2.	<p>Locate the power connector for the radio.</p> <p>Connect the radio power tee connectors from the radio power harness to the power connector for the radio.</p> <p>Connect the 3 pin connector to the cabin loom connector.</p>	
3.	<p>Connect the spade lug on the black wire to the negative (black) battery terminal.</p> <p>Connect the spade lug on the blue wire to the positive (red) battery terminal.</p>	

<i>Step</i>	<i>Description</i>	<i>Diagram</i>
4.	Attach the CCIM to the velcro strips installed earlier.	
5.	<p>Coil up the extra cables and store underneath the dashboard cover.</p> <p>Reconnect the main battery from the isolation switch.</p> <p>Turn the machine onto first stage /accessories and ensure the system is activated.</p>	
6.	<p>Adjust the display bracket for optimal viewing</p> <p>Set the machine into forward gear to activate the forward camera. Adjust the forward camera so the front right wheel is visible.</p> <p>Set the machine into reverse gear to activate the reverse camera. Adjust the reverse camera so the video is level.</p>	

<i>Step</i>	<i>Description</i>	<i>Diagram</i>
7.	Perform a final check on all the cabling and sensors. Replace all the covers	

Table 18: Finalisation



Complete the system checklist once installation has been completed.

Time/Date and Sensor Calibration

Once the installation is complete, the time/date will need to be set and the sensors will require calibration.



A sensor calibration must be performed once the cable reeler and CPIM have been mounted. If the cable reeler or CPIM have been moved/repositioned a recalibration must be performed

<i>Step</i>	<i>Description</i>	<i>Diagram</i>
1.	<p>Press Enter on the user control dial to enter the menu system.</p> <p>Press the up or down buttons on the user control dial to select System Menu.</p> <p>Press Enter on the user control dial to enter the menu.</p>	<p>Main Menu</p> <hr/> <p>Attachment Selection Menu</p> <hr/> <p>System Menu</p> <hr/> <p>Exit Menu</p> <hr/>
2.	Select Advanced Menu	<p>System Menu</p> <hr/> <p>Volume / Brightness</p> <hr/> <p>Status Menu</p> <hr/> <p>Diagnostics Menu</p> <hr/> <p>System Tests</p> <hr/> <p>Advanced Menu</p> <hr/> <p>Return to Main Menu</p> <hr/>

<i>Step</i>	<i>Description</i>	<i>Diagram</i>										
3.	Enter the password (Default Password: 2-8-4)	<p style="text-align: center;">Enter Password</p> <hr/> <table style="width: 100%; border-collapse: collapse;"> <tr> <td style="width: 60%; text-align: center;">Number 1</td> <td style="width: 40%; text-align: center;">2</td> </tr> <tr> <td style="border-top: 1px solid black;">Number 2</td> <td style="border-top: 1px solid black; text-align: center;">8</td> </tr> <tr> <td style="border-top: 1px solid black;">Number 3</td> <td style="border-top: 1px solid black; text-align: center;">4</td> </tr> <tr> <td colspan="2" style="text-align: center; background-color: #0000FF; color: white;">Submit Password</td> </tr> <tr> <td colspan="2" style="text-align: center;">Return to System Menu</td> </tr> </table>	Number 1	2	Number 2	8	Number 3	4	Submit Password		Return to System Menu	
Number 1	2											
Number 2	8											
Number 3	4											
Submit Password												
Return to System Menu												
4.	Select Set Time / Date	<p style="text-align: center;">Advanced Settings</p> <p style="text-align: center; background-color: #0000FF; color: white;">Set Time / Date</p> <hr/> <p style="text-align: center;">Sensor Calibrations</p> <hr/> <p style="text-align: center;">Change Language</p> <hr/> <p style="text-align: center;">Return to System Menu</p>										
5.	Enter the current time and date. Note: The time is in 24 hour clock. Select the region that matches the time zone for the machine's destination. Select Save (on the second page) when complete.	<p style="text-align: center;">Set Time / Date</p> <p style="text-align: center; background-color: #0000FF; color: white;">Hour 19</p> <hr/> <p style="text-align: center;">Minute 28</p> <hr/> <p style="text-align: center;">Day 8</p> <hr/> <p style="text-align: center;">Month 8</p> <hr/> <p style="text-align: center;">Year 2014</p> <hr/> <p style="text-align: center;">Region Melbourne</p> <hr/> <p style="text-align: center;">▼</p>										
6.	Select Sensor Calibrations	<p style="text-align: center;">Advanced Settings</p> <p style="text-align: center;">Set Time / Date</p> <p style="text-align: center; background-color: #0000FF; color: white;">Sensor Calibrations</p> <hr/> <p style="text-align: center;">Change Language</p> <hr/> <p style="text-align: center;">Change Password</p> <hr/> <p style="text-align: center;">Return to System Menu</p>										

<i>Step</i>	<i>Description</i>	<i>Diagram</i>
7.	Select Calibrate Carrier Angle and then follow the instructions on the screen to complete the calibration. Repeat for Calibrate Boom Angle and Calibrate Boom Length.	<p>The diagram shows a menu titled "Sensor Calibration Menu" with four options: "Calibrate Carrier Angle", "Calibrate Boom Angle", "Calibrate Boom Length", and "Return to Advanced Menu". The "Calibrate Carrier Angle" option is highlighted in blue.</p>

Table 19: Sensor Calibration

Schematics

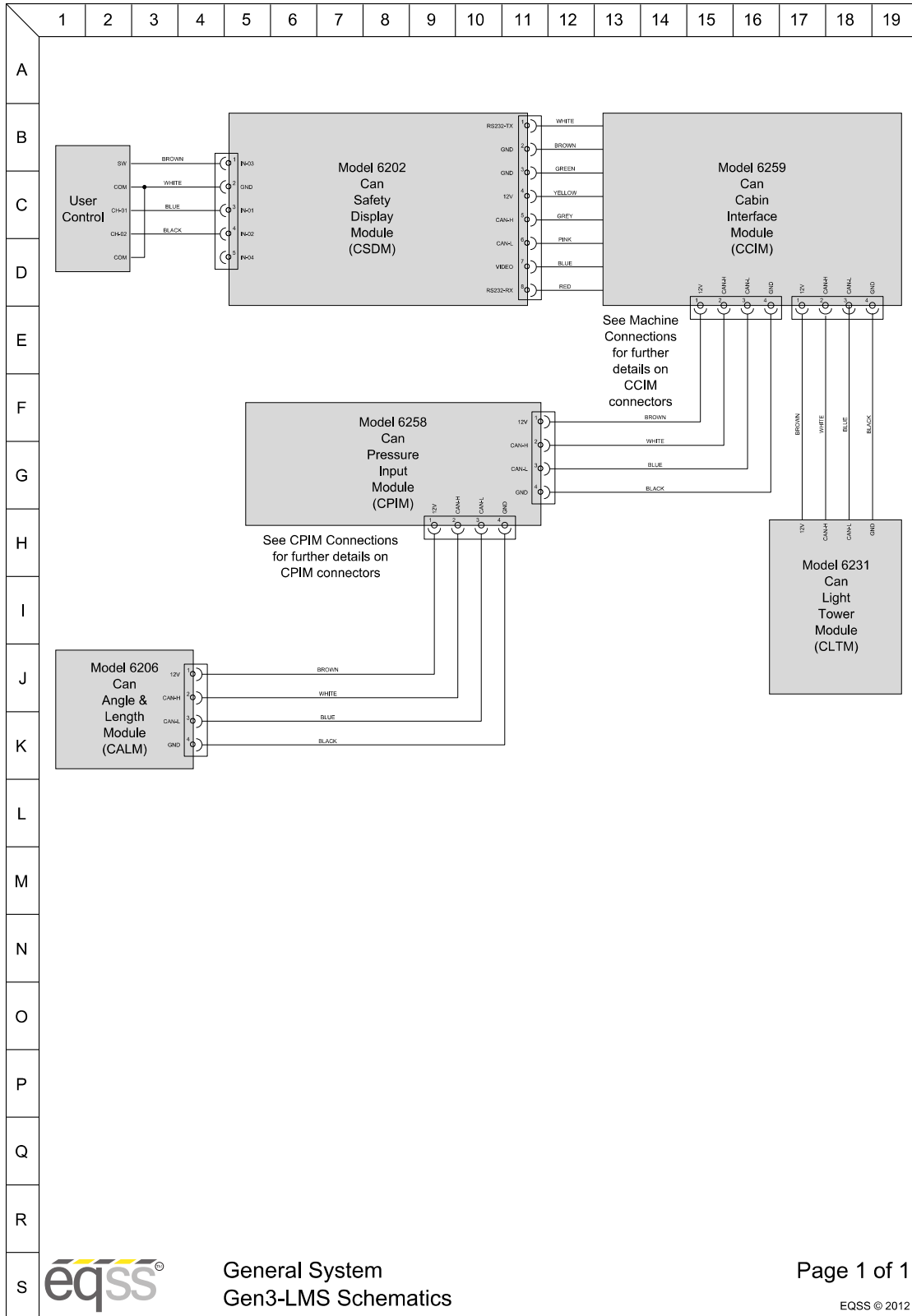

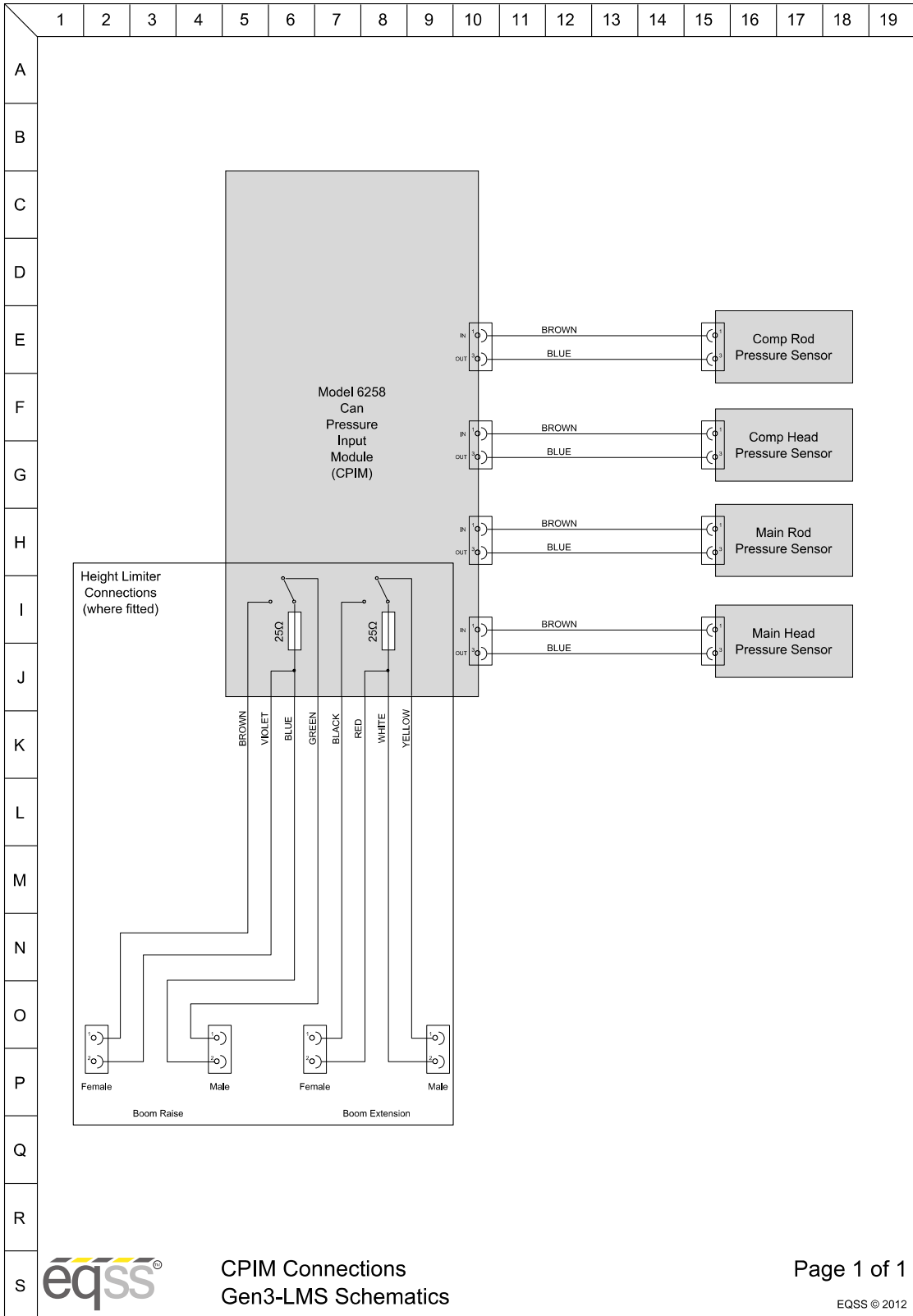

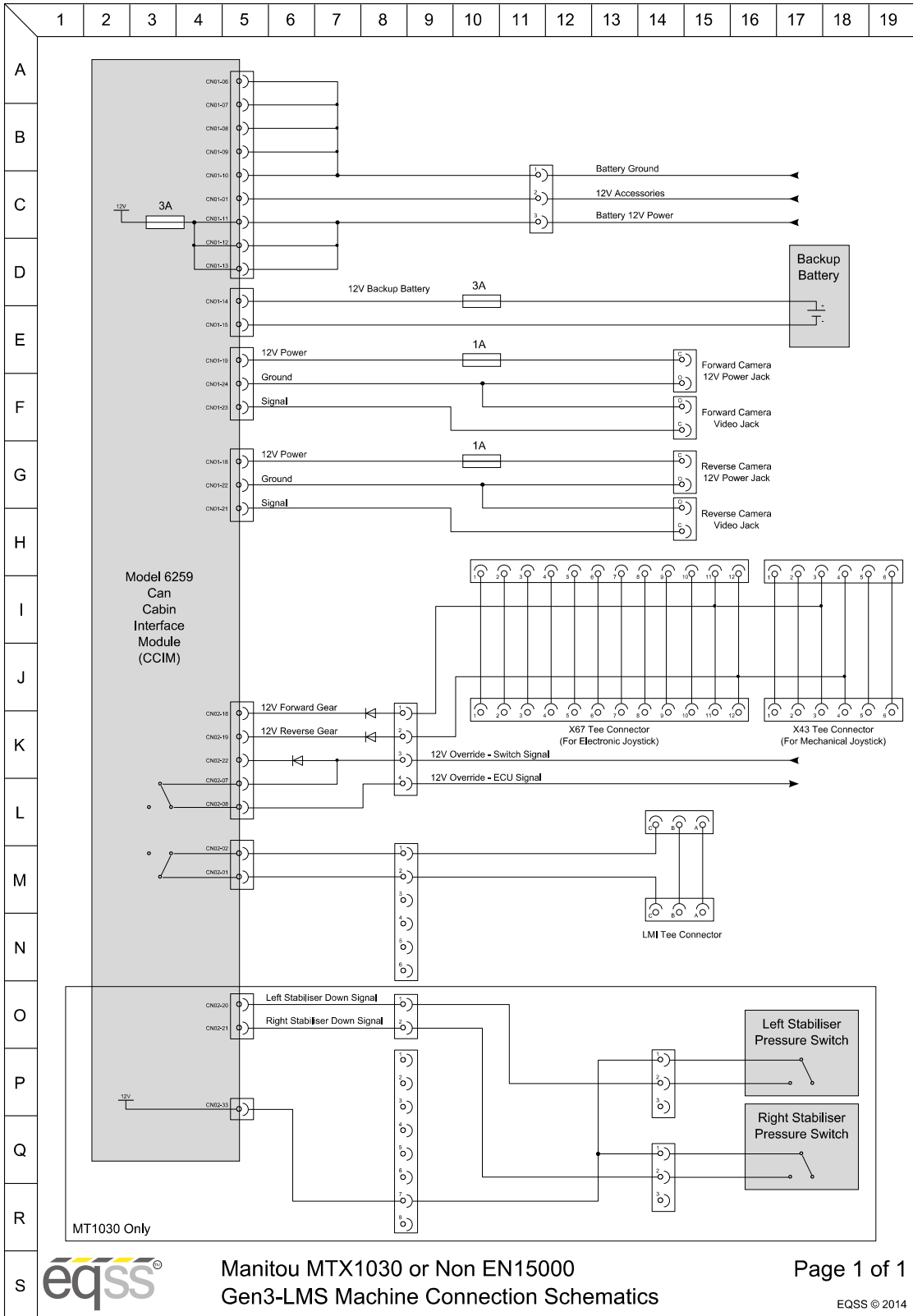

Indexes and Tables

Illustration Index

Illustration 1: Machine Boom.....	9
Illustration 2: Machine Chassis	10
Illustration 3: Cable Reeler Mounting Position.....	15
Illustration 4: Light Tower Bracket Mounting Position.....	27

Index of Tables

Table 1: Component Installation Index.....	7
Table 2: Cable Installation Index.....	8
Table 3: Cover removal.....	12
Table 4: Cable Reeler Installation.....	14
Table 5: Pressure Manifold Installation.....	17
Table 6: Compensation Pressure Sensor Installation.....	18
Table 7: Reverse Camera Installation.....	19
Table 8: Joystick Cable Harness Installation.....	21
Table 9: Forward Camera Installation.....	22
Table 10: Stabiliser Cable Harness Installation.....	25
Table 11: Light Tower Installation.....	26
Table 12: Can Pressure Input Module (CPIM) Installation.....	28
Table 13: External Cable Completion.....	30
Table 14: Display Installation.....	31
Table 15: User Input Control Installation.....	32
Table 16: CCIM Installation.....	33
Table 17: Cabin Loom Installation.....	36
Table 18: Finalisation.....	39
Table 19: Sensor Calibration.....	42

Equipment Safety Systems Pty. Ltd. ABN: 31 061 789 151
27 Cumberland Drive, Seaford 3198, Victoria, Australia

Tel: +61 3 8770 6555
Fax: +61 3 8770 6590
Web: www.eqss.com.au