



# eqss™ Gen-3 LMS Telehandler Load Management System

## Installation Manual for MHT860



**WARNING!**  
DO NOT HIGH PRESSURE  
WASH ANY OF THE GEN3  
COMPONENTS. FAILURE TO  
FOLLOW THIS WARNING  
WILL VOID WARRANTY

**\*\*\*Do Not Swap Components between Gen3-LMS kits\*\*\***

**When installing multiple Gen3-LMS kits, make sure the serial number on the sticker matches the serial number on the machine.**

**\*\*\*Failure To Follow Installation Manual Will Void Warranty\*\*\***

## Documentation Conventions

The list below highlights important documentation conventions.



Text presented in this manner is intended to provide the user with some general information. The user should ensure information presented in this manner is clearly understood.



Text presented in this manner provides the user with information to assist in completion of the current procedure being explained.



Text presented in this manner indicates that a failure to follow directions could result in damage to equipment, loss of information, bodily harm, or loss of life.

**Important Information**

Information contained in this publication regarding this device's applications and the like is provided only for your convenience and may be superseded by updates. It is your responsibility to ensure that the application or our equipment meets with your specifications.

EQUIPMENT SAFETY SYSTEMS MAKE NO REPRESENTATIONS OR WARRANTIES OF ANY KIND WHETHER EXPRESS OR IMPLIED, WRITTEN OR ORAL, STATUTORY OR OTHERWISE, RELATED TO THE INFORMATION, INCLUDING BUT NOT LIMITED TO, IT'S CONDITION, QUALITY, PERFORMANCE, MERCHANTABILITY OR FITNESS FOR PURPOSE.

Equipment Safety Systems disclaims all liability arising from this information and its use. Use of Equipment Safety Systems' products as critical components in life support systems is not authorised except with express written approval by Equipment Safety Systems. No licenses are conveyed, implicitly or otherwise, under any Equipment Safety Systems intellectual property rights.

# Table of Contents

Tools Required for Installation.....	5
Installation Index.....	6
Covers.....	10
Cable Reeler Installation.....	12
Cable Reeler Mounting Position.....	14
Pressure Sensor Installation.....	15
Pressure Manifold.....	15
Compensation Pressure Sensors.....	17
Reverse Camera.....	18
Forward Camera.....	20
Signal Light Installation.....	22
Can Pressure Input Module (CPIM).....	24
External Cable Completion.....	25
Display Installation.....	27
User Control.....	28
Can Cabin Interface Module (CCIM).....	29
Cabin Loom.....	30
Finalisation.....	33
Set Time & Sensor Calibration.....	36
Schematics.....	39
Appendix A: Attaching Display Connectors.....	42
Appendix B: Reattach Ferrites.....	46
Indexes and Tables.....	47

# Tools Required for Installation

The tools required to perform the installation of the TSS are listed below

- Pencil or Texta
- Drill
- Drill bits
  - 3.3 mm
  - 4.5 mm
  - 5 mm
  - 6.25 mm
  - 6.8 mm
  - 8.5 mm
- Centre punch
- Tap T-Handle
- Taps
  - M6
  - M7 x 0.75
  - M8
- Drill and tap oil
- Metric Allen keys
- Phillips Head screw driver
- Spanners and sockets
  - 7 mm
  - 10 mm
  - 13 mm
- Loctite thread locker
- Side cutters
- Stanley knife
- Crimpers
- Wire strippers

# Installation Index

The components and cables of the Gen-3 Telehandler Load Management System are outlined in the tables below. The following pages show where the components are installed and the cable routing.

See the appropriate manual section for a detailed installation description for each component.



Refer to this section for any component placement or cable routing issues

<i>Item</i>	<i>Component Description</i>
1	Cable Reeler
2	Main Lift Cylinder Pressure Sensors
3	Compensation Cylinder Pressure Sensors
4	Can Pressure Input Module (CPIM)
5	Light Tower
6	Rear Camera
7	Can Cabin Interface Module (CCIM)
8	Display Module
9	SPU Module
10	Joystick Connection (X167)

*Table 1: Component Installation Index*

<i>Colour</i>	<i>Cable Description</i>
Yellow	Boom Cable
Dark Green	Main Cylinder Pressure Sensor Cables
Dark Blue	Compensation Cylinder Pressure Sensors Cables
Light Green	Forward Camera Cable
Violet	Light Tower Cable
Aqua	Rear Camera Cable
Dark Yellow	CCIM Cable
Red	Display Cable
Orange	User Input Control Cable

*Table 2: Cable Installation Index*





*Illustration 1: Machine Boom*



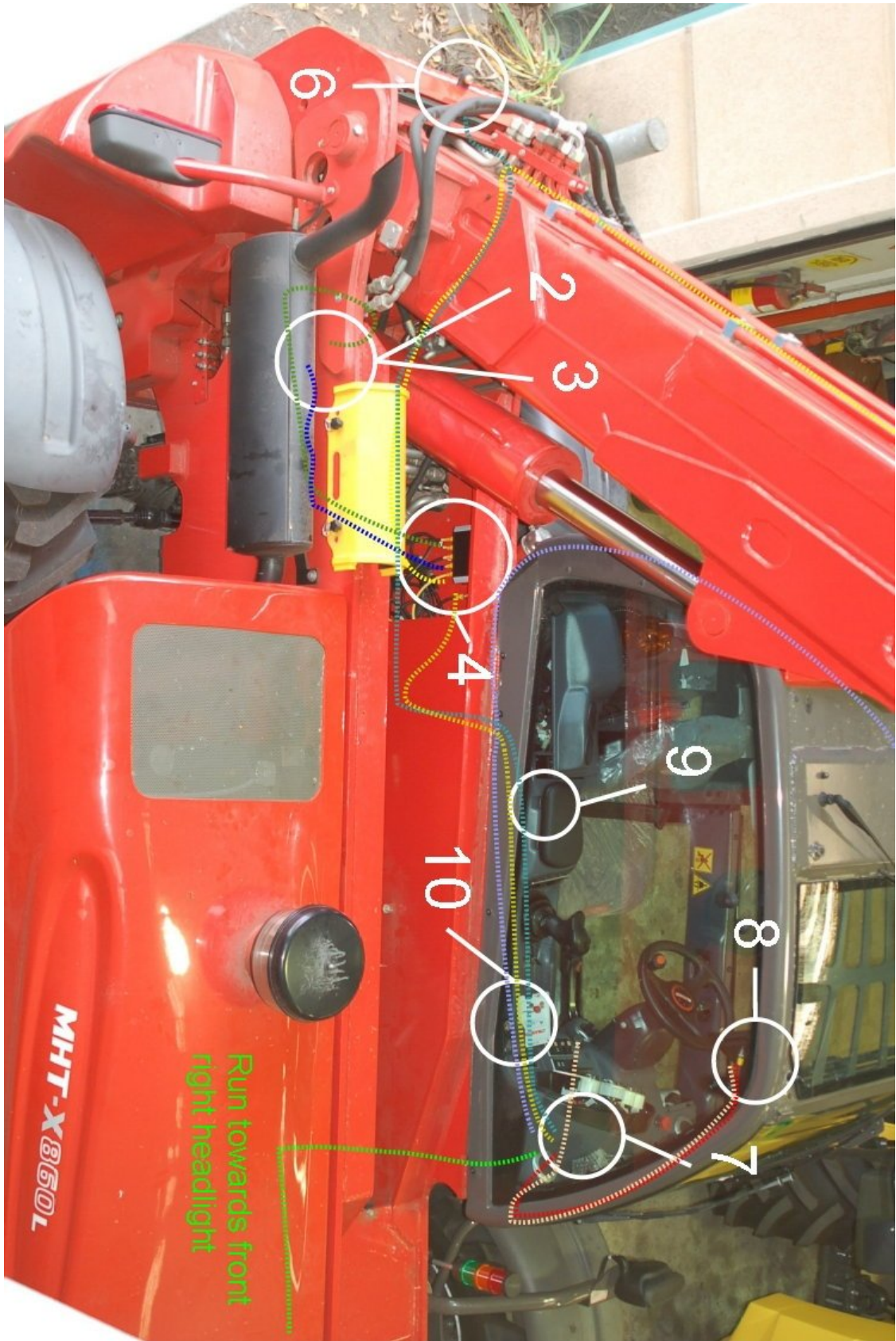



Illustration 2: Machine Chassis

Please Note: Old light tower is shown

# Covers

Remove the following covers before starting the installation

<i>Step</i>	<i>Description</i>	<i>Diagram</i>
1.	Remove the rear cover behind the machine.	
2.	Remove the covers behind the cabin and over the hydraulic spool manifold	
1.	Remove the cover below the boom and beside the cabin	
2.	Inside the cabin remove the dashboard display.	

<i>Step</i>	<i>Description</i>	<i>Diagram</i>
3.	Remove the covers along the right side of the drivers seat	

Table 3: Cover removal



# Cable Reeler Installation

The cable reeler is used to measure the boom extension to determine the maximum lifting capacity.



A false N07 fault can occur if the boom jumps off the stow switch due to pressurising the hydraulic system and without operating the boom extension control. Ensure the stow switch arm is correctly adjusted to prevent this error.

<i>Step</i>	<i>Description</i>	<i>Diagram</i>
1.	<p>Drill and tap the holes for the cable reeler according to the mounting diagram on page 14.</p> <p>Mount using the supplied standoffs, bolts and washers.</p>	
2.	<p>Drill and tap an M8 hole for the cable anchor. Ensure the cable anchor is positioned so the cable runs in line with the boom.</p> <p>Mount the cable anchor and attach the cable.</p>	
3.	<p>Adjust the stow switch trigger arm to ensure the stow switch is pressed when the boom is retracted.</p>	



<i>Step</i>	<i>Description</i>	<i>Diagram</i>
4.	Connect the supplied M12 10 metre cable (CB001027) into the cable reeler connection.	
5.	<p>Run the cable along the hydraulic pipes running down the boom, secure using cable ties every 150 mm to 200 mm.</p> <p>Cable tie to the flexible hydraulic hoses down to the chassis. Make sure the cable isn't pinched or stretched when the boom is raised or lowered.</p> <p>Cable tie with the other cables during External Cable Completion on page 25.</p>	

Table 4: Cable Reeler Installation



For further details on running the boom cable refer to the Installation Index on page 6

# Cable Reeler Mounting Position

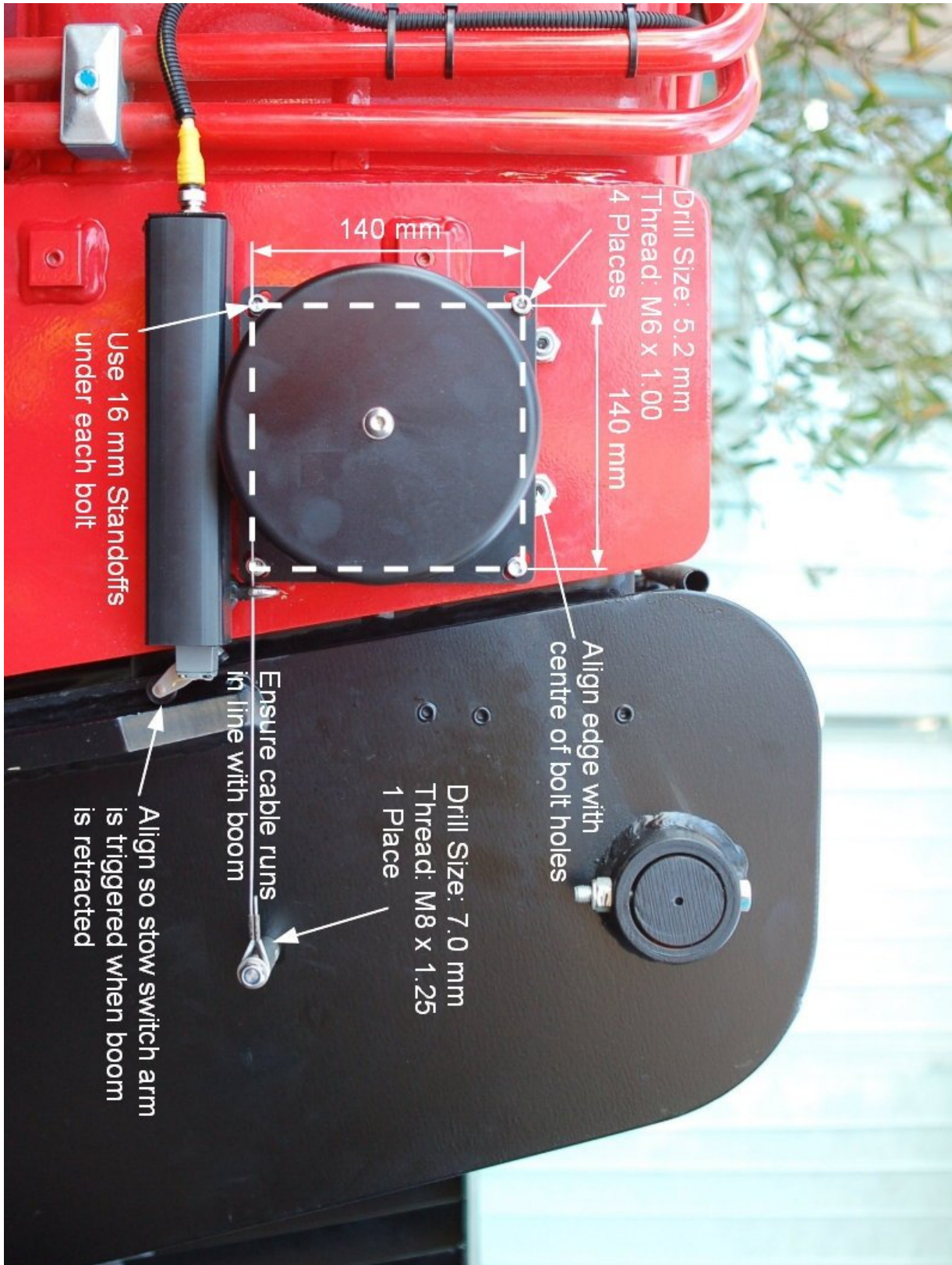



Illustration 3: Cable Reeler Mounting Position





# Pressure Sensor Installation

The hydraulic pressure sensors are used to measure the lifting load of the telehandler.

## Pressure Manifold

 Failure to tighten the bolts to the correct torque on the pressure manifold may result in a pressure failure on the counterbalance valve causing an uncontrolled fall of the boom.

<i>Step</i>	<i>Description</i>	<i>Diagram</i>
1.	<p>Raise the boom to approximately 65 degrees, to access the bolts on the counterbalance valve.</p> <p>Support and secure the boom using an A Frame or similar apparatus. <b>It must support at least 2 tons.</b></p> <p>Apply the handbrake and insert chock under wheels.</p> <p>Remove the counterbalance valve on the side of the hydraulic lifting ram.</p> <p><b>Removing the counterbalance valve will release the hydraulic pressure which may result in a spray of oil.</b></p> <p>Secure the pressure manifold using the supplied 80 mm bolts and seals. Tighten the bolts for the manifold to <b>25 NM</b> using a torque wrench.</p> <p><b>Start the machine, pressurise the boom and check for leaks.</b></p> <p><b>Ensure the pressure sensors and cables do not collide with the boom and chassis structures and the cables do not stretch or pinch when the boom is raised and lowered.</b></p>	  <p>Use lube on seals to hold in place during mounting</p>



<i>Step</i>	<i>Description</i>	<i>Diagram</i>
2.	<p>Connect the supplied M12 4 metre cables (CB001026) into each of the pressure sensors.</p> <p>Cable tie with the other cables during External Cable Completion on page 25.</p>	

*Table 5: Pressure Manifold Installation*

 For further details on running the pressure sensor cables refer to the Installation Index on page 6

# Compensation Pressure Sensors



<i>Step</i>	<i>Description</i>	<i>Diagram</i>
1.	<p>Install the two sets of pressure sensor and hydraulic tee connectors into the head and rod of the compensation cylinders</p> <p>Install the pressure sensor and hydraulic tee connector into the head of the compensation cylinders</p> <p><b>Start the machine, pressurise the boom and check for leaks.</b></p> <p>Connect the supplied M12 4 metre cables (CB001026) into each of the pressure sensors.</p> <p>Cable tie with the other cables during External Cable Completion on page 25.</p>	

Table 6: Compensation Pressure Sensor Installation



For further details on running the pressure sensor cables refer to the Installation Index on page 6

# Reverse Camera

The rear camera video is displayed on the screen when the machine is in reverse gear to allow the operator to see behind the telehandler while reversing.

 Do not disconnect the camera power connection while the system is operating as this can damage the fuse.



Step	Description	Diagram
1.	<p>Drill two M6 holes to mount the camera and a 20 mm hole for the cable in the location shown.</p> <p>Place the supplied high pressure washing sticker near the camera.</p>	
2.	<p>Connect the camera power and signal connectors to the supplied 5m camera cable (CB001032).</p> <p>Note; The white connector is not used.</p> <p>Secure the camera cable using a single cable tie to maintain the connector location.</p> <p>Run the remainder of the cable towards the cabin and insert into snake tube with the cabin cable during External Cable Completion on page 25.</p>	

Table 7: Reverse Camera Installation

 The camera's viewing angle may need to be adjusted once the system is installed and the display is operational.



Once the cable has been secured with a cable tie disconnect the cable to remove the rear cover until the installation is finalised



For further details on running the camera cable refer to the Installation Index on page 6

# Forward Camera

The forward camera video is displayed on the screen when the machine is in forward gear to allow the operator to see past the boom to obstructions that would damage the right front tyre.



Do not disconnect the camera power connection while the system is operating as this can damage the fuse.

<i>Step</i>	<i>Description</i>	<i>Diagram</i>
1.	<p>Mount the camera to the side mirror mount using the p-clips as shown.</p> <p>Secure using two M6 nuts.</p>	
2.	<p>Connect the camera power and signal connectors to the supplied 5m camera cable (CB001032).</p> <p>Note; The white connector is not used.</p> <p>Run the cable down the mirror post, then run the cable along the same path as the headlight cable under the chassis to the side of the cabin. Cable tie to the headlight cable every 150 mm to 200 mm.</p> <p>Complete the cable installation during External Cable Completion on page 25.</p>	

Table 8: Forward Camera Installation



The camera's viewing angle may need to be adjusted once the system is installed and the display is operational.





For further details on running the camera cable refer to the Installation Index on page 6

# Signal Light Installation

The signal light warns other workers when the telehandler is lifting loads close to its maximum capacity.



Ensure the power supply voltage is greater than 13.5V otherwise the signal light may not illuminate correctly.

<i>Step</i>	<i>Description</i>	<i>Diagram</i>
1.	Mount the signal light on the top of the roof past the roof window towards the cabin door.	
2.	Run the cable towards the boom side of the roof and push through the hole near the window wiper.  Note: It might be necessary to cut a hole in the plastic roof cover to fit the cable.  Run the cable under the cover towards the rear corner.	



<i>Step</i>	<i>Description</i>	<i>Diagram</i>
3.	<p>Run the cable along the pipes under the cover towards the chassis.</p> <p>Cable tie with the other cables during External Cable Completion on page 25.</p>	

*Table 9: Signal Light Installation*

# Can Pressure Input Module (CPIM)

The CPIM is responsible for processing the information sent from the pressure sensors.



Accidentally swapping the pressure sensor connections will not damage system and can be determined if the display is showing a negative load.



Do not plug the pressure sensor cable into the far right side boom cable. This will damage the system.





<i>Step</i>	<i>Description</i>	<i>Diagram</i>
1.	<p>Drill and tap two M8 holes for the CPIM bracket in the side of the chassis.</p> <p>Mount using the supplied M8 x 12mm bolts and washers.</p>	 <p>View from under the boom towards the rear of the cabin</p>
2.	<p>Connect the cables for the pressure sensors and boom cable to the CPIM according to the picture shown.</p> <p>Note: The CCIM cable will be installed during External Cable Completion on page 25.</p>	

Table 10: Can Pressure Input Module (CPIM) Installation

# External Cable Completion

All external cabling is completed in this step.

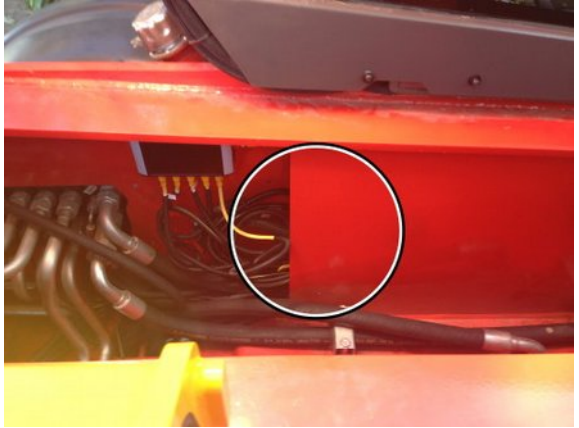
<i>Step</i>	<i>Description</i>	<i>Diagram</i>
1.	Coil up and cable tie the additional cabling for the pressure sensor and boom cables and store between the cabin and side plate under the boom.	
2.	Connect the supplied M12 4 metre cable (CB001026) into the free tee connection out of the right side of the CPIM for the CCIM cable.	
3.	Cable tie the CCIM, signal light and rear camera harnesses together and insert through the hole into the cabin behind the seat.	



<i>Step</i>	<i>Description</i>	<i>Diagram</i>
4.	<p>Once into the cabin run the cables underneath the side panel to the front of the dashboard display.</p> <p>Note: Pull only enough of the cables through into the cabin to reach the dashboard display, store the remaining cable between the cabin and side plate under the boom.</p>	
5.	<p>Run the forward camera through the hole into the cabin near the front of the dashboard.</p> <p>Note: Pull only enough of the cable through into the cabin to reach the dashboard display, store the remaining cable between the cabin and side plate under the boom.</p>	 <p>View from behind and under the front left tyre up towards the cabin</p>

Table 11: External Cable Completion



For further details on running the cables refer to the Installation Index on page 6

# Display Installation

The display shows the current safety status of the telehandler.

<i>Step</i>	<i>Description</i>	<i>Diagram</i>
1.	Attach the display bracket to the level indicator in the top right corner using the supplied M6 x 35 mm bolts and nuts.  Attach the display to the bracket and tighten the grub screw	

Table 12: Display Installation



Adjust the display bracket for optimal viewing angle once the display is powered



If the M12 screw lock connectors on the display are over tightened it will twist the connector pins attaching the connector to the PCB. See Appendix A: Attaching Display Connectors on page 42 for the correct method of attaching to the display connectors.

# User Control

The user control consists of a single dial switch mounted in the dashboard.

<i>Step</i>	<i>Description</i>	<i>Diagram</i>
1.	Drill a 34 mm hole into the cover in front of the joystick and install the user control dial.	

Table 13: User Control Installation



# Can Cabin Interface Module (CCIM)

The CCIM connects the system into the machine electronics.



<i>Step</i>	<i>Description</i>	<i>Diagram</i>
1.	<p>Position the backup battery (to the left of the CCIM) underneath the dashboard using double sided velcro tape.</p> <p>Position the CCIM to the right of the backup battery using double sided velcro tape.</p> <p>Remove the battery and CCIM from the velcro to allow the connections to be completed. Reattach to the velcro in the section Finalisation on page 33.</p>	

Table 14: CCIM Installation





# Cabin Loom

The cabin loom connects the CCIM to the machine connections and the other modules of the system.

 Isolate the main battery before connecting into the machine wiring

 Do not disconnect the camera power connection while the system is operating as this can damage the fuse.

<i>Step</i>	<i>Description</i>	<i>Diagram</i>
1.	<p>Connect the CCIM and signal light cables to the M12 connectors on the CCIM.</p> <p>Note: It doesn't matter which of the M12 connectors the CCIM and signal light cables are plugged into.</p>	
2.	<p>Connect the Power/Camera and IO Harnesses to the bulkhead connectors on the CCIM.</p>	



<i>Step</i>	<i>Description</i>	<i>Diagram</i>
3.	<p>Connect the camera power and signal cables to the cabin loom.</p> <p>Note: The white connector is not used.</p>	
4.	<p>Run the 8 pin and 5 pin cables from the CCIM and user control through the gap between the window and the dashboard.</p> <p>Connect into the 8 pin and 5 pin connectors on the rear of the display</p>	
5.	<p>Run the cables through snake tube.</p> <p>Place cable tie points on the side of the window.</p> <p>Cable tie the snake tube to the cable tie points.</p>	

Table 15: Cabin Loom Installation





If the M12 screw lock connectors on the display are over tightened it will twist the connector pins attaching the connector to the PCB. See Appendix A: Attaching Display Connectors on page 42 for the correct method of attaching to the display connectors.





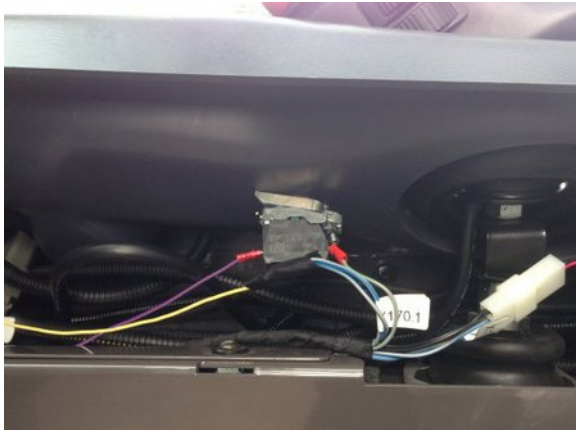

If the clip-on ferrites were removed from the CCIM and user control cables. See Appendix B: Reattach Ferrites and page 46 for the correct reattachment position.

# Finalisation

This section will complete the final power connections to power the system and finish any additional items.

<i>Step</i>	<i>Description</i>	<i>Diagram</i>
1.	<p>Locate the connector under the side panel in the cabin that connect into the joystick.</p> <p>Connect the supplied machine input harness with the tee connectors to the joystick connector.</p>	
2.	<p>Locate the override key switch in front of the joystick.</p> <p>Release the spade terminal from the switch connecting the two blue/grey wires and replace with the spade terminal with the purple wire from the machine input harness.</p> <p>Join the two blue/grey wires to the yellow wire from the machine input harness.</p> <p>Connect the 4 pin connector to the cabin loom connector.</p>	
3.	<p>Locate the SPU unit under the side panel next to the cabin towards the rear.</p> <p>Remove the connectors from the SPU and insert the cutout terminal into B21 (where B is the larger connector) from the cutout harness.</p>	

<i>Step</i>	<i>Description</i>	<i>Diagram</i>
4.	<p>Locate the power connector for the radio (X238).</p> <p>Connect the radio power tee connectors from the radio power harness to the power connector for the radio.</p>	
5.	<p>Connect the 4 pin connector from the machine input harness to the cabin loom.</p> <p>Connect the 6 and 12 pin connectors from the cutout harness to the cabin loom.</p> <p>Connect the 3 pin connector from the power harness to the cabin loom.</p>	
6.	<p>Connect the spade lug on the black wire to the negative (black) battery terminal.</p> <p>Connect the spade lug on the blue wire to the positive (red) battery terminal.</p>	
7.	<p>Attach the backup battery and CCIM to the velcro strips installed earlier.</p>	





<i>Step</i>	<i>Description</i>	<i>Diagram</i>
8.	<p>Adjust the display bracket for optimal viewing</p> <p>Set the machine into forward gear to activate the forward camera. Adjust the forward camera so the front right wheel is visible.</p> <p>Set the machine into reverse gear to activate the reverse camera. Adjust the reverse camera so the video is level.</p>	
9.	<p>Operate the boom movement controls to test if a false N07 fault occurs.</p> <p>If a N07 fault does occur, adjust the arm on the stow switch forwards towards the stow switch trigger.</p> <p>Note: The actual switch arm orientation may differ from the picture.</p>	
10.	<p>Perform a final check on all the cabling and sensors.</p> <p>Replace all the covers</p>	

Table 16: Finalisation

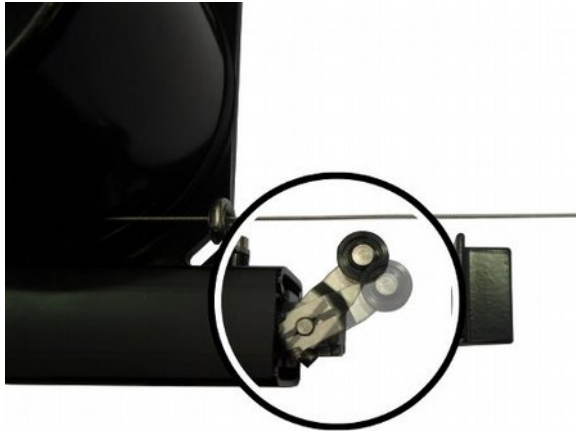

Complete the system checklist once installation has been completed.

# Set Time & Sensor Calibration

Once the installation is complete, the time will need to be set and the sensors will require calibration.



A sensor calibration must be performed once the cable reeler and CPIM have been mounted. If the cable reeler or CPIM have been moved/repositioned a recalibration must be performed

<i>Step</i>	<i>Description</i>	<i>Diagram</i>
1.	<p>Press Enter on the user control dial to enter the menu system.</p> <p>Press the arrow buttons to select System Menu.</p> <p>Press Enter to select the menu.</p>	<div style="border: 1px solid black; padding: 5px;"> <p style="text-align: center; margin: 0;"><b>Main Menu</b></p> <hr/> <p style="text-align: center; margin: 0;">Attachment Selection Menu</p> <div style="background-color: #4a7ebb; color: white; text-align: center; padding: 5px; margin: 5px 0;"> <p style="margin: 0;">System Menu</p> </div> <p style="text-align: center; margin: 0;">Exit Menu</p> <hr/> </div>
2.	Select Advanced Menu	<div style="border: 1px solid black; padding: 5px;"> <p style="text-align: center; margin: 0;"><b>System Menu</b></p> <hr/> <p style="text-align: center; margin: 0;">Volume / Brightness</p> <hr/> <p style="text-align: center; margin: 0;">Status Menu</p> <hr/> <p style="text-align: center; margin: 0;">Diagnostics Menu</p> <hr/> <p style="text-align: center; margin: 0;">System Tests</p> <div style="background-color: #4a7ebb; color: white; text-align: center; padding: 5px; margin: 5px 0;"> <p style="margin: 0;">Advanced Menu</p> </div> <p style="text-align: center; margin: 0;">Return to Main Menu</p> <hr/> </div>



<i>Step</i>	<i>Description</i>	<i>Diagram</i>														
3.	Enter the password (Default Password: 2-8-4)	<table border="1"> <thead> <tr> <th colspan="2"><i>Enter Password</i></th> </tr> </thead> <tbody> <tr> <td>Number 1</td> <td>2</td> </tr> <tr> <td>Number 2</td> <td>8</td> </tr> <tr> <td>Number 3</td> <td>4</td> </tr> <tr> <td colspan="2">Submit Password</td> </tr> <tr> <td colspan="2">Return to System Menu</td> </tr> </tbody> </table>	<i>Enter Password</i>		Number 1	2	Number 2	8	Number 3	4	Submit Password		Return to System Menu			
<i>Enter Password</i>																
Number 1	2															
Number 2	8															
Number 3	4															
Submit Password																
Return to System Menu																
4.	Select Set Time / Date	<table border="1"> <thead> <tr> <th colspan="2"><i>Advanced Settings</i></th> </tr> </thead> <tbody> <tr> <td colspan="2">Set Time / Date</td> </tr> <tr> <td colspan="2">Sensor Calibrations</td> </tr> <tr> <td colspan="2">Change Language</td> </tr> <tr> <td colspan="2">Change Password</td> </tr> <tr> <td colspan="2">Return to System Menu</td> </tr> </tbody> </table>	<i>Advanced Settings</i>		Set Time / Date		Sensor Calibrations		Change Language		Change Password		Return to System Menu			
<i>Advanced Settings</i>																
Set Time / Date																
Sensor Calibrations																
Change Language																
Change Password																
Return to System Menu																
5.	<p>Enter the correct time and date for your area.</p> <p>Press the arrow keys to select a time/date parameter</p> <p>Press Enter and the parameter will change to red, press the arrow keys to change the value and then press the Enter key to store the value.</p> <p>Note: The hour parameter is in 24 hour clock</p> <p>Repeat for the rest of the time values</p>	<table border="1"> <thead> <tr> <th colspan="2"><i>Set Time / Date</i></th> </tr> </thead> <tbody> <tr> <td>Hour</td> <td>15</td> </tr> <tr> <td>Minute</td> <td>54</td> </tr> <tr> <td>Day</td> <td>10</td> </tr> <tr> <td>Month</td> <td>2</td> </tr> <tr> <td>Year</td> <td>2016</td> </tr> <tr> <td>Region</td> <td>Melbourne</td> </tr> </tbody> </table>	<i>Set Time / Date</i>		Hour	15	Minute	54	Day	10	Month	2	Year	2016	Region	Melbourne
<i>Set Time / Date</i>																
Hour	15															
Minute	54															
Day	10															
Month	2															
Year	2016															
Region	Melbourne															

<i>Step</i>	<i>Description</i>	<i>Diagram</i>
6.	Scroll to the next page and select Save to store the new time/date and return to the Advanced Menu.	<p>The diagram shows a menu with a blue highlighted button labeled "Save" and a text option below it labeled "Return to Advanced Menu".</p>
7.	Select Sensor Calibrations	<p>The diagram shows a menu titled "Advanced Settings" with options: "Set Time / Date", "Sensor Calibrations" (highlighted in blue), "Change Language", "Change Password", and "Return to System Menu".</p>
8.	Select Calibrate Carrier Angle and then follow the instructions on the screen to complete the calibration.  Repeat for Calibrate Boom Angle and Calibrate Boom Length.	<p>The diagram shows a menu titled "Sensor Calibration Menu" with options: "Calibrate Carrier Angle" (highlighted in blue), "Calibrate Boom Angle", "Calibrate Boom Length", and "Return to Advanced Menu".</p>

Table 17: Sensor Calibration

# Schematics

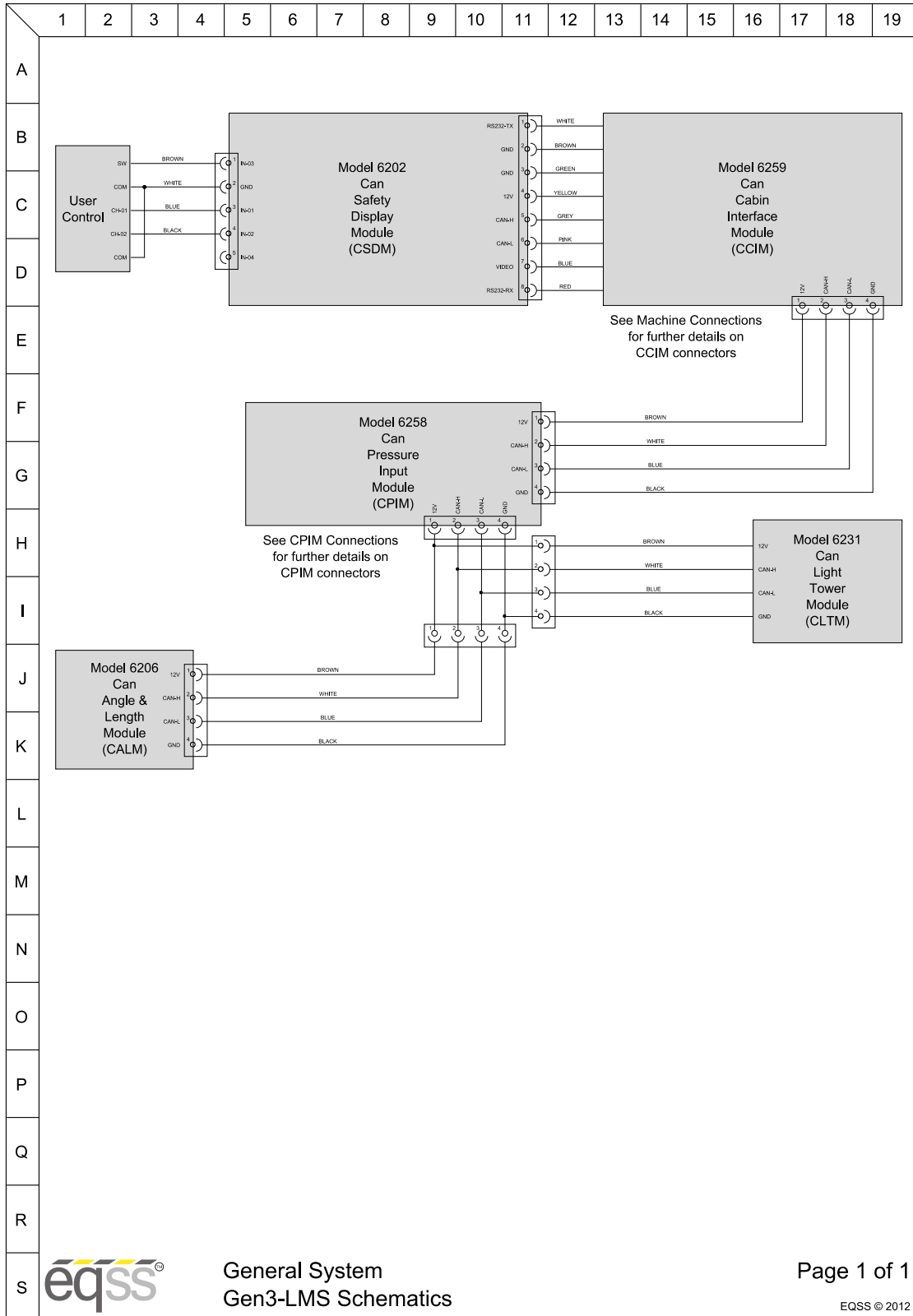

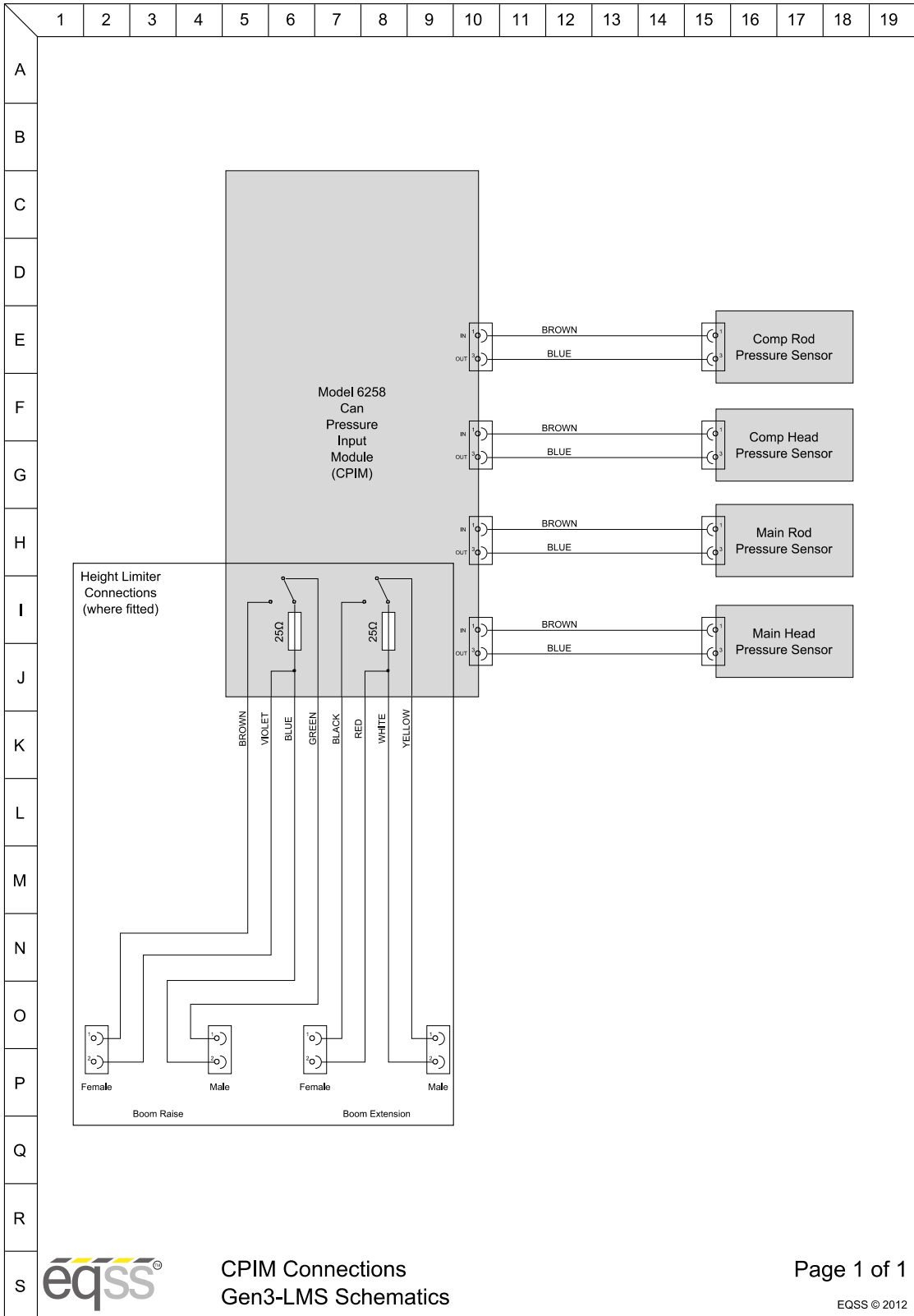

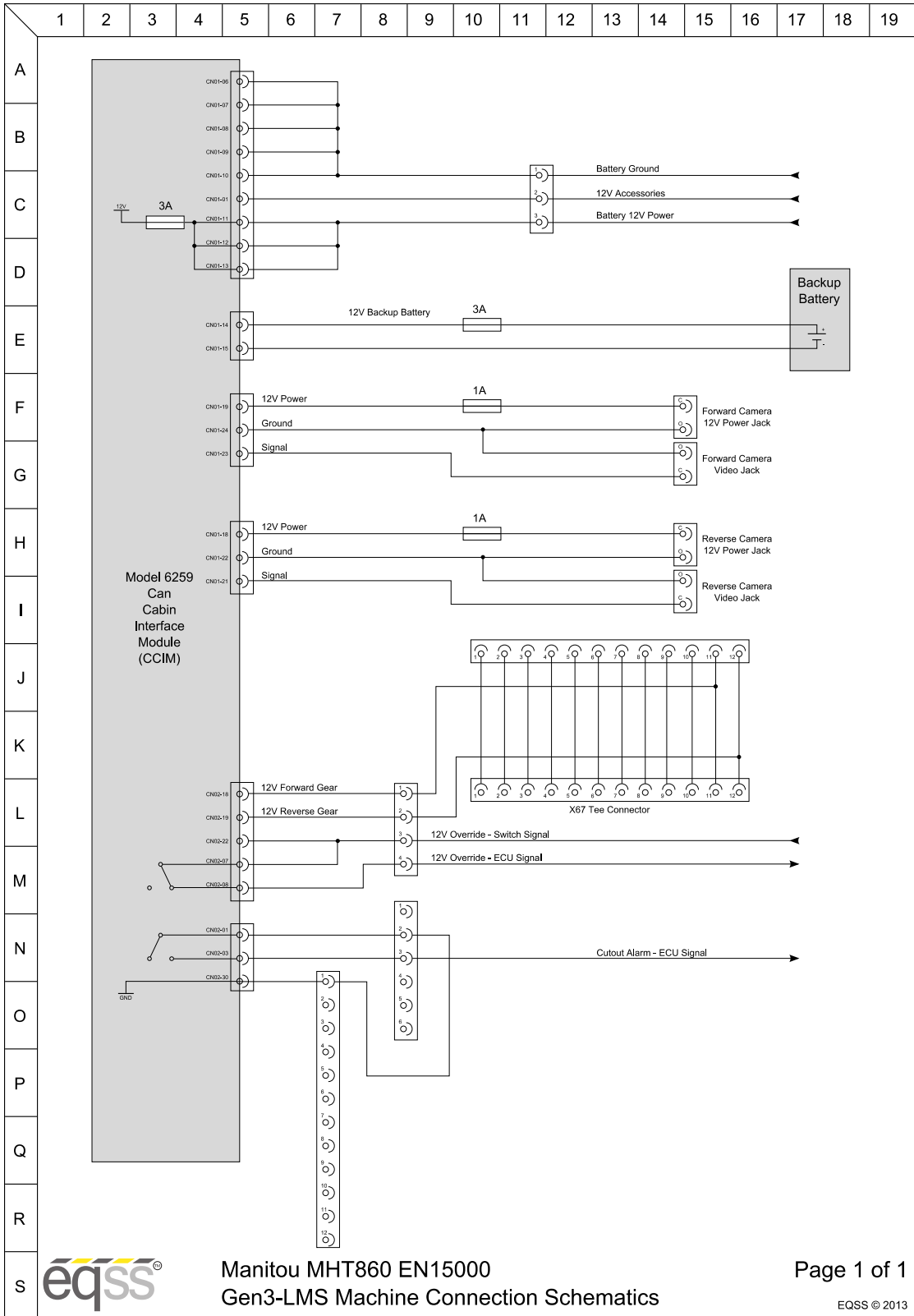

# Appendix A: Attaching Display Connectors

The procedure below describes the correct method of attaching the cables to the screw lock connectors on the display.



If the M12 screw lock connectors on the display are over tightened, it will twist the connector pins attaching the connector to the PCB.

<i>Step</i>	<i>Description</i>	<i>Diagram</i>
1.	<p>Connect the cable from the user control to the top 5 pin connector on the display.</p> <p>Connect the cable from the CCIM to the bottom 8 pin connector on the display.</p>	
2.	<p>Line up the alignment hole on the cable connector with the alignment notch on the display connector.</p>	



<i>Step</i>	<i>Description</i>	<i>Diagram</i>
3.	Push the female connector from the cable into the male connector on the display.	
4.	Rotate the nut on the female connector by hand in a clockwise direction, until the tension on the nut starts to increase.	
5.	Push the cable in again and repeat steps 3 and 4 until the connector is secure.	

Table 18: Install Display Connector Procedure



The method to correctly secure the cable is to push-twist-push-twist until the connector is fully inserted and secure. This will minimise the twisting force applied to the connector.

Below is a picture of a damaged connector on the PCB inside the display. This damaged occurred because the connector was over tightened.



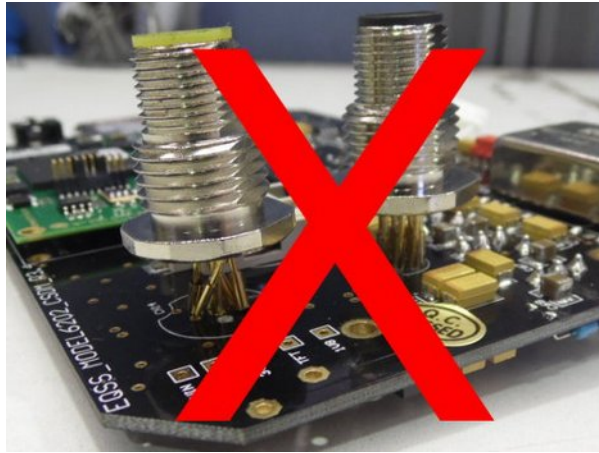

*Illustration 4: Damaged Display Connector*



Do not use any tools to tighten the connector.



*Illustration 5: Do Not Use Tools To Tighten Connector*



Do not over-tighten the nuts on the back of the display connectors. These nuts should only be hand tightened. If the nuts are overtightened it will damage the PCB inside the display.



*Illustration 6: Do Not Over Tighten Nuts*



Damage to the display connectors is not covered under warranty.

# Appendix B: Reattach Ferrites

If the clip-on ferrites on the displays are removed during installation, they will need to be reattached as shown in the procedure below.

 If the ferrites are not reinstalled or attached in the specified location the Gen3-LMS kit will not meet the AS/NZS CISPR 22:2006 certification.

<i>Step</i>	<i>Description</i>	<i>Diagram</i>
1.	<p>Attach the two clip-on ferrites at a location of 60 mm and 260 mm from the start of the connector to the start of the ferrite.</p> <p>Do this for both the CCIM and user control cables that plug into the display.</p>	

Table 19: Reattach Ferrites Procedure

# Indexes and Tables

## Illustration Index

Illustration 1: Machine Boom.....	8
Illustration 2: Machine Chassis.....	9
Illustration 3: Cable Reeler Mounting Position.....	14
Illustration 4: Damaged Display Connector.....	44
Illustration 5: Do Not Use Tools To Tighten Connector.....	44
Illustration 6: Do Not Over Tighten Nuts.....	45

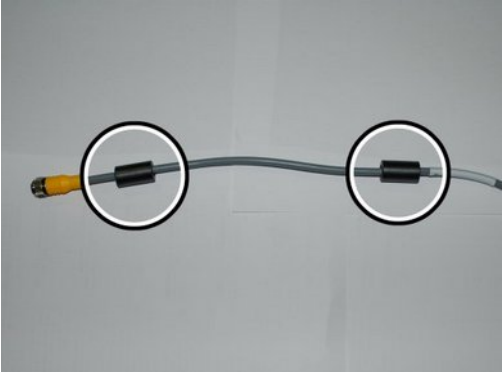
## Index of Tables

Table 1: Component Installation Index.....	6
Table 2: Cable Installation Index.....	7
Table 3: Cover removal.....	11
Table 4: Cable Reeler Installation.....	13
Table 5: Pressure Manifold Installation.....	16
Table 6: Compensation Pressure Sensor Installation.....	17
Table 7: Reverse Camera Installation.....	18
Table 8: Forward Camera Installation.....	20
Table 9: Signal Light Installation.....	23
Table 10: Can Pressure Input Module (CPIM) Installation.....	24
Table 11: External Cable Completion.....	26
Table 12: Display Installation.....	27
Table 13: User Control Installation.....	28
Table 14: CCIM Installation.....	29
Table 15: Cabin Loom Installation.....	31
Table 16: Finalisation.....	35
Table 17: Sensor Calibration.....	38
Table 18: Install Display Connector Procedure.....	43
Table 19: Reattach Ferrites Procedure.....	46

---

**Equipment Safety Systems Pty. Ltd.** ABN: 31 061 789 151  
27 Cumberland Drive, Seaford 3198, Victoria, Australia

Tel: +61 3 8770 6555  
Fax: +61 3 8770 6590  
Web: [www.eqss.com.au](http://www.eqss.com.au)