



eqss™ Gen-3 LMS Telehandler Load Management System

Installation Manual for JCB 541-70 Agri Super



PLEASE NOTE:

*****Do Not Swap Components between Gen3-LMS kits***
When installing multiple Gen3-LMS kits, make sure the serial
number on the sticker matches the serial number on the
machine.**

*****Failure To Follow Installation Manual Will Void Warranty*****

Documentation Conventions

The list below highlights important documentation conventions.



Text presented in this manner is intended to provide the user with some general information. The user should ensure information presented in this manner is clearly understood.



Text presented in this manner provides the user with information to assist in completion of the current procedure being explained.



Text presented in this manner indicates that a failure to follow directions could result in damage to equipment, loss of information, bodily harm, or loss of life.

Important Information

Information contained in this publication regarding this device's applications and the like is provided only for your convenience and may be superseded by updates. It is your responsibility to ensure that the application or our equipment meets with your specifications.

EQUIPMENT SAFETY SYSTEMS MAKE NO REPRESENTATIONS OR WARRANTIES OF ANY KIND WHETHER EXPRESS OR IMPLIED, WRITTEN OR ORAL, STATUTORY OR OTHERWISE, RELATED TO THE INFORMATION, INCLUDING BUT NOT LIMITED TO, IT'S CONDITION, QUALITY, PERFORMANCE, MERCHANTABILITY OR FITNESS FOR PURPOSE.

Equipment Safety Systems disclaims all liability arising from this information and its use. Use of Equipment Safety Systems' products as critical components in life support systems is not authorised except with express written approval by Equipment Safety Systems. No licenses are conveyed, implicitly or otherwise, under any Equipment Safety Systems intellectual property rights.

Table of Contents

Tools Required for Installation.....	6
Installation Index.....	8
Covers.....	12
Cable Reeler Installation.....	14
Cable Reeler Mounting Position.....	16
Pressure Sensor Installation.....	17
Main Cylinder Pressure Sensors.....	17
Compensation Pressure Sensors.....	19
Reverse Camera.....	21
Forward Camera.....	23
Light Tower Installation.....	25
Light Tower Bracket Mounting Position.....	26
Can Pressure Input Module (CPIM).....	27
Can Cabin Interface Module (CCIM).....	29
External Cable Completion.....	33
Dashboard Switches.....	35
Display Installation.....	36
Dashboard Cables.....	37
Machine Connections.....	39
Finalisation.....	42
Set Time & Sensor Calibration.....	45
Appendix A: Attaching Display Connectors.....	48
Appendix B: Reattach Ferrites.....	52

Indexes and Tables.....53

Tools Required for Installation

The tools required to perform the installation of the TSS are listed below

- Pencil or Texta
- Drill
- Drill bits
 - 3.3 mm
 - 4.5 mm
 - 5 mm
 - 6.25 mm
 - 6.8 mm
 - 8.5 mm
- Centre punch
- Tap T-Handle
- Taps
 - M6
 - M7 x 0.75
 - M8
- Drill and tap oil
- Metric Allen keys
- Phillips Head screw driver
- Spanners and sockets
 - 7 mm
 - 10 mm
 - 13 mm
- Loctite thread locker
- Side cutters
- Stanley knife
- Crimpers
- Wire strippers
- Hole saw
 - 31 mm
 - 34 mm

Installation Index

The components and cables of the Gen-3 Telehandler Load Management System are outlined in the tables below. The following pages show where the components are installed and the cable routing.

See the appropriate manual section for a detailed installation description for each component.

 Refer to this section for any component placement or cable routing issues

<i>Item</i>	<i>Component Description</i>
1	Cable Reeler
2	Main Lift Cylinder Head Pressure Sensor
3	Main Lift Cylinder Rod Pressure Sensor
4	Can Pressure Input Module (CPIM)
5	Forward Camera
6	Light Tower
7	Can Cabin Interface Module (CCIM)
8	Display Module

Table 1: Component Installation Index

<i>Colour</i>	<i>Cable Description</i>
Red	Boom Cable
Dark Green	Main Cylinder Head Pressure Sensor Cable
Brown	Main Cylinder Rod Pressure Sensor Cable
Dark Blue	Compensation Cylinder Pressure Sensors Cables
Light Blue	Forward Camera Cable
Violet	Light Tower Cable
Aqua	Rear Camera Cable
Dark Purple	CCIM Cable
Light Green	Cutout Harness
Dark Yellow	Machine Input Harness
Light Purple	Height Limiter Cable
Orange	Display Cable

Table 2: Cable Installation Index



Illustration 1: Machine Boom

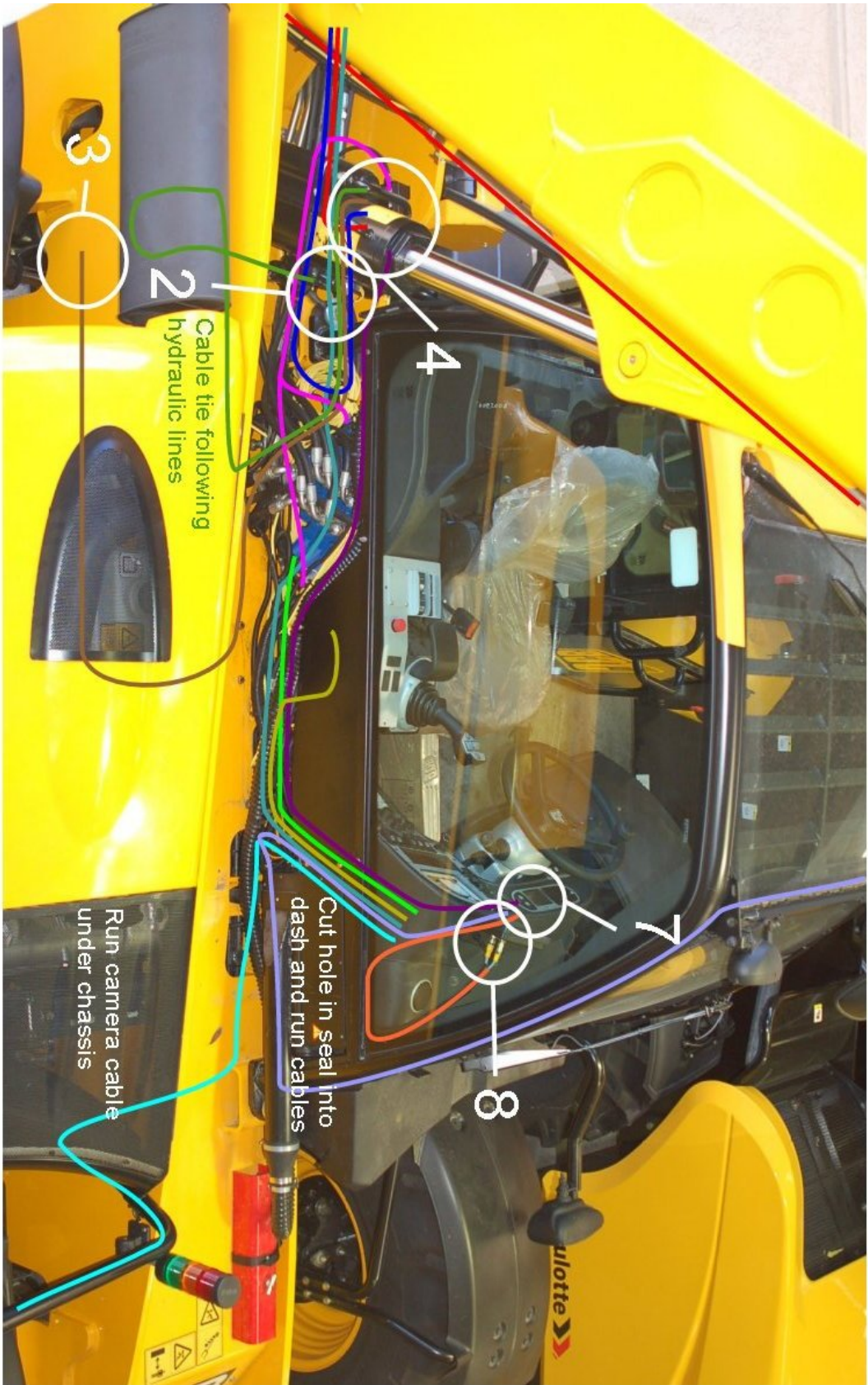
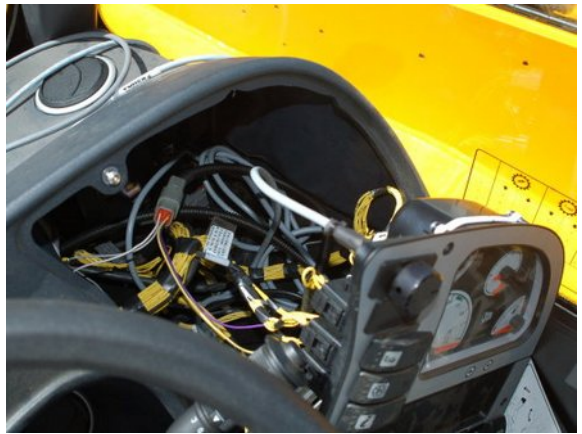



Illustration 2: Machine Chassis

Covers

Remove the following covers before starting the installation

<i>Step</i>	<i>Description</i>	<i>Diagram</i>
1.	Release the dashboard display bolts	
2.	Remove the indicator display behind the steering wheel	
3.	Release the cover beside the joystick	



<i>Step</i>	<i>Description</i>	<i>Diagram</i>
4.	Remove the side panel next to the cabin under the boom.	
5.	Remove the covers under the boom.	

Table 3: Cover removal

Cable Reeler Installation

The cable reeler is used to measure the boom extension to determine the maximum lifting capacity.



A false N07 fault can occur if the boom jumps off the stow switch due to pressurising the hydraulic system and without operating the boom extension control. Ensure the stow switch arm is correctly adjusted to prevent this error.

<i>Step</i>	<i>Description</i>	<i>Diagram</i>
1.	<p>Drill and tap the holes for the cable reeler according to the mounting diagram on page 16.</p> <p>Mount using the supplied M6 x 12 mm bolts and washers.</p>	
2.	<p>Drill and tap an M8 hole for the cable anchor. Ensure the cable anchor is positioned so the cable runs in line with the boom.</p> <p>Mount the cable anchor and secure the cable to the anchor.</p>	
3.	<p>Drill and tap the M6 holes for the stow switch trigger. Ensure the stow switch is pressed when the boom is retracted.</p> <p>Mount the stow switch trigger using the supplied M6 x 30 mm bolts and 17 mm standoffs.</p>	



<i>Step</i>	<i>Description</i>	<i>Diagram</i>
4.	Connect the supplied M12 10 metre cable (CB001027) into the cable reeler connection.	
5.	<p>Run the cable along the hydraulic pipes running down the boom, secure using cable ties every 150 mm to 200 mm.</p> <p>Cable tie to the flexible hydraulic hoses down to the chassis. Make sure the cable isn't pinched or stretched when the boom is raised or lowered.</p> <p>Run the cable towards the cabin and cable tie with the other cables during External Cable Completion on page 33.</p>	

Table 4: Cable Reeler Installation

 For further details on running the boom cable refer to the Installation Index on page 8

Cable Reeler Mounting Position

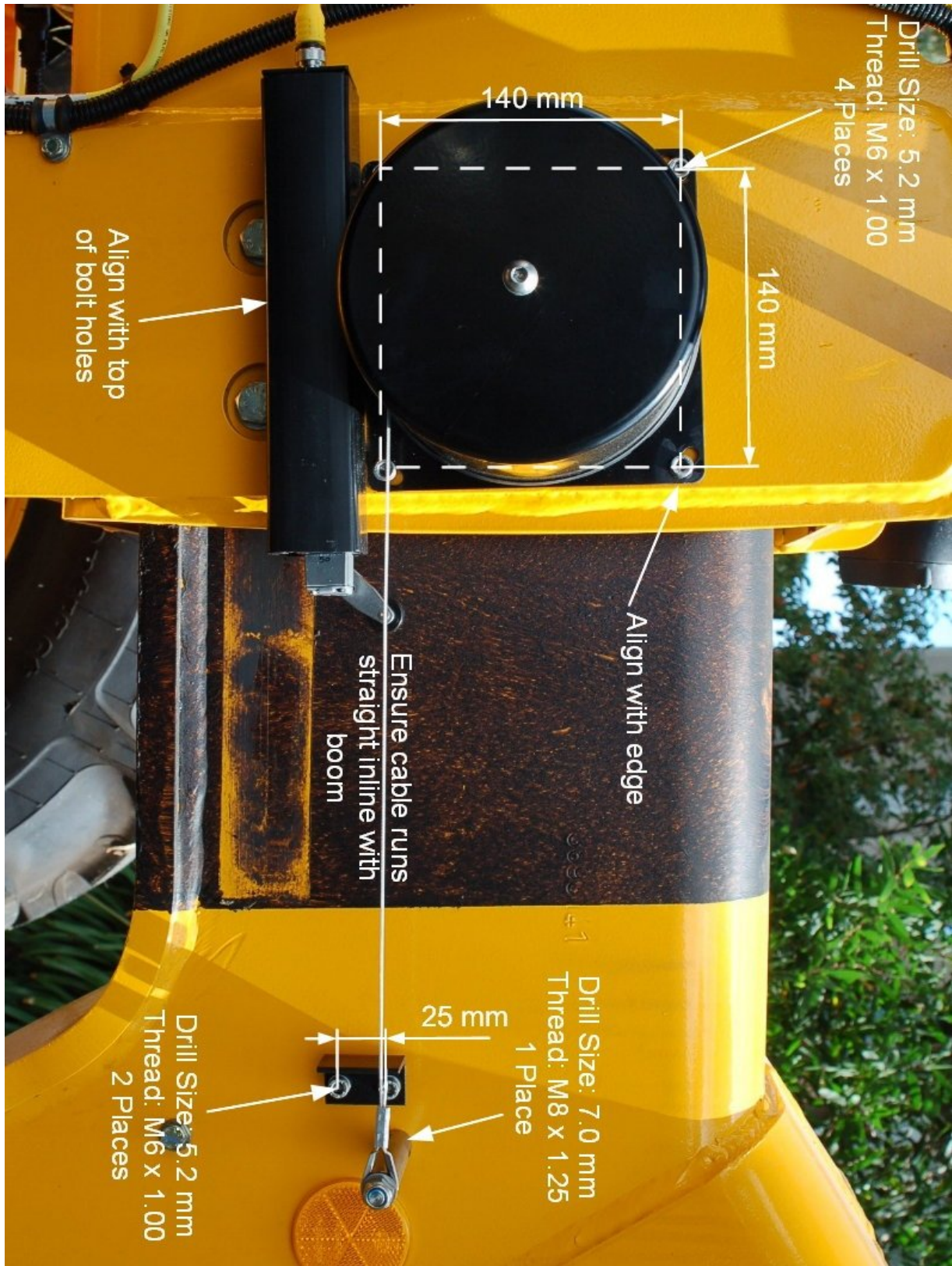



Illustration 3: Cable Reeler Mounting Position

Pressure Sensor Installation

The hydraulic pressure sensors are used to measure the lifting load of the telehandler.

Main Cylinder Pressure Sensors

<i>Step</i>	<i>Description</i>	<i>Diagram</i>
1.	<p>Raise the boom to approximately 40 degrees.</p> <p>Support and secure the boom using an A Frame or similar apparatus. It must support at least 2 tons.</p> <p>Apply the handbrake and insert chock under wheels.</p> <p>Release the blanking cap on the hydraulic tee.</p> <p>Removing the blanking cap will release the hydraulic pressure which may result in a spray of oil.</p> <p>Install the supplied pressure sensor and ensure it is tightly sealed.</p>	
2.	<p>Install the tee connector and pressure sensor into the rod of the main lift cylinder, where the flexible hose is connected to the solid hose on the chassis under the lift cylinder.</p> <p>Start the machine, pressurise the boom and check for leaks.</p>	 <p>View from under the main lift cylinder</p>



<i>Step</i>	<i>Description</i>	<i>Diagram</i>
3.	<p>Connect the supplied M12 4 metre cables (CB001026) into each of the pressure sensors.</p> <p>Cable tie the head pressure sensor cable to the flexible hydraulic hoses connected to the main lift cylinder. Make sure the cable isn't pinched or stretched when the boom is raised or lowered.</p> <p>Run the cables towards the cabin and cable tie with the other cables during External Cable Completion on page 33.</p> <p>Ensure the pressure sensors and cables do not collide with the boom and chassis structures and the cables do not stretch or pinch when the boom is raised and lowered.</p>	

Table 5: Pressure Manifold Installation



For further details on running the pressure sensor cables refer to the Installation Index on page 8

Compensation Pressure Sensors



Step	Description	Diagram
1.	<p>Release the cover behind the machine.</p> <p>Undo the hydraulic connection for the head compensation into flexible hydraulic line at the rear of the machine.</p> <p>Install the supplied tee piece and pressure sensor in line with the hydraulic connection.</p>	
2.	<p>Undo the hydraulic connection for the rod compensation into flexible hydraulic line at the rear of the machine.</p> <p>Install the supplied tee piece and pressure sensor in line with the hydraulic connection</p> <p>Start the machine, pressurise the boom and check for leaks.</p>	
3.	<p>Connect the supplied M12 4 metre cables (CB001026) into each of the pressure sensors.</p> <p>Add both cables to 2 m of snake tube.</p> <p>Run the snake tube and cables towards the cabin and cable tie with the other cables during External Cable Completion on page 33.</p> <p>Ensure the pressure sensors and cables do not collide with the boom and chassis structures and the cables do not stretch or pinch when the boom is raised and lowered.</p>	

Table 6: Compensation Pressure Sensor Installation



Angle the tee connections to ensure the hydraulic connections and pressure sensor do not hit the boom when the boom is lowered

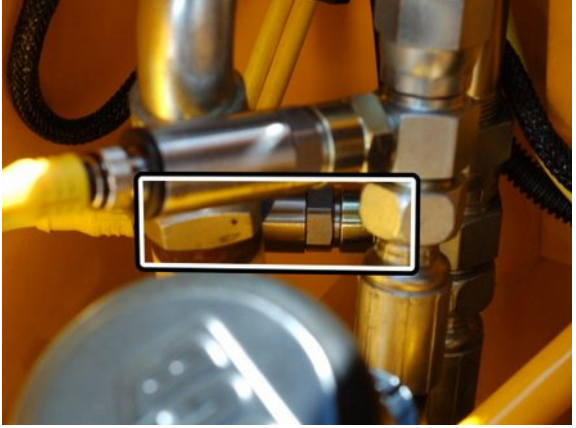

For further details on running the pressure sensor cables refer to the Installation Index on page 8

Reverse Camera

The rear camera video is displayed on the screen when the machine is in reverse gear to allow the operator to see behind the telehandler while reversing.

 Do not disconnect the camera power connection while the system is operating as this can damage the fuse.



Step	Description	Diagram
1.	<p>Drill a 31mm hole in the location shown. Making sure to leave enough room for a license plate</p> <p>Insert the camera through the hole and adjust the angle using the alignment washers.</p>	
2.	<p>Connect the camera power and signal connectors to the supplied 5m camera cable (CB001032).</p> <p>Note; The white connector is not used.</p> <p>Secure the camera cable to the license plate light cables</p> <p>Run the remainder of the cable towards the cabin and cable tie with the other cables during External Cable Completion on page 33.</p>	

Table 7: Reverse Camera Installation

 The camera's viewing angle may need to be adjusted once the system is installed and the display is operational.



For further details on running the camera cable refer to the Installation Index on page 8

Forward Camera

The forward camera video is displayed on the screen when the machine is in forward gear to allow the operator to see past the boom to obstructions that would damage the right front tyre.



Do not disconnect the camera power connection while the system is operating as this can damage the fuse.



<i>Step</i>	<i>Description</i>	<i>Diagram</i>
1.	<p>Mount the camera to the side mirror using the p-clips as shown.</p> <p>Secure using two M6 nuts.</p>	
2.	<p>Connect the camera power and signal connectors to the supplied 5m camera cable (CB001032).</p> <p>Note; The white connector is not used.</p> <p>Run the cable along the same path as the headlight cable, run it through the headlight post, then under the chassis to the side of the cabin.</p> <p>Cable tie with the light tower cable during External Cable Completion on page 33.</p>	

Table 8: Forward Camera Installation



The camera's viewing angle may need to be adjusted once the system is installed and the display is operational.



For further details on running the camera cable refer to the Installation Index on page 8

Light Tower Installation

The light tower warns other workers when the telehandler is lifting loads close to its maximum capacity.

<i>Step</i>	<i>Description</i>	<i>Diagram</i>
1.	<p>Drill and tap the holes required to mount the light tower bracket on the chassis according to the mounting diagram on page 26.</p> <p>Secure using the supplied bolts as described on page 26.</p> <p>Run the cable down the headlight post and through the hole for the headlight cable towards the cabin.</p> <p>Cable tie with the front camera cable during External Cable Completion on page 33.</p>	

Table 9: Light Tower Installation



For further details on running the light tower cable refer to the Installation Index on page 8

Light Tower Bracket Mounting Position

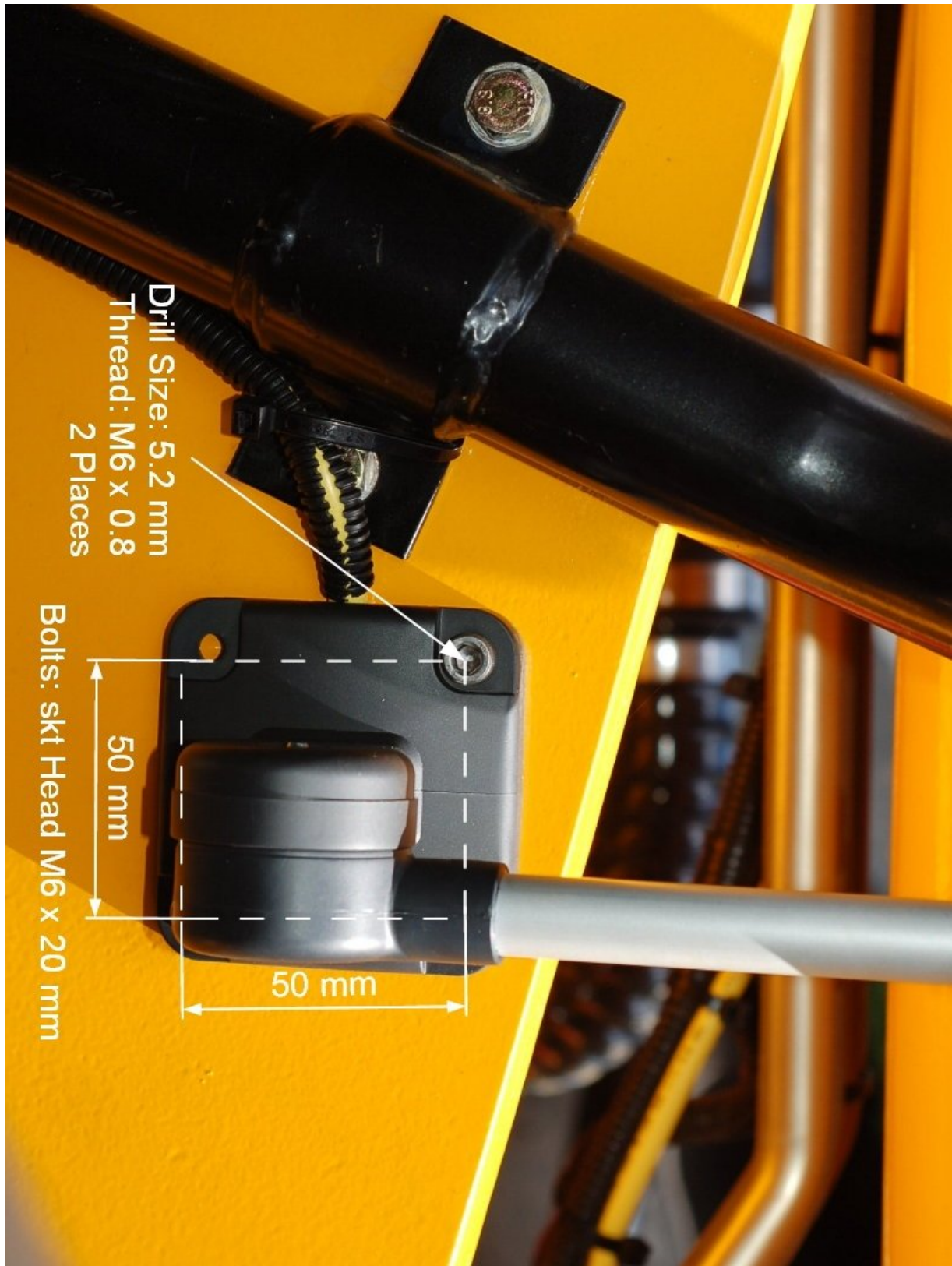

Illustration 4: Light Tower Bracket Mounting Position

Can Pressure Input Module (CPIM)

The CPIM is responsible for processing the information sent from the pressure sensors.



Accidentally swapping the pressure sensor connections will not damage system and can be determined if the display is showing a negative load.

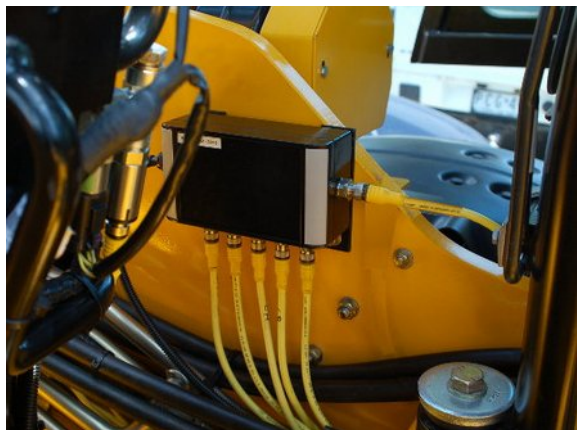
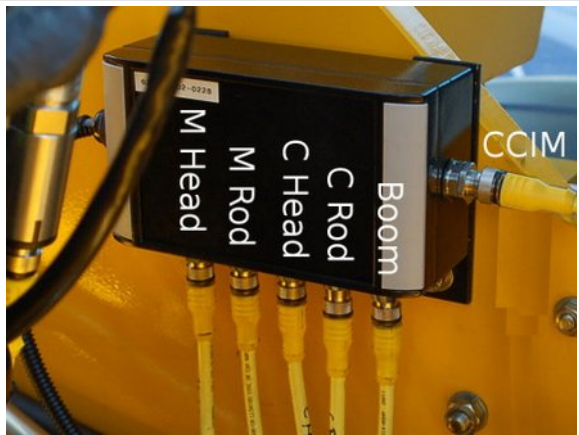

Do not plug the pressure sensor cable into the far right side boom cable. This will damage the system.

<i>Step</i>	<i>Description</i>	<i>Diagram</i>
1.	<p>Drill and tap two M8 holes for the CPIM bracket in the chassis behind the cabin.</p> <p>Mount using the supplied M8 x 12mm bolts and washers.</p>	
2.	<p>Connect the cables for the pressure sensors and boom cable to the CPIM according to the picture shown.</p> <p>Connect the supplied M12 4 metre cable (CB001026) into the connection out of the right side of the CPIM for the CCIM cable.</p> <p>Run the CCIM cable towards the cabin.</p>	



Step	Description	Diagram
3.	<p>Run the height limiter cable from out the left side of the CPIM to the hydraulic block beside the cabin.</p> <p>Connect the tee connector labelled “Raise” from the height limiter cable to boom raise (top left) connector on the hydraulic block and the tee connector labelled “Extend” from the height limiter cable to boom extend (down second from right) connector on the hydraulic block.</p> <p>Place a single cable tie to hold each cable position then disconnect the tee's from the raise and extend connectors, otherwise the boom will not move.</p> <p>Complete the cable installation during External Cable Completion on page 33.</p>	 <p>The diagram consists of two parts. The top part is a photograph of a hydraulic block with several hoses and connectors. Two specific connectors are circled in black. The bottom part is a schematic diagram of a blue hydraulic block with three circular connectors labeled 'Raise', 'Lower', and 'Extend'.</p>

Table 10: Can Pressure Input Module (CPIM) Installation

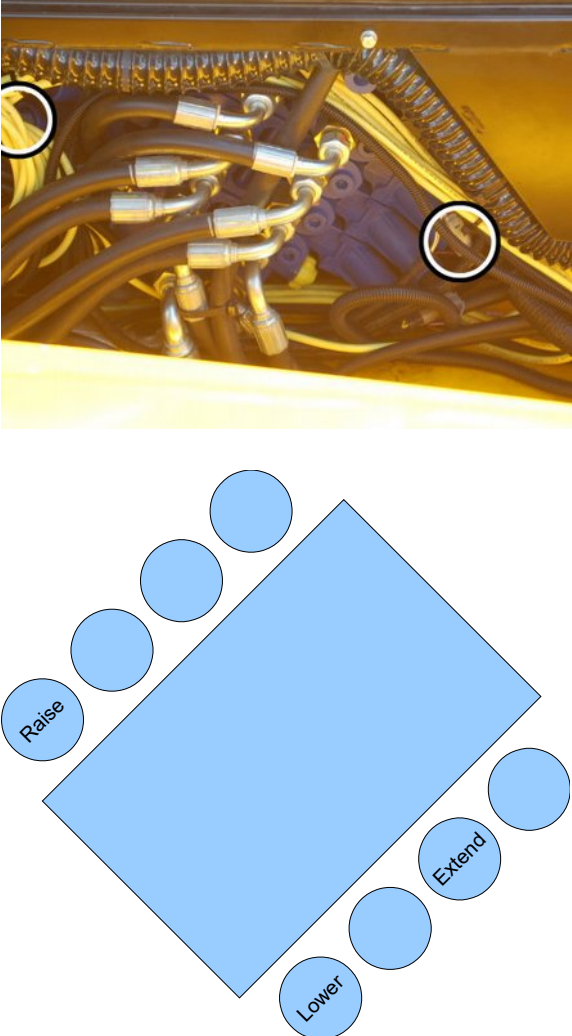

 For further details on running the cables refer to the Installation Index on page 8

Can Cabin Interface Module (CCIM)

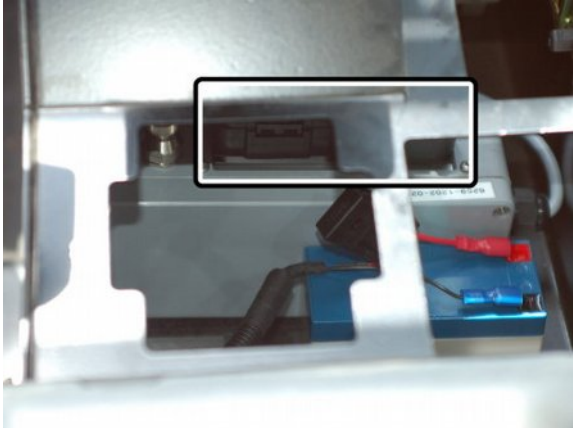
The CCIM connects the system into the machine electronics.

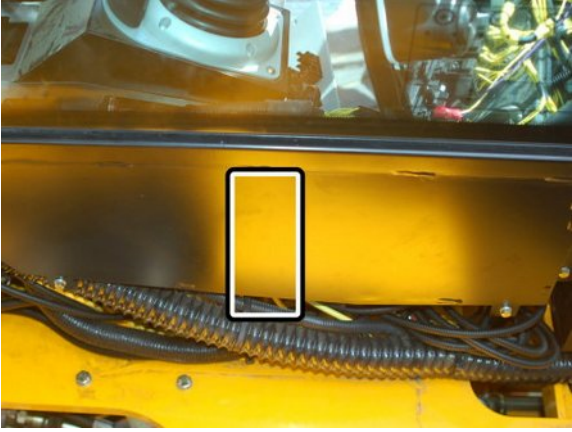
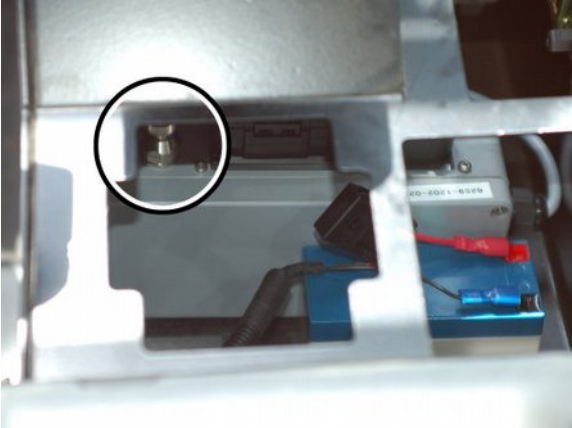
<i>Step</i>	<i>Description</i>	<i>Diagram</i>
<p>1.</p>	<p>Remove the connectors on the mounting plate beside the joystick inside the cabin, to allow access to the holes under the plate.</p> <p>Insert the backup battery through the hole under the plate.</p> <p>Position the backup battery (to the right of the CCIM) underneath the dashboard using double sided velcro tape. Note: Make sure to leave enough room for the CCIM.</p> <p>Position the CCIM to the left of the backup battery using double sided velcro tape.</p>	 <p>View from rear cabin window towards joystick</p>
<p>2.</p>	<p>Connect the Power/Camera harness and I/O harness to the bulkhead connectors on the CCIM.</p>	 <p>View from rear cabin window towards joystick</p>

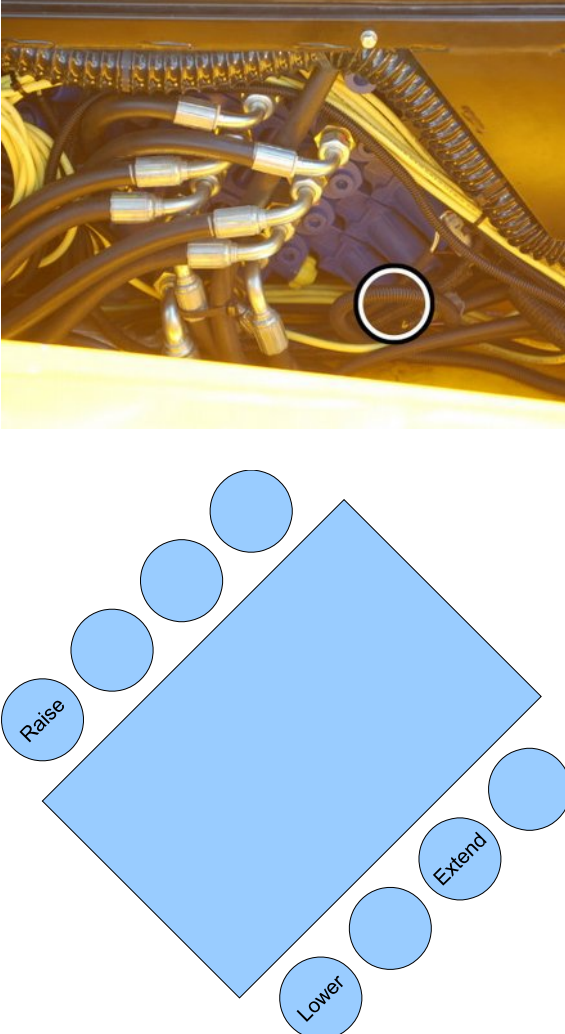
<i>Step</i>	<i>Description</i>	<i>Diagram</i>
3.	Pull the harnesses and the display cable from out the side of the CCIM through the hole down out to the chassis under the boom.	
4.	<p>From under the boom, pull the CCIM cable through the same hole into the cabin.</p> <p>Connect the CCIM cable to the 4 pin connector on the CCIM.</p>	 <p data-bbox="863 1093 1318 1169">View from rear cabin window towards joystick</p>

<i>Step</i>	<i>Description</i>	<i>Diagram</i>
5.	<p>Run the 2 pin tee connector on the I/O harness towards the hydraulic block beside the cabin.</p> <p>Connect the tee connector to the boom lower (bottom left) connector on the hydraulic block.</p> <p>Place a single cable tie to hold the cable position then disconnect the tee from the boom lower connector, otherwise the boom will not move.</p>	
6.	<p>Connect the camera power and signal cables from the front and rear cameras to the power/camera harness connectors.</p> <p>Note: The white connector is not used.</p>	





<i>Step</i>	<i>Description</i>	<i>Diagram</i>
7.	<p>Locate the 6 pin, 3 pin and 8 pin connectors from the I/O harness, Power/Camera harness and CCIM.</p> <p>Cut a small hole for the cables in the seal for the air conditioning adjustment running out from the dashboard to the chassis.</p> <p>Run each of the cables through the hole in the seal.</p> <p>Note: Pull the entire length of cable through into the cabin, excess cable will be stored under the dashboard cover in the cabin.</p> <p>Complete the cable installation during Dashboard Cables on page 37.</p>	

Table 11: CCIM Installation

 For further details on CCIM cables refer to the Installation Index on page 8

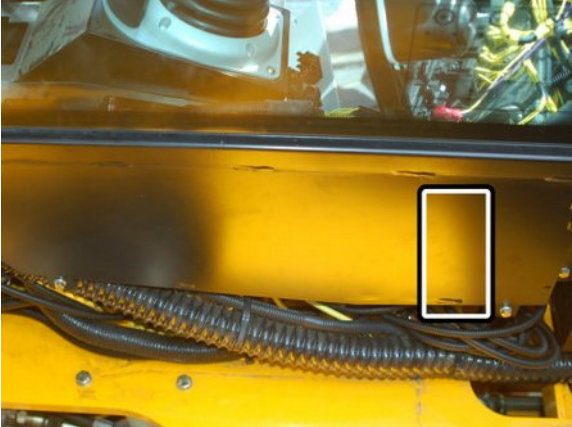
External Cable Completion

All external cabling is completed in this step.

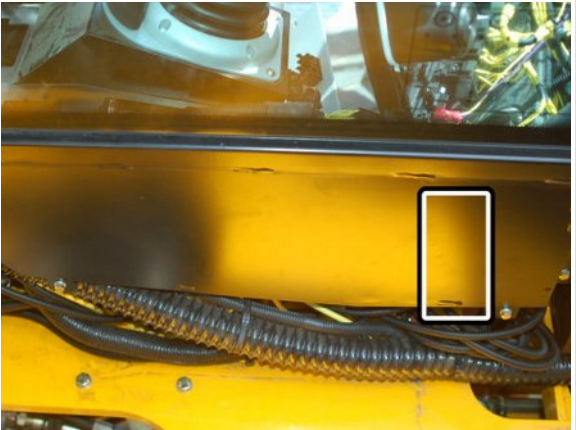
<i>Step</i>	<i>Description</i>	<i>Diagram</i>
1.	<p>Locate the reverse camera, boom and compensation pressure cables at the rear of the machine and cable tie to the existing snake tube and hydraulic lines running towards and underneath the cabin.</p> <p>Coil up any additional cable and store under the side panel beside the cabin.</p>	 <p>View from under the boom towards the rear of the machine</p>
2.	<p>At the front of the machine cable tie the front camera cable to the side of the cabin.</p> <p>Note: The old light tower is shown</p>	
3.	<p>Run the CCIM, signal light and camera cables through the hole into the cabin</p>	

<i>Step</i>	<i>Description</i>	<i>Diagram</i>
4.	<p>Secure all the cables from the CPIM and from out the holes into the cabin from the joystick and dashboard.</p> <p>Coil up any additional cable and store under the side panel beside the cabin.</p>	

Table 12: External Cable Completion

Dashboard Switches

The user control and override switch are installed in the dashboard.



<i>Step</i>	<i>Description</i>	<i>Diagram</i>
1.	Remove a blanking switch plate from the dashboard and install the override switch.	
2.	<p>Drill a 34 mm hole into the dashboard.</p> <p>Install the user control in the dashboard, aligned so the Enter cap is facing up.</p>	

Table 13: Dashboard Switches Installation

Display Installation

The display shows the current safety status of the telehandler.

<i>Step</i>	<i>Description</i>	<i>Diagram</i>
1.	<p>Position the display bracket in the top right of the dashboard in the approximate location shown.</p> <p>Drill two 7 mm holes to attach the bracket to the dashboard.</p> <p>Secure the bracket to the dashboard using the supplied large washers and nuts</p> <p>Attach the display to the bracket and tighten the grub screw</p>	

Table 14: Display Installation



Adjust the display bracket for optimal viewing angle once the display is powered



If the M12 screw lock connectors on the display are over tightened it will twist the connector pins attaching the connector to the PCB. See Appendix A: Attaching Display Connectors on page 48 for the correct method of attaching to the display connectors.

Dashboard Cables

The dashboard cables connects the display and the machine connections to the Gen 3 system.

Step	Description	Diagram
1.	<p>Run the 5 pin user control cable and the 8 pin cable from the CCIM through the gap between the window and the dashboard.</p> <p>Connect into the 5 and 8 pin connectors into the display.</p> <p>Insert the section of cable from the window to the display in snake tube.</p> <p>Coil up additional cable underneath the dashboard.</p>	
2.	<p>Pull the 3 pin connector through the dashboard under the steering wheel to the fuse/relay panel.</p>	

Table 15: Cabin Loom Installation



For further details on dashboard cables refer to the Installation Index on page 8

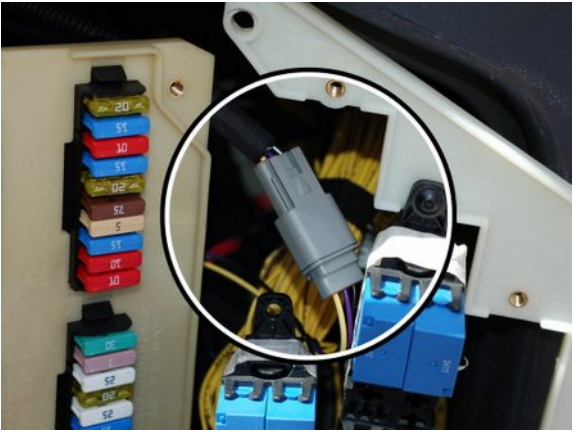

If the clip-on ferrites were removed from the CCIM and user control cables. See Appendix B: Reattach Ferrites and page 52 for the correct reattachment position.



If the M12 screw lock connectors on the display are over tightened it will twist the connector pins attaching the connector to the PCB. See Appendix A: Attaching Display Connectors on page 48 for the correct method of attaching to the display connectors.

Machine Connections

The following procedures connect the safety systems to the existing electronics in the machine.

Isolate the main battery before starting the machine connections

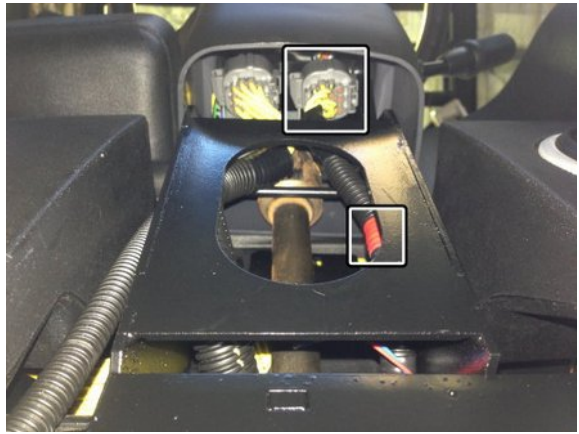
<i>Step</i>	<i>Description</i>	<i>Diagram</i>						
1.	Connect the spade terminals on the green and yellow wires from the machine input harness with the 4 and 12 pin connectors into the override switch mounted in the dashboard.							
2.	<p>Splice the following wire colours from the machine input harness with the 4 and 12 pin connectors into the connector for the left steering column switch (marked with red tape).</p> <p>Note: Remove the steering wheel height adjustment lever, to move the steering wheel higher, to get better access to the switch connector.</p> <table style="width: 100%; border-collapse: collapse;"> <thead> <tr> <th style="text-align: left; border-bottom: 1px solid black;">Wire Colour</th> <th style="text-align: left; border-bottom: 1px solid black;">Wire Number</th> </tr> </thead> <tbody> <tr> <td>Orange</td> <td>809</td> </tr> <tr> <td>Red</td> <td>808</td> </tr> </tbody> </table>	Wire Colour	Wire Number	Orange	809	Red	808	
Wire Colour	Wire Number							
Orange	809							
Red	808							

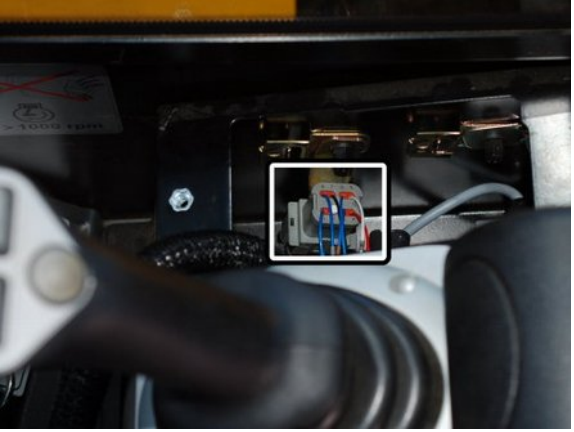
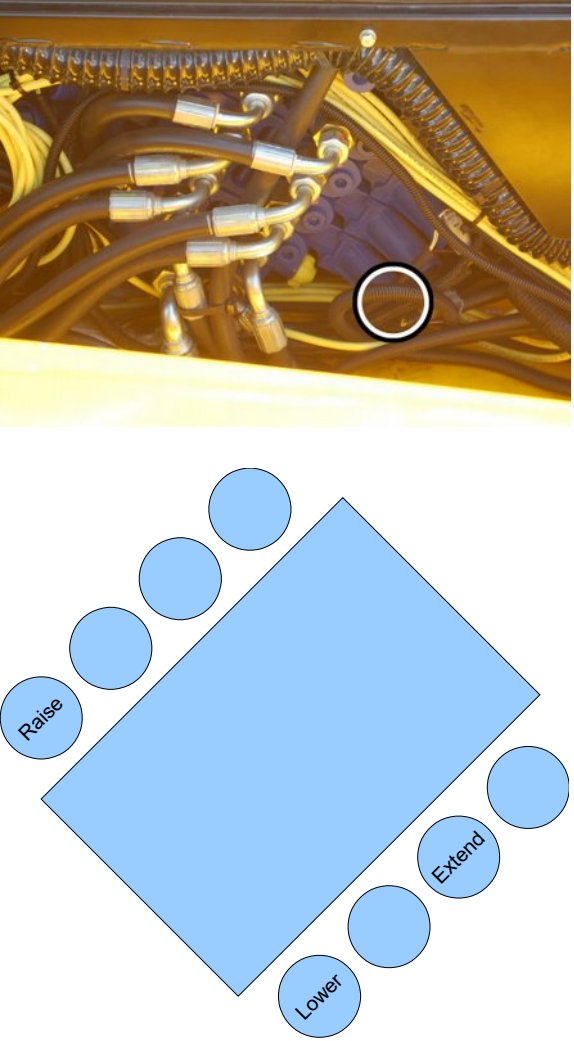
<i>Step</i>	<i>Description</i>	<i>Diagram</i>
3.	<p>Run the snake tube with the red and white wires on the machine input harness through the hole leading outside the cabin and then through the hole leading back inside the cabin underneath the joystick.</p> <p>Locate the 8 pin connector from the joystick and splice into the matching wire colours from the machine input harness.</p>	
4.	<p>Run the two 2 pin tee connectors on the machine cutout harness through the hole leading outside the cabin, to the hydraulic block located beside the cabin.</p> <p>Connect the tee connector to the boom lower (bottom right) connector on the hydraulic block.</p> <p>Place a single cable tie to hold the cable position then disconnect the tee from the boom lower connector, otherwise the boom will not move.</p>	



<i>Step</i>	<i>Description</i>	<i>Diagram</i>								
5.	<p>Attach the radio power harness to the radio connector.</p> <p>Note: If the radio connector is not installed in the machine. Cut off the tee connectors from the radio power harness and splice into the 4 pin radio power connector located under the dashboard according to the table below.</p> <table border="1" data-bbox="308 1003 831 1164"> <thead> <tr> <th><u>Wire Colour</u></th> <th><u>Wire Number</u></th> </tr> </thead> <tbody> <tr> <td>Black</td> <td>601AG</td> </tr> <tr> <td>Red</td> <td>181</td> </tr> <tr> <td>Yellow</td> <td>301F</td> </tr> </tbody> </table>	<u>Wire Colour</u>	<u>Wire Number</u>	Black	601AG	Red	181	Yellow	301F	
<u>Wire Colour</u>	<u>Wire Number</u>									
Black	601AG									
Red	181									
Yellow	301F									



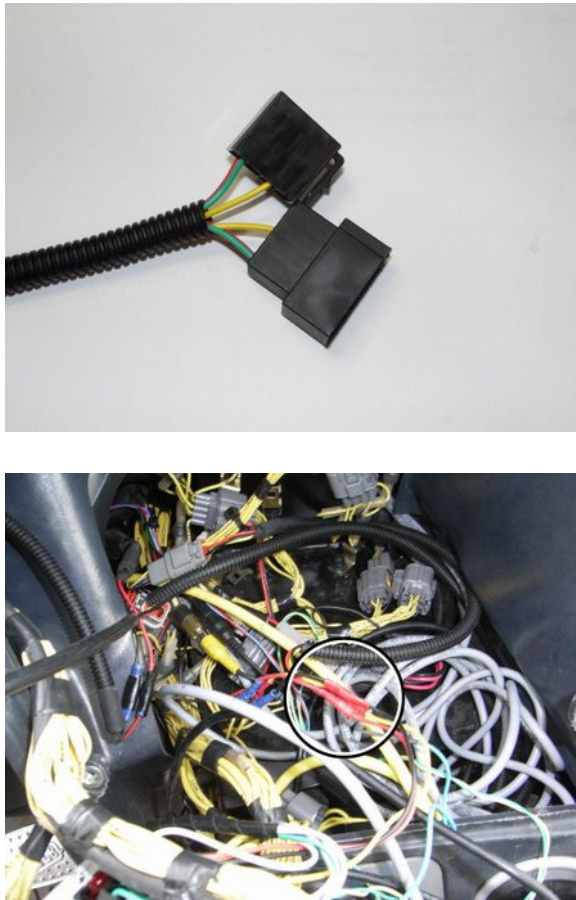

Table 16: Machine Connections

Finalisation

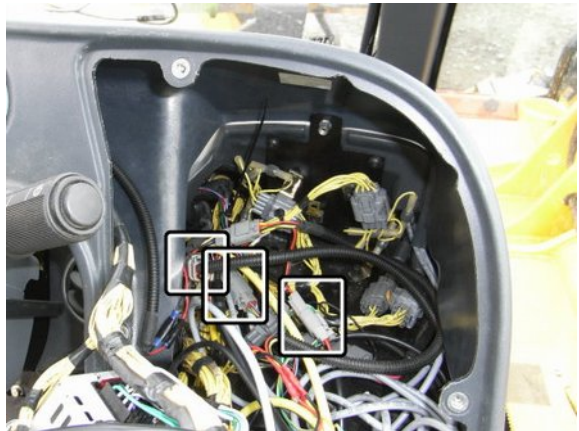
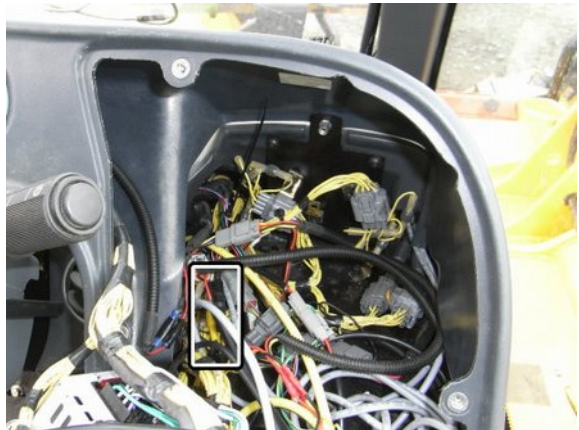
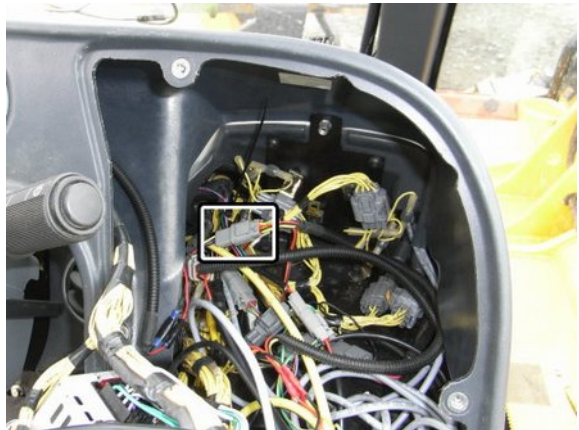
This section will complete the final power connections to power the system and finish any additional items.

 Do not disconnect the camera power connection while the system is operating as this can damage the fuse.

<i>Step</i>	<i>Description</i>	<i>Diagram</i>
1.	Connect the 4, 6 and 12 pin connectors from the machine input and cutout harnesses into the I/O harness.	
2.	Connect the camera power and signal cables from the front and rear cameras to the power/camera harness connectors. Note: The white connector is not used.	
3.	Connect the 3 pin connector from the radio power harness into the power/camera harness.	

<i>Step</i>	<i>Description</i>	<i>Diagram</i>
4.	<p>Connect the spade lug on the black wire to the negative (black) battery terminal.</p> <p>Connect the spade lug on the blue wire to the positive (red) battery terminal.</p>	
5.	Coil up the extra cables and store underneath the dashboard cover.	
6.	Reconnect the tee connectors back into the hydraulic block.	
7.	<p>Reconnect the main battery from the isolation switch.</p> <p>Turn the machine onto first stage /accessories and ensure the system is activated.</p>	



<i>Step</i>	<i>Description</i>	<i>Diagram</i>
8.	<p>Adjust the display bracket for optimal viewing</p> <p>Set the machine into forward gear to activate the forward camera. Adjust the forward camera so the front right wheel is visible.</p> <p>Set the machine into reverse gear to activate the reverse camera. Adjust the reverse camera so the video is level.</p>	
9.	<p>Operate the boom movement controls to test if a false N07 fault occurs.</p> <p>If a N07 fault does occur, adjust the arm on the stow switch forwards towards the stow switch trigger.</p> <p>Note: The actual switch arm orientation may differ from the picture.</p>	
10.	<p>Perform a final check on all the cabling and sensors.</p> <p>Replace all the covers</p>	

Table 17: Finalisation

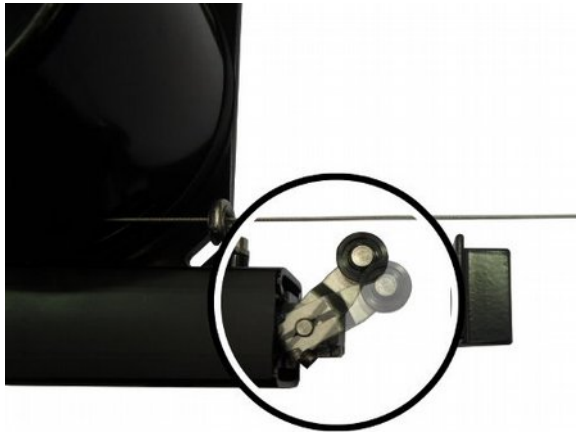

Complete the system checklist once installation has been completed.

Set Time & Sensor Calibration

Once the installation is complete, the time will need to be set and the sensors will require calibration.



A sensor calibration must be performed once the cable reeler and CPIM have been mounted. If the cable reeler or CPIM have been moved/repositioned a recalibration must be performed

<i>Step</i>	<i>Description</i>	<i>Diagram</i>
1.	<p>Press Enter on the user control dial to enter the menu system.</p> <p>Press the arrow buttons to select System Menu.</p> <p>Press Enter to select the menu.</p>	<hr/> <p>Main Menu</p> <hr/> <p>Attachment Selection Menu</p> <hr/> <p style="background-color: #ccccff; padding: 5px;">System Menu</p> <hr/> <p>Exit Menu</p> <hr/>
2.	<p>Select Advanced Menu</p>	<hr/> <p>System Menu</p> <hr/> <p>Volume / Brightness</p> <hr/> <p>Status Menu</p> <hr/> <p>Diagnostics Menu</p> <hr/> <p>System Tests</p> <hr/> <p style="background-color: #ccccff; padding: 5px;">Advanced Menu</p> <hr/> <p>Return to Main Menu</p> <hr/>

<i>Step</i>	<i>Description</i>	<i>Diagram</i>														
3.	Enter the password (Default Password: 2-8-4)	<table border="1"> <thead> <tr> <th colspan="2">Enter Password</th> </tr> </thead> <tbody> <tr> <td>Number 1</td> <td>2</td> </tr> <tr> <td>Number 2</td> <td>8</td> </tr> <tr> <td>Number 3</td> <td>4</td> </tr> <tr> <td colspan="2">Submit Password</td> </tr> <tr> <td colspan="2">Return to System Menu</td> </tr> </tbody> </table>	Enter Password		Number 1	2	Number 2	8	Number 3	4	Submit Password		Return to System Menu			
Enter Password																
Number 1	2															
Number 2	8															
Number 3	4															
Submit Password																
Return to System Menu																
4.	Select Set Time / Date	<table border="1"> <thead> <tr> <th colspan="2">Advanced Settings</th> </tr> </thead> <tbody> <tr> <td colspan="2">Set Time / Date</td> </tr> <tr> <td colspan="2">Sensor Calibrations</td> </tr> <tr> <td colspan="2">Change Language</td> </tr> <tr> <td colspan="2">Change Password</td> </tr> <tr> <td colspan="2">Return to System Menu</td> </tr> </tbody> </table>	Advanced Settings		Set Time / Date		Sensor Calibrations		Change Language		Change Password		Return to System Menu			
Advanced Settings																
Set Time / Date																
Sensor Calibrations																
Change Language																
Change Password																
Return to System Menu																
5.	<p>Enter the correct time and date for your area.</p> <p>Press the arrow keys to select a time/date parameter</p> <p>Press Enter and the parameter will change to red, press the arrow keys to change the value and then press the Enter key to store the value.</p> <p>Note: The hour parameter is in 24 hour clock</p> <p>Repeat for the rest of the time values</p>	<table border="1"> <thead> <tr> <th colspan="2">Set Time / Date</th> </tr> </thead> <tbody> <tr> <td>Hour</td> <td>15</td> </tr> <tr> <td>Minute</td> <td>54</td> </tr> <tr> <td>Day</td> <td>10</td> </tr> <tr> <td>Month</td> <td>2</td> </tr> <tr> <td>Year</td> <td>2016</td> </tr> <tr> <td>Region</td> <td>Melbourne</td> </tr> </tbody> </table>	Set Time / Date		Hour	15	Minute	54	Day	10	Month	2	Year	2016	Region	Melbourne
Set Time / Date																
Hour	15															
Minute	54															
Day	10															
Month	2															
Year	2016															
Region	Melbourne															

<i>Step</i>	<i>Description</i>	<i>Diagram</i>
6.	Scroll to the next page and select Save to store the new time/date and return to the Advanced Menu.	<p>The diagram shows a menu with a blue header bar containing the text "Save". Below the header bar is a white bar containing the text "Return to Advanced Menu".</p>
7.	Select Sensor Calibrations	<p>The diagram shows a menu titled "Advanced Settings" at the top. Below the title are five menu items: "Set Time / Date", "Sensor Calibrations" (highlighted in blue), "Change Language", "Change Password", and "Return to System Menu".</p>
8.	Select Calibrate Carrier Angle and then follow the instructions on the screen to complete the calibration. Repeat for Calibrate Boom Angle and Calibrate Boom Length.	<p>The diagram shows a menu titled "Sensor Calibration Menu" at the top. Below the title are four menu items: "Calibrate Carrier Angle" (highlighted in blue), "Calibrate Boom Angle", "Calibrate Boom Length", and "Return to Advanced Menu".</p>

Table 18: Sensor Calibration

Appendix A: Attaching Display Connectors

The procedure below describes the correct method of attaching the cables to the screw lock connectors on the display.



If the M12 screw lock connectors on the display are over tightened, it will twist the connector pins attaching the connector to the PCB.

<i>Step</i>	<i>Description</i>	<i>Diagram</i>
1.	<p>Connect the cable from the user control to the top 5 pin connector on the display.</p> <p>Connect the cable from the CCIM to the bottom 8 pin connector on the display.</p>	
2.	<p>Line up the alignment hole on the cable connector with the alignment notch on the display connector.</p>	



<i>Step</i>	<i>Description</i>	<i>Diagram</i>
3.	Push the female connector from the cable into the male connector on the display.	
4.	Rotate the nut on the female connector by hand in a clockwise direction, until the tension on the nut starts to increase.	
5.	Push the cable in again and repeat steps 3 and 4 until the connector is secure.	

Table 19: Install Display Connector Procedure



The method to correctly secure the cable is to push-twist-push-twist until the connector is fully inserted and secure. This will minimise the twisting force applied to the connector.

Below is a picture of a damaged connector on the PCB inside the display. This damaged occurred because the connector was over tightened.

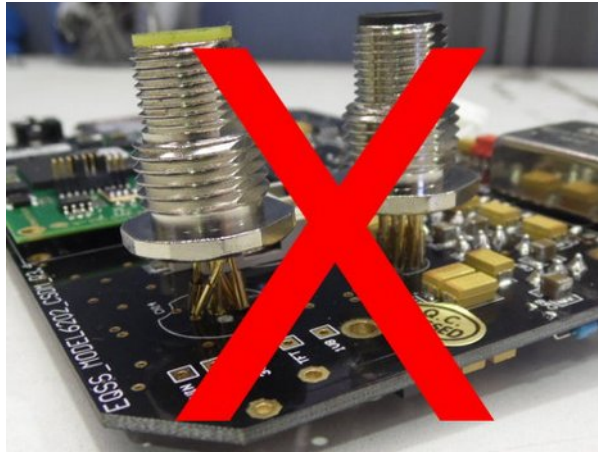

Illustration 5: Damaged Display Connector



Do not use any tools to tighten the connector.



Illustration 6: Do Not Use Tools To Tighten Connector



Do not over-tighten the nuts on the back of the display connectors. These nuts should only be hand tightened. If the nuts are overtightened it will damage the PCB inside the display.



Illustration 7: Do Not Over Tighten Nuts



Damage to the display connectors is not covered under warranty.

Appendix B: Reattach Ferrites

If the clip-on ferrites on the displays are removed during installation, they will need to be reattached as shown in the procedure below.

 If the ferrites are not reinstalled or attached in the specified location the Gen3-LMS kit will not meet the AS/NZS CISPR 22:2006 certification.

<i>Step</i>	<i>Description</i>	<i>Diagram</i>
1.	<p>Attach the two clip-on ferrites at a location of 60 mm and 260 mm from the start of the connector to the start of the ferrite.</p> <p>Do this for both the CCIM and user control cables that plug into the display.</p>	

Table 20: Reattach Ferrites Procedure

Indexes and Tables

Illustration Index

Illustration 1: Machine Boom.....	10
Illustration 2: Machine Chassis.....	11
Illustration 3: Cable Reeler Mounting Position.....	16
Illustration 4: Light Tower Bracket Mounting Position.....	26
Illustration 5: Damaged Display Connector.....	50
Illustration 6: Do Not Use Tools To Tighten Connector.....	50
Illustration 7: Do Not Over Tighten Nuts.....	51

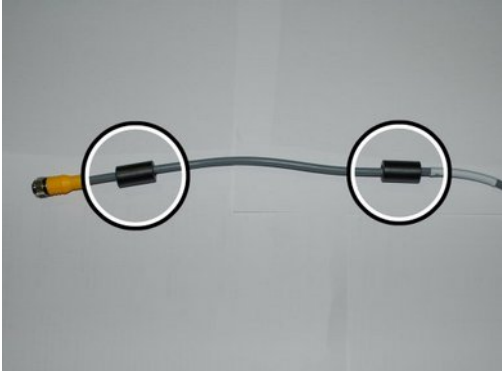
Index of Tables

Table 1: Component Installation Index.....	8
Table 2: Cable Installation Index.....	9
Table 3: Cover removal.....	13
Table 4: Cable Reeler Installation.....	15
Table 5: Pressure Manifold Installation.....	18
Table 6: Compensation Pressure Sensor Installation.....	20
Table 7: Reverse Camera Installation.....	21
Table 8: Forward Camera Installation.....	23
Table 9: Light Tower Installation.....	25
Table 10: Can Pressure Input Module (CPIM) Installation.....	28
Table 11: CCIM Installation.....	32
Table 12: External Cable Completion.....	34
Table 13: Dashboard Switches Installation.....	35
Table 14: Display Installation.....	36
Table 15: Cabin Loom Installation.....	37
Table 16: Machine Connections.....	41
Table 17: Finalisation.....	44
Table 18: Sensor Calibration.....	47
Table 19: Install Display Connector Procedure.....	49
Table 20: Reattach Ferrites Procedure.....	52

Equipment Safety Systems Pty. Ltd. ABN: 31 061 789 151
27 Cumberland Drive, Seaford 3198, Victoria, Australia

Tel: +61 3 8770 6555
Fax: +61 3 8770 6590
Web: www.eqss.com.au