



# eqss™ Gen-3 LMS Telehandler Load Management System

## Installation Manual for HTL7210



### **PLEASE NOTE:**

**\*\*\*Do Not Swap Components between Gen3-LMS kits\*\*\***  
**When installing multiple Gen3-LMS kits, make sure the serial number on the sticker matches the serial number on the machine.**

**\*\*\*Failure To Follow Installation Manual Will Void Warranty\*\*\***

## Documentation Conventions

The list below highlights important documentation conventions.



Text presented in this manner is intended to provide the user with some general information. The user should ensure information presented in this manner is clearly understood.



Text presented in this manner provides the user with information to assist in completion of the current procedure being explained.



Text presented in this manner indicates that a failure to follow directions could result in damage to equipment, loss of information, bodily harm, or loss of life.

## **Important Information**

Information contained in this publication regarding this device's applications and the like is provided only for your convenience and may be superseded by updates. It is your responsibility to ensure that the application or our equipment meets with your specifications.

EQUIPMENT SAFETY SYSTEMS MAKE NO REPRESENTATIONS OR WARRANTIES OF ANY KIND WHETHER EXPRESS OR IMPLIED, WRITTEN OR ORAL, STATUTORY OR OTHERWISE, RELATED TO THE INFORMATION, INCLUDING BUT NOT LIMITED TO, IT'S CONDITION, QUALITY, PERFORMANCE, MERCHANTABILITY OR FITNESS FOR PURPOSE.

Equipment Safety Systems disclaims all liability arising from this information and its use. Use of Equipment Safety Systems' products as critical components in life support systems is not authorised except with express written approval by Equipment Safety Systems. No licenses are conveyed, implicitly or otherwise, under any Equipment Safety Systems intellectual property rights.

# Table of Contents

Tools Required for Installation.....	6
Installation Index.....	7
Covers.....	10
Cable Reeler Installation.....	13
Cable Reeler Mounting Position.....	15
Pressure Sensor Installation.....	16
Pressure Manifold.....	16
Compensation Pressure Sensors.....	19
Reverse Camera.....	21
Forward Camera.....	23
Signal Light Installation.....	25
Can Pressure Input Module (CPIM).....	27
External Cable Completion.....	28
Display Installation.....	30
User Input Control.....	31
Can Cabin Interface Module (CCIM).....	32
Machine Connections.....	34
Cabin Loom.....	36
Finalisation.....	39
Set Time & Sensor Calibration.....	42
Schematics.....	45
Appendix A: Attaching Display Connectors.....	48
Appendix B: Reattach Ferrites.....	52

Indexes and Tables.....53

# Tools Required for Installation

The tools required to perform the installation of the TSS are listed below

- Pencil or Texta
- Drill
- Drill bits
  - 3.3 mm
  - 4.5 mm
  - 5 mm
  - 6.8 mm
  - 8.5 mm
- Centre punch
- Tap T-Handle
- Taps
  - M6
  - M8
- Drill and tap oil
- Metric Allen keys
- Phillips Head screw driver
- Spanners and sockets
  - 7 mm
  - 10 mm
  - 13 mm
- Loctite thread locker
- Side cutters
- Stanley knife
- Crimpers
- Wire strippers
- Torque Wrench

# Installation Index

The components and cables of the Gen-3 Telehandler Load Management System are outline in the tables below. The following pages show where the components are installed and the cable routing.

See the appropriate manual section for a detailed installation description for each component.



Refer to this section for any component placement or cable routing issues

<i>Item</i>	<i>Component Description</i>
1	Cable Reeler
2	Main Lift Cylinder Pressure Sensors
3	Compensation Cylinder Pressure Sensors
4	Can Pressure Input Module (CPIM)
5	Cutout Connection
6	Forward Camera
7	Signal Light
8	Rear Camera

Table 1: Component Installation Index

<i>Colour</i>	<i>Cable Description</i>
Light Purple	Boom Cable
Dark Green	Main Cylinder Pressure Sensor Cables
Dark Blue	Compensation Cylinder Pressure Sensors Cables
Red	Cutout Harness
Light Green	Forward Camera Cable
Brown	Signal Light Cable
Light Blue	Rear Camera Cable
Dark Purple	CCIM Cable

Table 2: Cable Installation Index



*Illustration 1: Machine Boom*



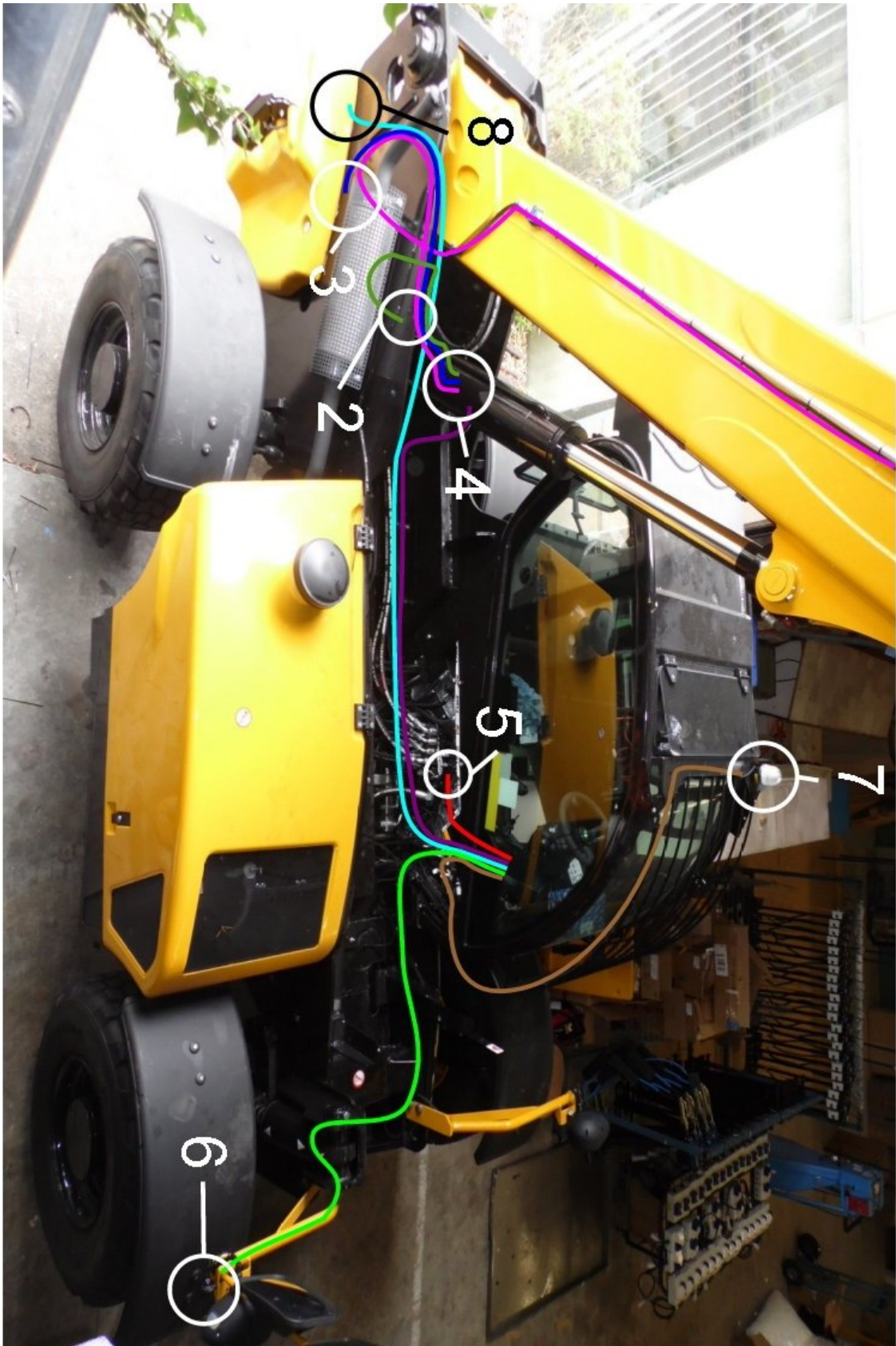

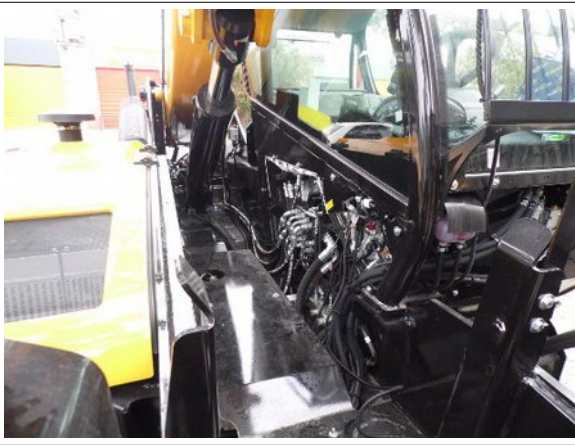





Illustration 2: Machine Chassis

# Covers

Remove the following covers before starting the installation

<i>Step</i>	<i>Description</i>	<i>Diagram</i>
1.	Remove the rear cover and disconnect the license plate light.	
2.	Remove the side panel next to the cabin under the boom.	
3.	Remove the panel in front of the cabin behind the front left wheel	



<i>Step</i>	<i>Description</i>	<i>Diagram</i>
4.	Inside the cabin remove the fuse panel cover on the side of the dashboard.	
5.	Remove the cover under the steering wheel.	
6.	Undo the bolts attaching the dashboard and remove the radio insert.	

<i>Step</i>	<i>Description</i>	<i>Diagram</i>
7.	Remove the cover over the dashboard display.	

*Table 3: Cover removal*

# Cable Reeler Installation

The cable reeler is used to measure the boom extension to determine the maximum lifting capacity.



A false N07 fault can occur if the boom jumps off the stow switch due to pressurising the hydraulic system and without operating the boom extension control. Ensure the stow switch arm is correctly adjusted to prevent this error.

<i>Step</i>	<i>Description</i>	<i>Diagram</i>
1.	<p>Drill and tap the holes for the cable reeler according to the mounting diagram on page 15.</p> <p>Mount using the supplied M6 x 12 mm bolts and washers.</p>	
2.	<p>Drill and tap an M8 hole for the cable anchor. Ensure the cable anchor is positioned so the cable runs in line with the boom.</p> <p>Mount the cable anchor and attach the cable.</p>	
3.	<p>Drill and tap the M6 holes for the stow switch trigger bracket.</p> <p>Mount the stow switch trigger bracket using the supplied M6 x 12 mm bolts and washers.</p> <p>Adjust the stow switch arm to ensure the stow switch is pressed when the boom is retracted.</p>	



<i>Step</i>	<i>Description</i>	<i>Diagram</i>
4.	Connect the supplied M12 10 metre cable (CB001027) into the cable reeler connection.	
5.	<p>Run the cable under the existing protective plate for the limit switch and then secure with cable ties down the protective pipe for the limit switch cable down to the base of the boom.</p> <p>Cable tie to the flexible hydraulic hoses down to the chassis. Make sure the cable isn't pinched or stretched when the boom is raised or lowered.</p> <p>Run the remainder of the cable and connect into the CPIM during External Cable Completion on page 28.</p>	

Table 4: Cable Reeler Installation



For further details on running the boom cable refer to the Installation Index on page 7



# Cable Reeler Mounting Position



Illustration 3: Cable Reeler Mounting Position

# Pressure Sensor Installation

The hydraulic pressure sensors are used to measure the lifting load of the telehandler.

## Pressure Manifold



Failure to tighten the bolts to the correct torque on the pressure manifold may result in a pressure failure on the counterbalance valve causing an uncontrolled fall of the boom.

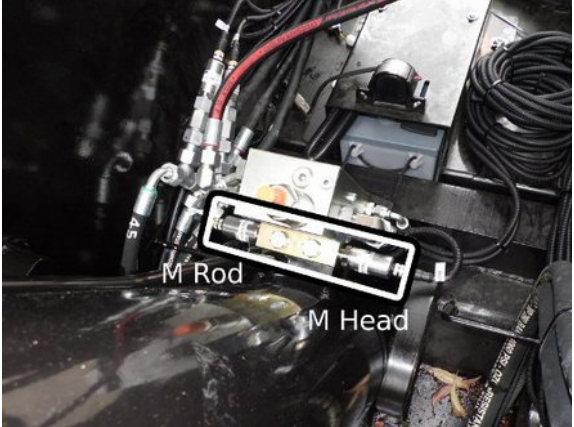

<i>Step</i>	<i>Description</i>	<i>Diagram</i>
1.	<p>Raise the boom to approximately 40 degrees.</p> <p>Support and secure the boom using an A Frame or similar apparatus. <b>It must support at least 2 tons.</b></p> <p>Apply the handbrake and insert chock under wheels.</p> <p>Remove the counterbalance valve on the side of the hydraulic lifting ram.</p> <p><b>Removing the counterbalance valve will release the hydraulic pressure which may result in a spray of oil.</b></p> <p>Place the pressure manifold between the existing counterbalance valve manifold and the cylinder, it might be necessary to adjust the angle of the elbows into the A and B ports to ensure they don't hit the pressure sensors</p> <p>Secure the pressure manifold using the supplied bolts and seals. Tighten the <b>12.9 grade</b> bolts for the manifold to <b>41 NM</b> using a torque wrench.</p> <p><b>Start the machine, pressurise the boom and check for leaks.</b></p>	 <p>View from top of main cylinder towards the chassis</p>

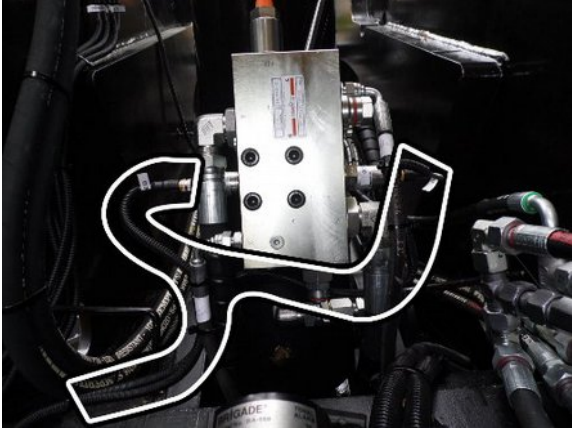
<i>Step</i>	<i>Description</i>	<i>Diagram</i>
2.	<p>Connect the supplied M12 4 metre cables (CB001026) into each of the pressure sensors.</p> <p>Cable tie to the flexible hydraulic hoses connected to the main lift cylinder. Make sure the cable isn't pinched or stretched when the boom is raised or lowered.</p> <p>Cable tie with the other cables during External Cable Completion on page 28.</p>	

*Table 5: Pressure Manifold Installation*



For further details on running the pressure sensor cables refer to the Installation Index on page 7

# Compensation Pressure Sensors



Step	Description	Diagram
1.	Undo the hydraulic connections for the compensation cylinder at the location when the hoses from the compensation cylinder tee into the hydraulic lines at the rear of the machine.	 <p data-bbox="863 757 1398 786">View from the rear of the machine</p>
2.	Install the supplied tee pieces and pressure sensors on the tee of the existing hydraulic connections.  <b>Start the machine, pressurise the boom and check for leaks.</b>	
3.	Connect the supplied M12 4 metre cables (CB001026) into each of the pressure sensors.  Cable tie with the other cables during External Cable Completion on page 28.	

Table 6: Compensation Pressure Sensor Installation



Angle the tee connections to ensure the hydraulic connections and pressure sensor do not hit the boom when the boom is lowered

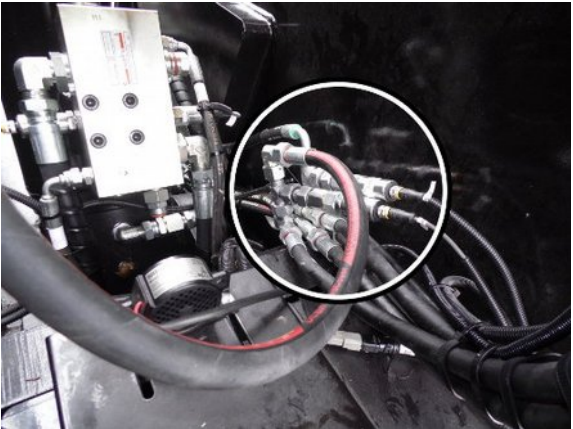
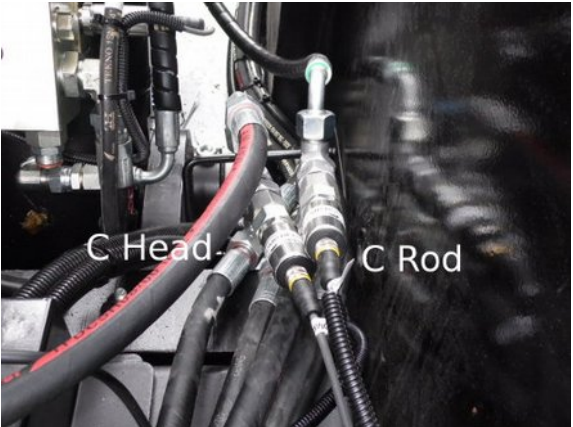

For further details on running the pressure sensor cables refer to the Installation Index on page 7

# Reverse Camera

The rear camera video is displayed on the screen when the machine is in reverse gear to allow the operator to see behind the telehandler while reversing.

 Do not disconnect the camera power connection while the system is operating as this can damage the fuse.



Step	Description	Diagram
1.	<p>Drill a 31mm hole in the location shown in the rear cover. Making sure to leave enough room for a license plate</p> <p>Insert the camera through the hole and adjust the angle using the alignment washers.</p>	
2.	<p>Connect the camera power and signal connectors to the supplied 5m camera cable (CB001032).</p> <p>Note; The white connector is not used.</p> <p>Run the remainder of the cable towards the cabin and insert into cabin during External Cable Completion on page 28.</p>	

Table 7: Reverse Camera Installation

 The camera's viewing angle may need to be adjusted once the system is installed and the display is operational.



Once the cable has been tied to the license plate light cable disconnect the cable to remove the rear cover until the installation is finalised



For further details on running the camera cable refer to the Installation Index on page 7



# Forward Camera

The forward camera video is displayed on the screen when the machine is in forward gear to allow the operator to see past the boom to obstructions that would damage the right front tyre.



Do not disconnect the camera power connection while the system is operating as this can damage the fuse.

<i>Step</i>	<i>Description</i>	<i>Diagram</i>
1.	<p>Drill two 7 mm holes spaced 25 mm apart on the side of the right headlight post to mount the camera.</p> <p>Mount the camera to the side of the right headlight post and secure using the supplied nuts.</p>	
2.	<p>Connect the camera power and signal connectors to the supplied 5m camera cable (CB001032).</p> <p>Note; The white connector is not used.</p> <p>Run the cable along the same path as the headlight cable through the headlight post.</p> <p>Run the remainder of the cable towards the cabin following the headlight cable and insert into cabin during External Cable Completion on page 28.</p>	

Table 8: Forward Camera Installation



The camera's viewing angle may need to be adjusted once the system is installed and the display is operational.



For further details on running the camera cable refer to the Installation Index on page 7



# Signal Light Installation

The signal light warns other workers when the telehandler is lifting loads close to its maximum capacity.



Ensure the power supply voltage is greater than 13.5V otherwise the signal light may not illuminate correctly.

<i>Step</i>	<i>Description</i>	<i>Diagram</i>
1.	Mount the signal light to the top of the front windshield guard on the side cabin closest to the door.	
2.	Run the cable towards the chassis and down the side of the windshield and cable tie to the windshield guard bar down towards the chassis.	

<i>Step</i>	<i>Description</i>	<i>Diagram</i>
3.	File a 10 mm hole in the plastic front cover to fit the signal light cable	

*Table 9: Signal Light Installation*

# Can Pressure Input Module (CPIM)

The CPIM is responsible for processing the information send from the pressure sensors.



Accidentally swapping the pressure sensor connections will not damage the system.



Do not plug the pressure sensor cable into the far right side boom cable. This will damage the system.





Step	Description	Diagram
1.	<p>Raise the boom to the maximum height to more easily access the area for mounting the CPIM.</p> <p>Drill and tap two M8 holes for the CPIM bracket in the side of the chassis.</p> <p>Mount using the supplied M8 x 12mm bolts and washers.</p>	
2.	<p>Connect the cables for the pressure sensors, boom cable and signal light to the CPIM according to the picture shown.</p> <p>Note: The CCIM cable will be installed during External Cable Completion on page 28.</p>	



Table 10: Can Pressure Input Module (CPIM) Installation

# External Cable Completion

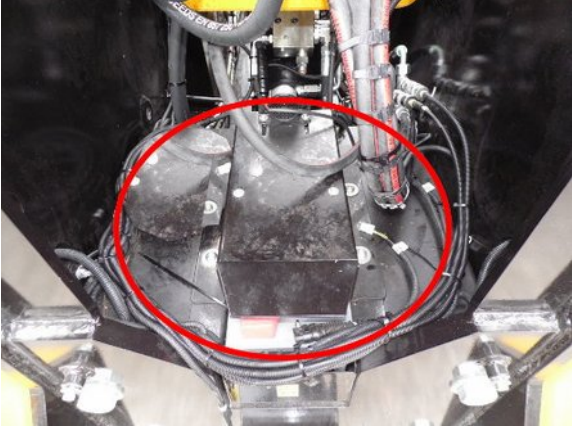
All external cabling is completed in this step.

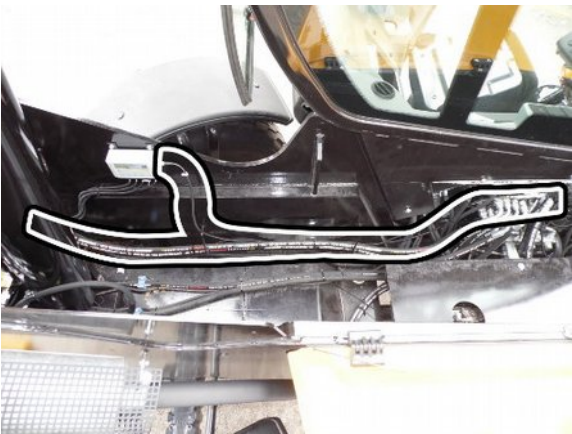
<i>Step</i>	<i>Description</i>	<i>Diagram</i>
1.	Coil up the additional cabling for the pressure sensor and boom cables in a large loop around the battery cover at the rear of the machine as shown by the red line, to reduce bundling.	 <p>View from behind the machine</p>
2.	Connect the supplied M12 4 metre cable (CB001026) into the right side of the CPIM for the CCIM cable.	
3.	Run the CCIM and reverse camera cables along the side of the chassis towards the cabin.	



<i>Step</i>	<i>Description</i>	<i>Diagram</i>
4.	At the front of the machine cable tie the signal light and forward camera together and run towards the cabin.	
5.	<p>Run the CCIM, signal light and camera cables up through the hole into the cabin under the dashboard.</p> <p>Note: Pull a short length of cable through into the cabin. Store excess cable under the hole into the dashboard.</p>	

*Table 11: External Cable Completion*

# Display Installation

The display shows the current safety status of the telehandler.

<i>Step</i>	<i>Description</i>	<i>Diagram</i>
1.	<p>Attach the shaft of the display bracket to the existing hole in the crush protection frame in the top right corner and secure using the supplied washer and nut.</p> <p>Attach the display to the bracket and tighten the grub screw.</p>	

Table 12: Display Installation



Adjust the display bracket for optimal viewing angle once the display is powered



If the M12 screw lock connectors on the display are over tightened it will twist the connector pins attaching the connector to the PCB. See Appendix A: Attaching Display Connectors on page 48 for the correct method of attaching to the display connectors.

# User Input Control

The user input control consists of a single dial switch mounted in the dashboard.

<i>Step</i>	<i>Description</i>	<i>Diagram</i>
1.	Drill a 34 mm hole into the dashboard.  Install the user input control dial in the dashboard, aligned so the Enter cap is facing up.	

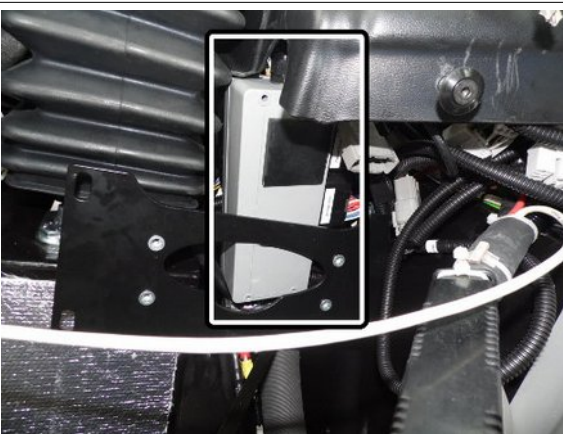

Table 13: User Input Control Installation



If the M12 screw lock connectors on the display are over tightened it will twist the connector pins attaching the connector to the PCB. See Appendix A: Attaching Display Connectors on page 48 for the correct method of attaching to the display connectors.

# Can Cabin Interface Module (CCIM)

The CCIM connects the system into the machine electronics.

<i>Step</i>	<i>Description</i>	<i>Diagram</i>
1.	Remove the bolts securing the ECU module under the steering wheel for easier mounting of the CCIM module.	 <p data-bbox="863 882 1417 913">View from cabin floor towards dash</p>
2.	<p data-bbox="272 936 815 1178">Position the CCIM to mount behind the bracket securing the ECU and ensure it is resting against the side of the steering wheel shaft rubber and doesn't interfere with the foot pedals.</p> <p data-bbox="272 1227 815 1303">Once positioned correctly secure in place using the velcro tape.</p> <p data-bbox="272 1352 815 1552">Once the velcro tape has been placed, remove the CCIM for easier access to the machine connections. Reattach to the velcro in the section Finalisation on page 39.</p>	 <p data-bbox="863 1359 1417 1391">View from cabin floor towards dash</p>
3.	Secure the backup battery to the velcro on the top of the CCIM	





<i>Step</i>	<i>Description</i>	<i>Diagram</i>

Table 14: CCIM Installation

# Machine Connections

The following procedures connect the safety systems to the existing electronics in the machine.

 Isolate the main battery before starting the machine connections

 After completing the machine connections the boom can not be moved until the installation is complete

 Crimp joiners have been supplied to complete the machine connections. Alternatively the connections can be completed using solder and heat shrink if the skills, material and equipment is available to the installer.

<i>Step</i>	<i>Description</i>	<i>Diagram</i>
1.	<p>On the side of the cabin underneath the boom locate the X268.1 connector going into the base of the joystick.</p> <p>Connect the 12 pin tee connection on the machine cutout harness into the X268.1 connector.</p> <p>Run the 6 pin connector on the other side of the machine cutout harness, through the hole into the cabin.</p>	



Step	Description	Diagram
2.	<p>Locate the override switch terminal X146 in the removable dashboard panel.</p> <p>Remove the fork terminal connected to wire 6038 from the override switch and replace with the fork terminal on the violet wire from the machine input harness.</p> <p>Cut off the fork terminal on the wire 6038 and join to the yellow wire from the machine input harness.</p>	
3.	<p>Locate the connector from the left column switch X137 towards the base of the steering wheel shaft.</p> <p>Connect the 6 pin tee connection on the machine input harness into the X137 connector.</p>	 <p data-bbox="858 1283 1439 1323">View through dashboard panel hole</p>
4.	<p>Connect the radio power harness into the radio power connector X151.</p>	



Table 15: Machine Connections

# Cabin Loom

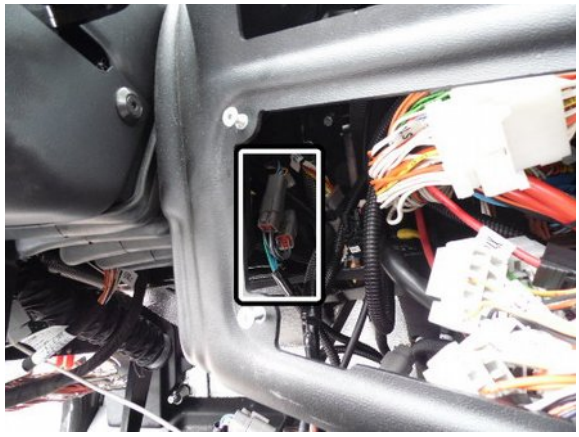

The cabin loom connects the CCIM to the machine connections and the other modules of the system.



Do not disconnect the camera power connection while the system is operating as this can damage the fuse.

<i>Step</i>	<i>Description</i>	<i>Diagram</i>
1.	<p>Run the CCIM and camera cables from under the dash to out over the top of the ECU mounting bracket.</p> <p>Connect the CCIM and signal light cables to the M12 connectors on the CCIM.</p> <p>Note: It doesn't which which of the M12 connectors the CCIM and signal light cables are plugged into.</p>	
2.	<p>Connect the power/camera and IO harnesses to the CCIM bulk head connectors</p>	
3.	<p>Connect the forward and reverse cables to the power/camera harness.</p> <p>Note; The white connector is not used.</p>	

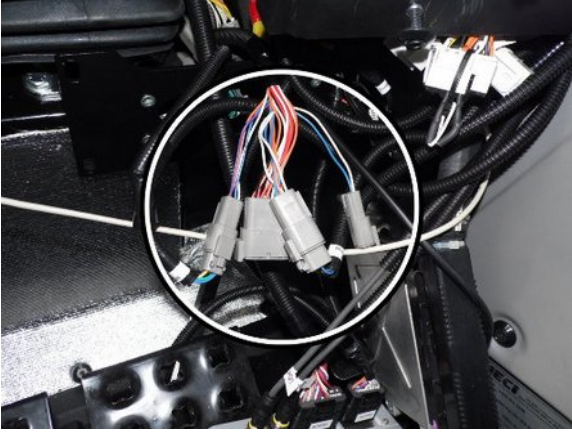

<i>Step</i>	<i>Description</i>	<i>Diagram</i>
4.	<p>Connect the 4 pin connector from the machine input harness into the IO harness.</p> <p>Connect the 6 pin connector from the machine cutout harness to the IO harness.</p> <p>Note: The 2 and 12 pin connections on the IO harness are not used.</p>	
5.	<p>Run the 8 pin cable from the CCIM over the top of the ECU mounting bracket.</p> <p>Then run the 8 pin and the 5 pin user control cable through the gap between the window and the dashboard.</p> <p>Note: The clip-on ferrites may need to be removed to run the cables through the gap between the window and the dashboard. Reattach the ferrites according to Appendix A: Attaching Display Connectors on page 48.</p>	
6.	<p>Run the cables through snake tube.</p> <p>Place cable tie points on the side of the window.</p> <p>Cable tie the snake tube to the cable tie points.</p> <p>Connect into the 8 pin and 5 pin connectors into the display</p>	

<i>Step</i>	<i>Description</i>	<i>Diagram</i>
7.	<p>Connect the spade lug on the black wire to the negative (black) battery terminal on the backup battery.</p> <p>Connect the spade lug on the blue wire to the positive (red) battery terminal on the backup battery.</p>	

Table 16: Cabin Loom Installation



If the M12 screw lock connectors on the display are over tightened it will twist the connector pins attaching the connector to the PCB. See Appendix A: Attaching Display Connectors on page 48 for the correct method of attaching to the display connectors.





If the clip-on ferrites were removed from the CCIM and user control cables. See Appendix B: Reattach Ferrites and page 52 for the correct reattachment position.

# Finalisation

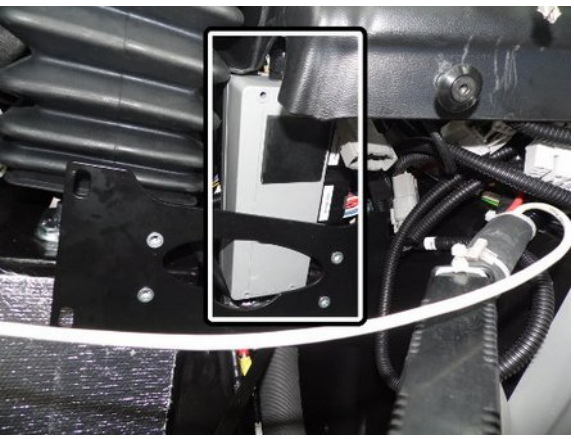
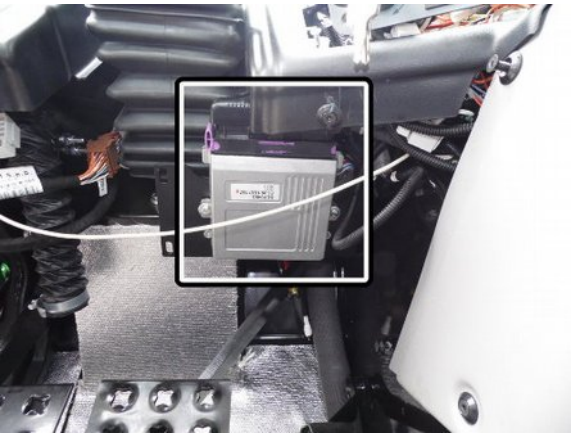
This section will complete the final power connections to power the system and finish any additional items.

<i>Step</i>	<i>Description</i>	<i>Diagram</i>
1.	<p>Connect the 3 pin connector from the radio power harness into the power/camera harness.</p> <p>Coil up and store the wire harnesses under the dashboard</p>	
2.	<p>Attach the backup battery to the velcro on the CCIM and attach the CCIM to the velcro installed earlier on the ECU mounting bracket</p>	
3.	<p>Reattach the ECU module to the ECU mounting bracket</p>	

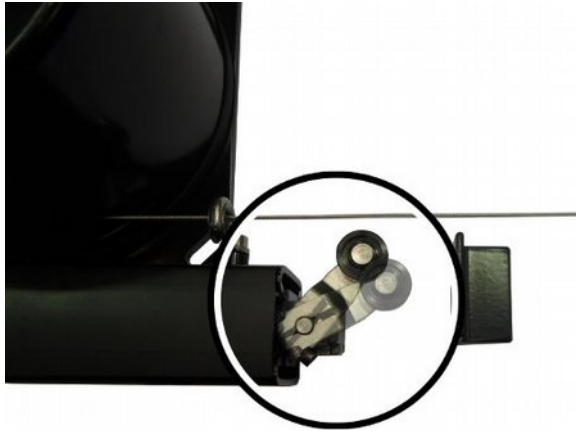
<i>Step</i>	<i>Description</i>	<i>Diagram</i>
4.	<p>Reconnect the main battery from the isolation switch.</p> <p>Turn the machine onto first stage /accessories and ensure the system is activated.</p>	
5.	<p>Adjust the display bracket for optimal viewing</p> <p>Set the machine into forward gear to active the forward camera. Adjust the forward camera so the front right wheel is visible.</p> <p>Set the machine into reverse gear to active the reverse camera. Adjust the reverse camera so the video is level.</p>	
6.	<p>Operate the boom movement controls to test if a false N07 fault occurs.</p> <p>If a N07 fault does occur, adjust the arm on the stow switch forwards towards the stow switch trigger.</p> <p>Note: The actual switch arm orientation may differ from the picture.</p>	



<i>Step</i>	<i>Description</i>	<i>Diagram</i>
7.	Perform a final check on all the cabling and sensors.  Replace all the covers	

Table 17: Finalisation

 Complete the system checklist once installation has been completed.

# Set Time & Sensor Calibration

Once the installation is complete, the time will need to be set and the sensors will require calibration.



A sensor calibration must be performed once the cable reeler and CPIM have been mounted. If the cable reeler or CPIM have been moved/repositioned a recalibration must be performed

<i>Step</i>	<i>Description</i>	<i>Diagram</i>
1.	<p>Press Enter on the user control dial to enter the menu system.</p> <p>Press the arrow buttons to select System Menu.</p> <p>Press Enter to select the menu.</p>	<hr/> <p style="font-size: small;">Main Menu</p> <hr/> <p>Attachment Selection Menu</p> <hr/> <div style="background-color: #4a7ebb; color: white; padding: 5px; text-align: center; font-weight: bold;">System Menu</div> <hr/> <p>Exit Menu</p> <hr/>
2.	<p>Select Advanced Menu</p>	<hr/> <p style="font-size: small;">System Menu</p> <hr/> <p>Volume / Brightness</p> <hr/> <p>Status Menu</p> <hr/> <p>Diagnostics Menu</p> <hr/> <p>System Tests</p> <hr/> <div style="background-color: #4a7ebb; color: white; padding: 5px; text-align: center; font-weight: bold;">Advanced Menu</div> <hr/> <p>Return to Main Menu</p> <hr/>

<i>Step</i>	<i>Description</i>	<i>Diagram</i>														
3.	Enter the password (Default Password: 2-8-4)	<table border="1"> <thead> <tr> <th colspan="2"><b>Enter Password</b></th> </tr> </thead> <tbody> <tr> <td>Number 1</td> <td>2</td> </tr> <tr> <td>Number 2</td> <td>8</td> </tr> <tr> <td>Number 3</td> <td>4</td> </tr> <tr> <td colspan="2"><b>Submit Password</b></td> </tr> <tr> <td colspan="2">Return to System Menu</td> </tr> </tbody> </table>	<b>Enter Password</b>		Number 1	2	Number 2	8	Number 3	4	<b>Submit Password</b>		Return to System Menu			
<b>Enter Password</b>																
Number 1	2															
Number 2	8															
Number 3	4															
<b>Submit Password</b>																
Return to System Menu																
4.	Select Set Time / Date	<table border="1"> <thead> <tr> <th colspan="2"><b>Advanced Settings</b></th> </tr> </thead> <tbody> <tr> <td colspan="2"><b>Set Time / Date</b></td> </tr> <tr> <td colspan="2">Sensor Calibrations</td> </tr> <tr> <td colspan="2">Change Language</td> </tr> <tr> <td colspan="2">Change Password</td> </tr> <tr> <td colspan="2">Return to System Menu</td> </tr> </tbody> </table>	<b>Advanced Settings</b>		<b>Set Time / Date</b>		Sensor Calibrations		Change Language		Change Password		Return to System Menu			
<b>Advanced Settings</b>																
<b>Set Time / Date</b>																
Sensor Calibrations																
Change Language																
Change Password																
Return to System Menu																
5.	<p>Enter the correct time and date for your area.</p> <p>Press the arrow keys to select a time/date parameter</p> <p>Press Enter and the parameter will change to red, press the arrow keys to change the value and then press the Enter key to store the value.</p> <p>Note: The hour parameter is in 24 hour clock</p> <p>Repeat for the rest of the time values</p>	<table border="1"> <thead> <tr> <th colspan="2"><b>Set Time / Date</b></th> </tr> </thead> <tbody> <tr> <td><b>Hour</b></td> <td><b>15</b></td> </tr> <tr> <td>Minute</td> <td>54</td> </tr> <tr> <td>Day</td> <td>10</td> </tr> <tr> <td>Month</td> <td>2</td> </tr> <tr> <td>Year</td> <td>2016</td> </tr> <tr> <td>Region</td> <td>Melbourne</td> </tr> </tbody> </table>	<b>Set Time / Date</b>		<b>Hour</b>	<b>15</b>	Minute	54	Day	10	Month	2	Year	2016	Region	Melbourne
<b>Set Time / Date</b>																
<b>Hour</b>	<b>15</b>															
Minute	54															
Day	10															
Month	2															
Year	2016															
Region	Melbourne															

<i>Step</i>	<i>Description</i>	<i>Diagram</i>
6.	Scroll to the next page and select Save to store the new time/date and return to the Advanced Menu.	<p>The diagram shows a menu with a blue header bar containing the text "Save". Below the header bar is a white bar containing the text "Return to Advanced Menu".</p>
7.	Select Sensor Calibrations	<p>The diagram shows a menu with a blue header bar containing the text "Advanced Settings". Below the header bar are four white bars containing the text "Set Time / Date", "Sensor Calibrations", "Change Language", and "Change Password". Below these bars is a white bar containing the text "Return to System Menu".</p>
8.	Select Calibrate Carrier Angle and then follow the instructions on the screen to complete the calibration.  Repeat for Calibrate Boom Angle and Calibrate Boom Length.	<p>The diagram shows a menu with a blue header bar containing the text "Sensor Calibration Menu". Below the header bar are four white bars containing the text "Calibrate Carrier Angle", "Calibrate Boom Angle", "Calibrate Boom Length", and "Return to Advanced Menu".</p>

Table 18: Sensor Calibration

# Schematics

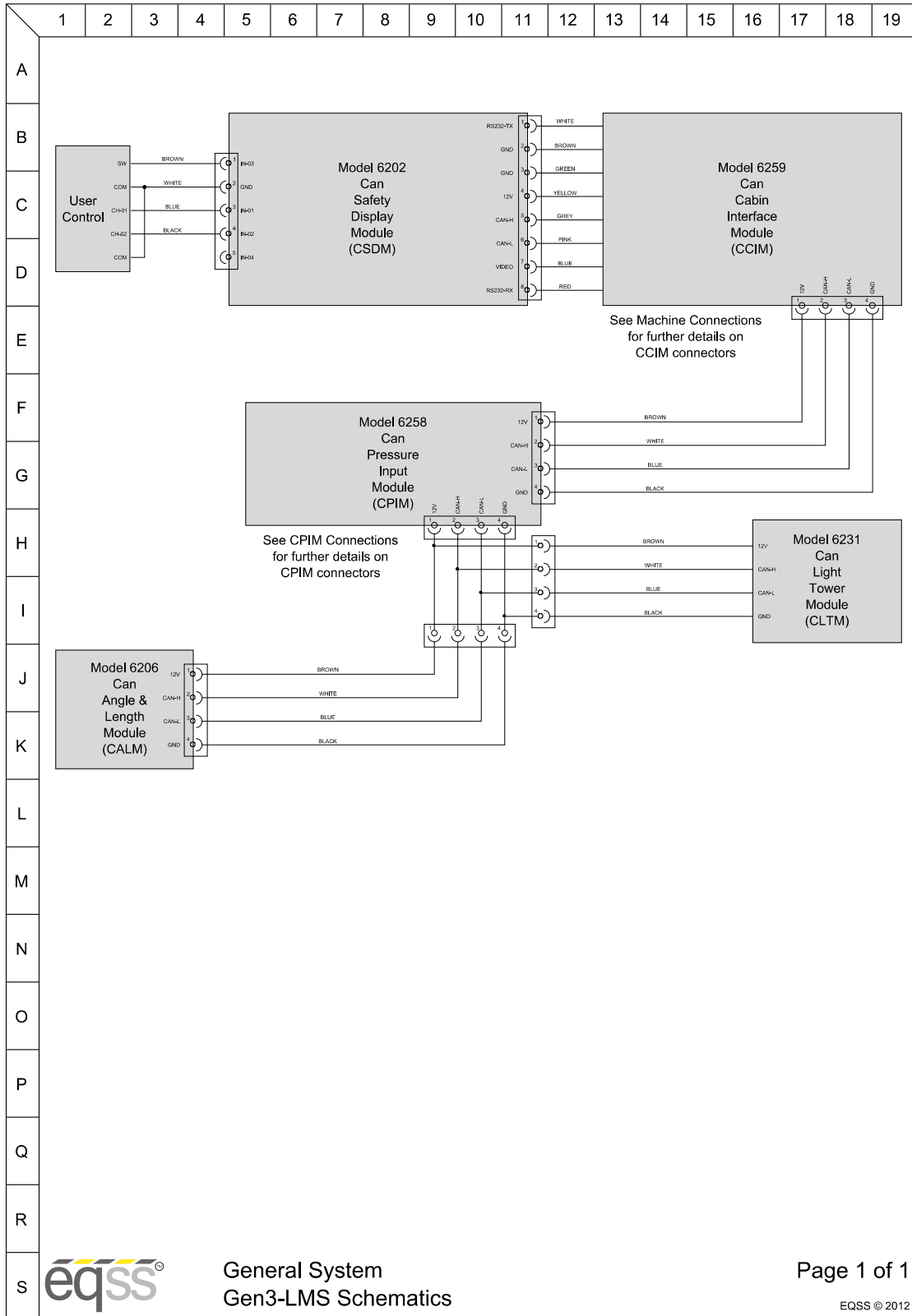

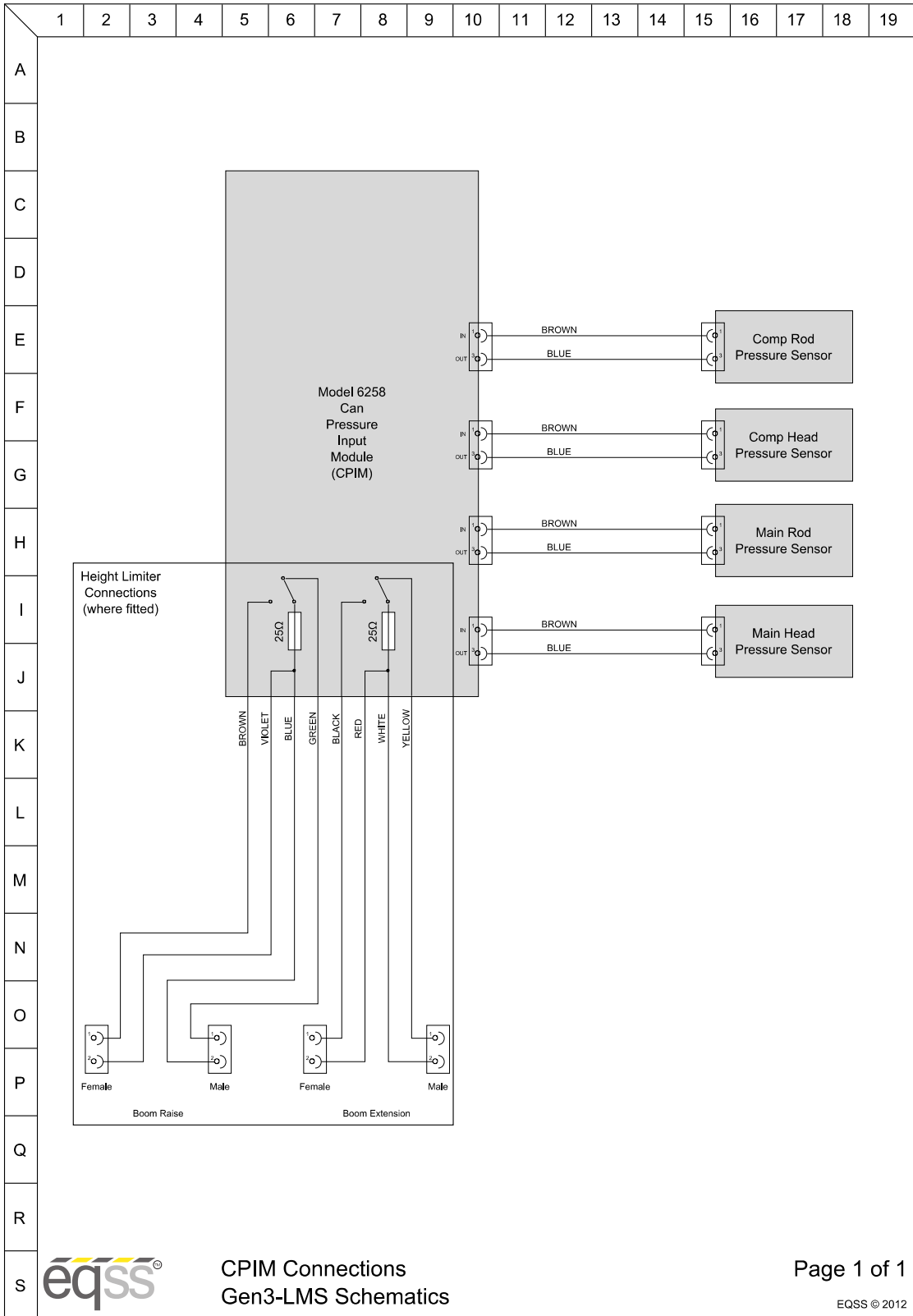

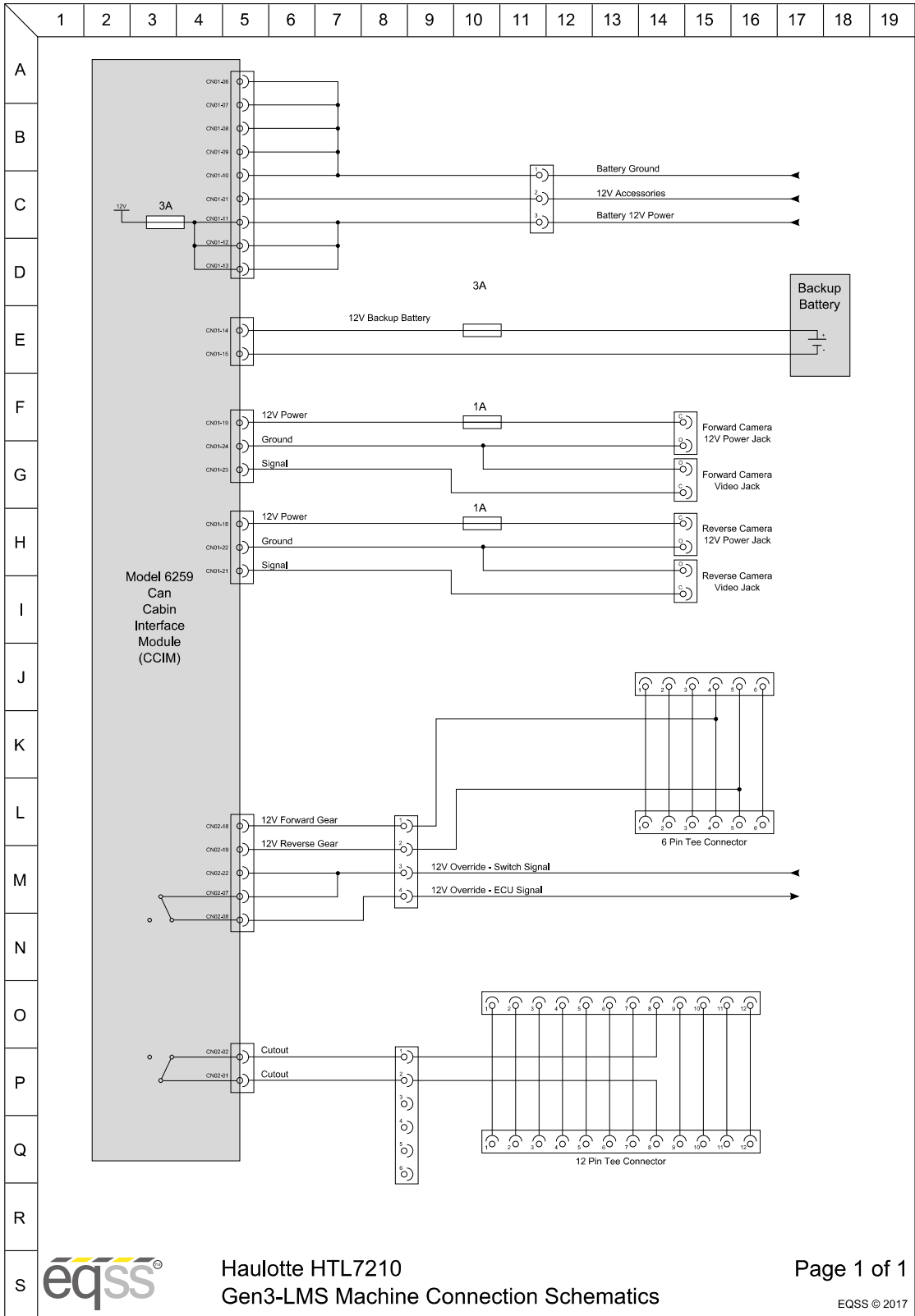

# Appendix A: Attaching Display Connectors

The procedure below describes the correct method of attaching the cables to the screw lock connectors on the display.



If the M12 screw lock connectors on the display are over tightened, it will twist the connector pins attaching the connector to the PCB.

<i>Step</i>	<i>Description</i>	<i>Diagram</i>
1.	<p>Connect the cable from the user control to the top 5 pin connector on the display.</p> <p>Connect the cable from the CCIM to the bottom 8 pin connector on the display.</p>	
2.	<p>Line up the alignment hole on the cable connector with the alignment notch on the display connector.</p>	





<i>Step</i>	<i>Description</i>	<i>Diagram</i>
3.	Push the female connector from the cable into the male connector on the display.	
4.	Rotate the nut on the female connector by hand in a clockwise direction, until the tension on the nut starts to increase.	
5.	Push the cable in again and repeat steps 3 and 4 until the connector is secure.	

Table 19: Install Display Connector Procedure



The method to correctly secure the cable is to push-twist-push-twist until the connector is fully inserted and secure. This will minimise the twisting force applied to the connector.

Below is a picture of a damaged connector on the PCB inside the display. This damaged occurred because the connector was over tightened.

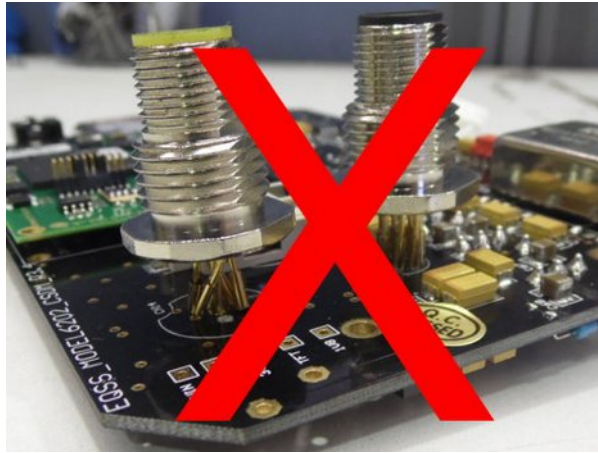

*Illustration 4: Damaged Display Connector*



Do not use any tools to tighten the connector.



*Illustration 5: Do Not Use Tools To Tighten Connector*



Do not over-tighten the nuts on the back of the display connectors. These nuts should only be hand tightened. If the nuts are overtightened it will damage the PCB inside the display.



*Illustration 6: Do Not Over Tighten Nuts*



Damage to the display connectors is not covered under warranty.

# Appendix B: Reattach Ferrites

If the clip-on ferrites on the displays are removed during installation, they will need to be reattached as shown in the procedure below.

 If the ferrites are not reinstalled or attached in the specified location the Gen3-LMS kit will not meet the AS/NZS CISPR 22:2006 certification.

<i>Step</i>	<i>Description</i>	<i>Diagram</i>
1.	Attach the two clip-on ferrites at a location of 60 mm and 260 mm from the start of the connector to the start of the ferrite.  Do this for both the CCIM and user control cables that plug into the display.	

Table 20: Reattach Ferrites Procedure

# Indexes and Tables

## Illustration Index

Illustration 1: Machine Boom.....	8
Illustration 2: Machine Chassis.....	9
Illustration 3: Cable Reeler Mounting Position.....	15
Illustration 4: Damaged Display Connector.....	50
Illustration 5: Do Not Use Tools To Tighten Connector.....	50
Illustration 6: Do Not Over Tighten Nuts.....	51

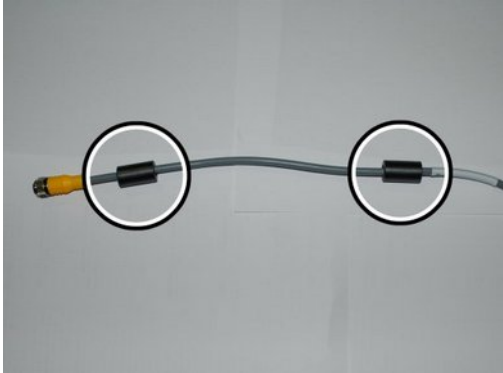
## Index of Tables

Table 1: Component Installation Index.....	7
Table 2: Cable Installation Index.....	7
Table 3: Cover removal.....	12
Table 4: Cable Reeler Installation.....	14
Table 5: Pressure Manifold Installation.....	18
Table 6: Compensation Pressure Sensor Installation.....	19
Table 7: Reverse Camera Installation.....	21
Table 8: Forward Camera Installation.....	23
Table 9: Signal Light Installation.....	26
Table 10: Can Pressure Input Module (CPIM) Installation.....	27
Table 11: External Cable Completion.....	29
Table 12: Display Installation.....	30
Table 13: User Input Control Installation.....	31
Table 14: CCIM Installation.....	33
Table 15: Machine Connections.....	35
Table 16: Cabin Loom Installation.....	38
Table 17: Finalisation.....	41
Table 18: Sensor Calibration.....	44
Table 19: Install Display Connector Procedure.....	49
Table 20: Reattach Ferrites Procedure.....	52



---

**Equipment Safety Systems Pty. Ltd.** ABN: 31 061 789 151  
27 Cumberland Drive, Seaford 3198, Victoria, Australia

Tel: +61 3 8770 6555  
Fax: +61 3 8770 6590  
Web: [www.eqss.com.au](http://www.eqss.com.au)