



# eqss<sup>TM</sup> Gen-3 LMS Telehandler Load Management System

## Installation Manual for HTL5210



### **PLEASE NOTE:**

**\*\*\*Do Not Swap Components between Gen3-LMS kits\*\*\*  
When installing multiple Gen3-LMS kits, make sure the serial  
number on the sticker matches the serial number on the  
machine.**

**\*\*\*Failure To Follow Installation Manual Will Void Warranty\*\*\***

## Documentation Conventions

The list below highlights important documentation conventions.



Text presented in this manner is intended to provide the user with some general information. The user should ensure information presented in this manner is clearly understood.



Text presented in this manner provides the user with information to assist in completion of the current procedure being explained.



Text presented in this manner indicates that a failure to follow directions could result in damage to equipment, loss of information, bodily harm, or loss of life.

## **Important Information**

Information contained in this publication regarding this device's applications and the like is provided only for your convenience and may be superseded by updates. It is your responsibility to ensure that the application or our equipment meets with your specifications.

EQUIPMENT SAFETY SYSTEMS MAKE NO REPRESENTATIONS OR WARRANTIES OF ANY KIND WHETHER EXPRESS OR IMPLIED, WRITTEN OR ORAL, STATUTORY OR OTHERWISE, RELATED TO THE INFORMATION, INCLUDING BUT NOT LIMITED TO, IT'S CONDITION, QUALITY, PERFORMANCE, MERCHANTABILITY OR FITNESS FOR PURPOSE.

Equipment Safety Systems disclaims all liability arising from this information and its use. Use of Equipment Safety Systems' products as critical components in life support systems is not authorised except with express written approval by Equipment Safety Systems. No licenses are conveyed, implicitly or otherwise, under any Equipment Safety Systems intellectual property rights.

# Table of Contents

Tools Required for Installation.....	6
Installation Index.....	7
Covers.....	12
Cable Reeler Installation.....	13
Cable Reeler Mounting Position.....	15
Pressure Sensor Installation.....	16
Pressure Manifold.....	16
Pressure Manifold Components.....	18
Compensation Pressure Sensors.....	19
Reverse Camera.....	21
Forward Camera.....	23
Signal Light Installation.....	25
Can Pressure Input Module (CPIM).....	27
Cutout Harness.....	29
External Cable Completion.....	30
Display Installation.....	32
User Input Control.....	33
Can Cabin Interface Module (CCIM).....	34
Cabin Loom.....	35
Machine Connections.....	38
4 Pin Machine Input Harness Connections.....	39
2 Pin Stabiliser Harness Connections.....	40
PF Connector.....	40
Finalisation.....	41
Set Time & Sensor Calibration.....	44

Schematics..... 47

Appendix A: Attaching Display Connectors..... 50

Appendix B: Reattach Ferrites..... 54

Indexes and Tables..... 55

# Tools Required for Installation


The tools required to perform the installation of the TSS are listed below

- Pencil or Texta
- Drill
- Drill bits
  - 3.3 mm
  - 4.5 mm
  - 5 mm
  - 6.8 mm
  - 8.5 mm
- Centre punch
- Tap T-Handle
- Taps
  - M6
  - M8
- Drill and tap oil
- Metric Allen keys
- Phillips Head screw driver
- Spanners and sockets
  - 7 mm
  - 10 mm
  - 13 mm
- Loctite thread locker
- Side cutters
- Stanley knife
- Crimpers
- Wire strippers
- Torque Wrench

# Installation Index

The components and cables of the Gen-3 Telehandler Load Management System are outline in the tables below. The following pages show where the components are installed and the cable routing.

See the appropriate manual section for a detailed installation description for each component.



Refer to this section for any component placement or cable routing issues

<i>Item</i>	<i>Component Description</i>
1	Cable Reeler
2	Main Lift Cylinder Pressure Sensors
3	Compensation Cylinder Pressure Sensors
4	Can Pressure Input Module (CPIM)
5	Height Limiter Connection
6	Forward Camera
7	Signal Light
8	Rear Camera
9	Can Cabin Interface Module (CCIM)

Table 1: Component Installation Index

<i>Colour</i>	<i>Cable Description</i>
Light Purple	Boom Cable
Dark Green	Main Cylinder Pressure Sensor Cables
Dark Blue	Compensation Cylinder Pressure Sensors Cables
Red	Height Limiter Cable
Light Green	Forward Camera Cable
Brown	Signal Light Cable
Light Blue	Rear Camera Cable
Dark Purple	CCIM Cable

Table 2: Cable Installation Index



Illustration 1: Machine Boom



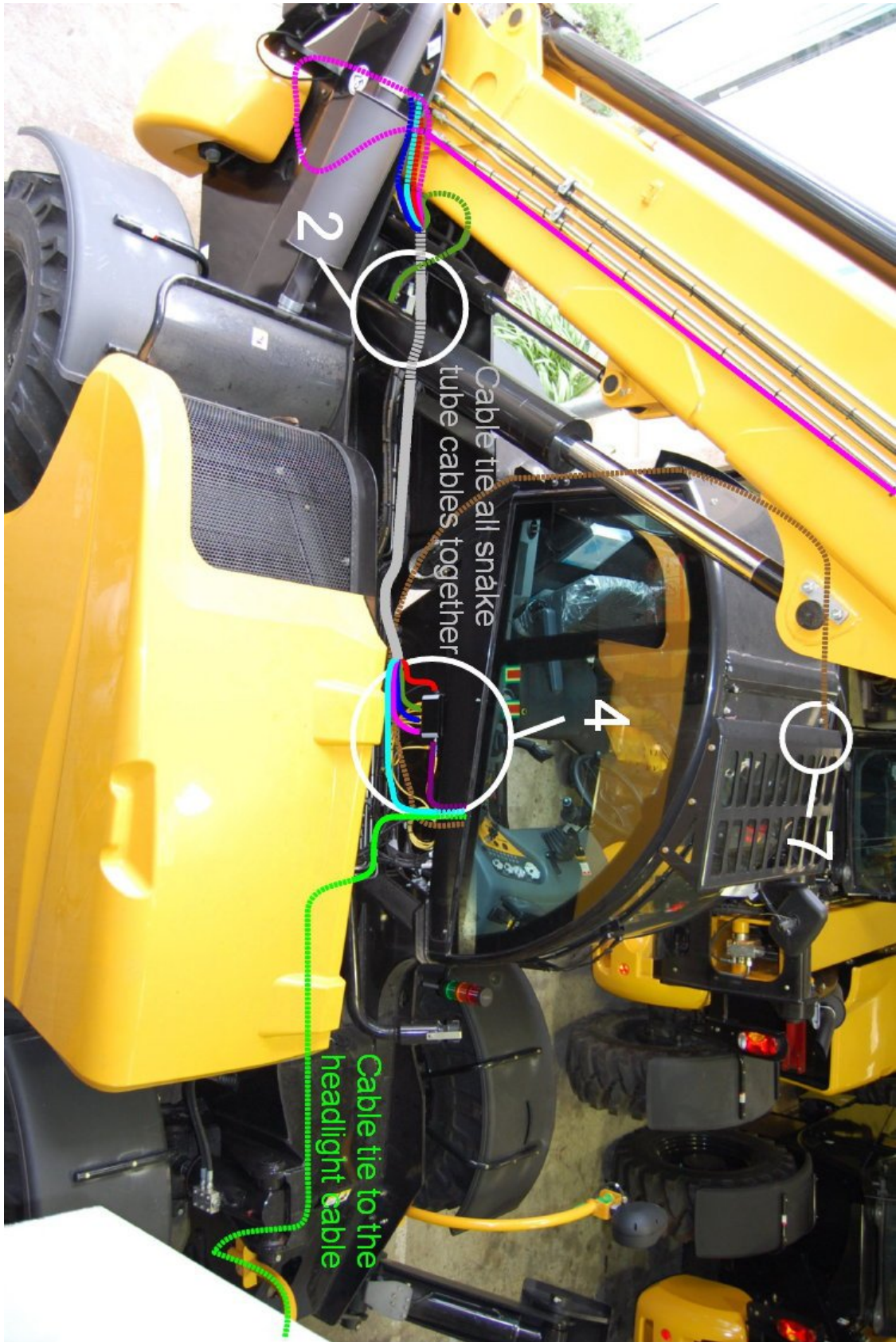
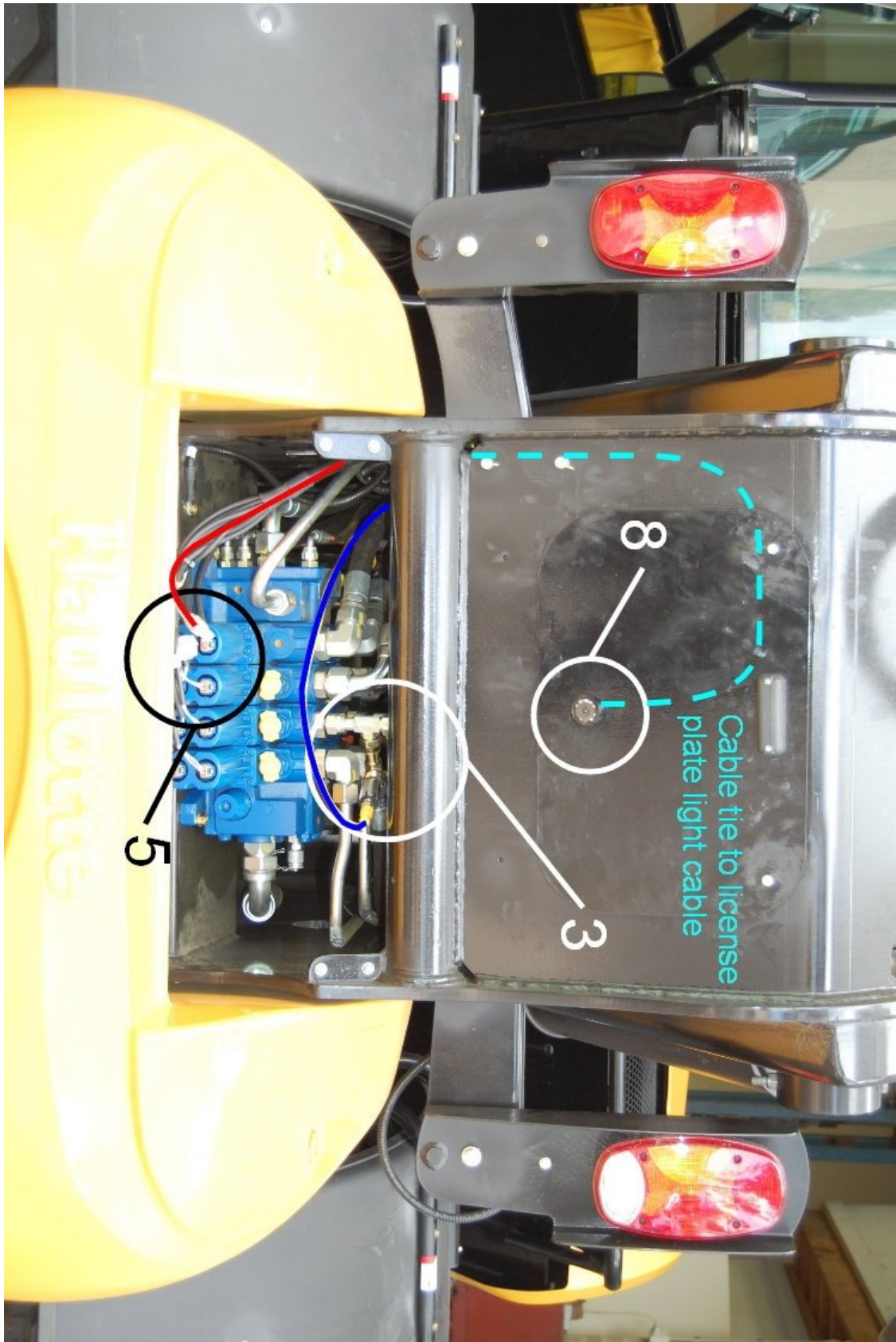


Illustration 2: Machine Chassis

Note: The signal light is not shown



*Illustration 3: Rear of Machine*



Illustration 4: Cabin

# Covers

Remove the following covers before starting the installation

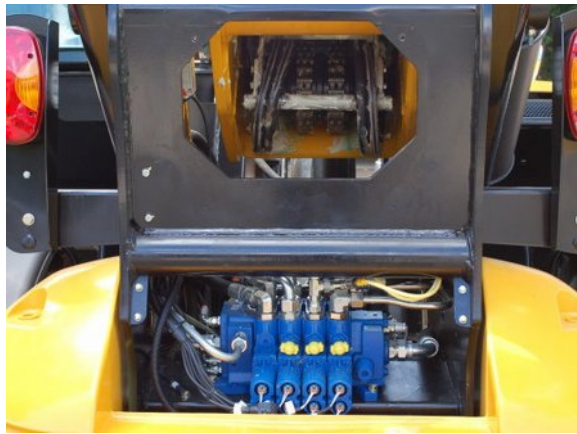


<i>Step</i>	<i>Description</i>	<i>Diagram</i>
1.	<p>Remove the top rear cover and disconnect the license plate light.</p> <p>Remove the lower rear cover to access the hydraulic block</p>	
2.	<p>Remove the side panel next to the cabin under the boom.</p>	
3.	<p>Inside the cabin remove the plastic cover under the joystick.</p> <p>Undo the bolts attaching the dashboard.</p> <p>Remove the fuse panel cover below the steering wheel.</p>	

Table 3: Cover removal


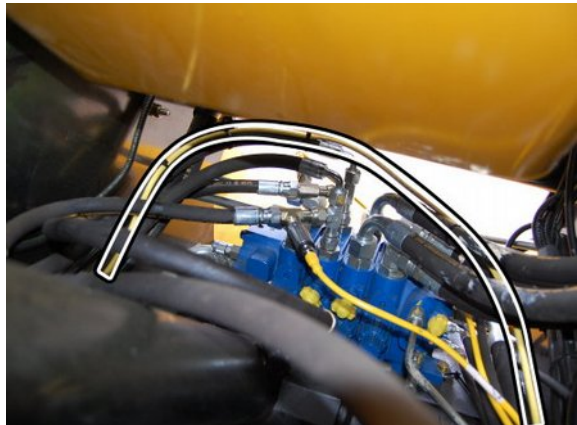
# Cable Reeler Installation

The cable reeler is used to measure the boom extension to determine the maximum lifting capacity.



A false N07 fault can occur if the boom jumps off the stow switch due to pressurising the hydraulic system and without operating the boom extension control. Ensure the stow switch arm is correctly adjusted to prevent this error.

<i>Step</i>	<i>Description</i>	<i>Diagram</i>
1.	<p>Drill and tap the holes for the cable reeler according to the mounting diagram on page 15.</p> <p>Mount using the supplied M6 x 12 mm bolts and washers.</p>	
2.	<p>Drill and tap an M8 hole for the cable anchor. Ensure the cable anchor is positioned so the cable runs in line with the boom.</p> <p>Mount the cable anchor and attach the cable.</p>	
3.	<p>Drill and tap the M6 holes for the stow switch trigger bracket.</p> <p>Mount the stow switch trigger bracket using the supplied M6 x 12 mm bolts and washers.</p> <p>Adjust the length of the trigger plate to ensure the stow switch is pressed when the boom is retracted.</p>	

<i>Step</i>	<i>Description</i>	<i>Diagram</i>
4.	Connect the supplied M12 10 metre cable (CB001027) into the cable reeler connection.	
5.	<p>Run the cable along the hydraulic pipes running down the boom, secure using cable ties every 150 mm to 200 mm.</p> <p>Cable tie to the flexible hydraulic hoses down to the chassis. Make sure the cable isn't pinched or stretched when the boom is raised or lowered.</p> <p>Run the remainder of the cable towards the cabin and insert into snake tube with the reverse camera cable during External Cable Completion on page 30.</p>	 <p>Picture taken from under boom towards back of machine, showing the boom cable path along the flexible hydraulic lines leading up the boom</p>

*Table 4: Cable Reeler Installation*


 For further details on running the boom cable refer to the Installation Index on page 7

# Cable Reeler Mounting Position



Illustration 5: Cable Reeler Mounting Position

# Pressure Sensor Installation

The hydraulic pressure sensors are used to measure the lifting load of the telehandler.

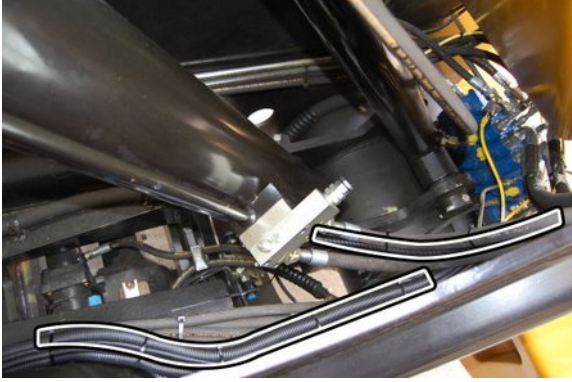
## Pressure Manifold



Failure to tighten the bolts to the correct torque on the pressure manifold may result in a pressure failure on the counterbalance valve causing an uncontrolled fall of the boom.

<i>Step</i>	<i>Description</i>	<i>Diagram</i>
1.	<p>Raise the boom to approximately 40 degrees.</p> <p>Support and secure the boom using an A Frame or similar apparatus. <b>It must support at least 2 tons.</b></p> <p>Apply the handbrake and insert chock under wheels.</p> <p>Remove the counterbalance valve on the side of the hydraulic lifting ram.</p> <p><b>Removing the counterbalance valve will release the hydraulic pressure which may result in a spray of oil.</b></p> <p>Secure the pressure manifold using the bolts and seals described on page 18. Tighten the <b>12.9 grade</b> bolts for the manifold to <b>41 NM</b> using a torque wrench.</p> <p><b>Start the machine, pressurise the boom and check for leaks.</b></p>	



<i>Step</i>	<i>Description</i>	<i>Diagram</i>
2.	<p>Connect the supplied M12 4 metre cables (CB001026) into each of the pressure sensors.</p> <p>Add both cables to 3 m of snake tube. Cable tie to the flexible hydraulic hoses connected to the main lift cylinder. Make sure the cable isn't pinched or stretched when the boom is raised or lowered.</p> <p>Run the snake tube and cables towards the cabin and cable tie with the other cables during External Cable Completion on page 30.</p>	

*Table 5: Pressure Manifold Installation*



For further details on running the pressure sensor cables refer to the Installation Index on page 7

# Pressure Manifold Components

Parts List					
ITEM	QTY	PART NUMBER	DESCRIPTION	MATERIAL	STOCK NUMBER
1	1	MT1440SLT-TTCCV1-100	Tool Tilt Cylinder Control Valve Manifold	MA001072 (Bar, Steel 1020, 100mm x 40mm)	ME001053
2	4	SE001006	O-Ring, OR 15mm x 2.5mm, N70	Nitrile (N70)	SE001006
3	4		Socket Head Bolt M8 x 1.25 x 70mm, Grade 12.9 High Tensile	Steel, High Strength Low Alloy	FA001266

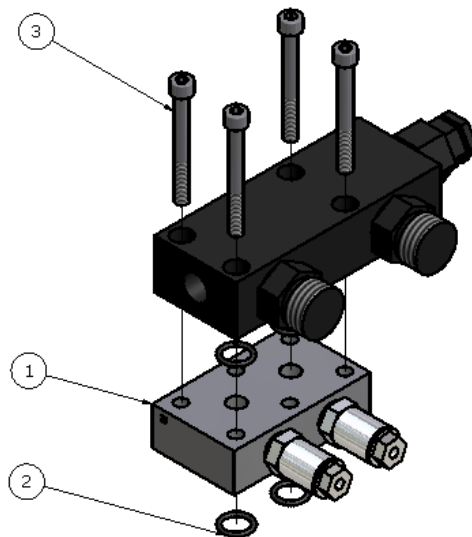


Illustration 6: Pressure Manifold Components

# Compensation Pressure Sensors

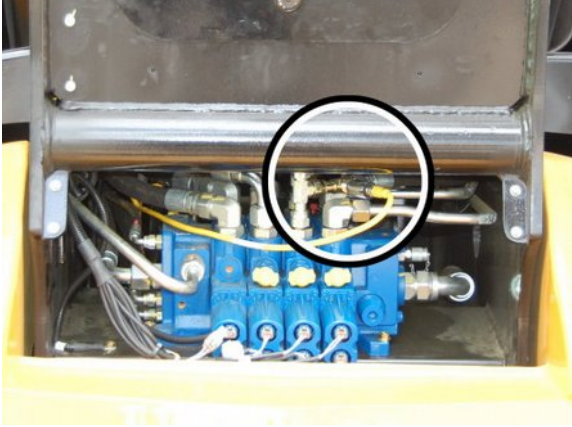
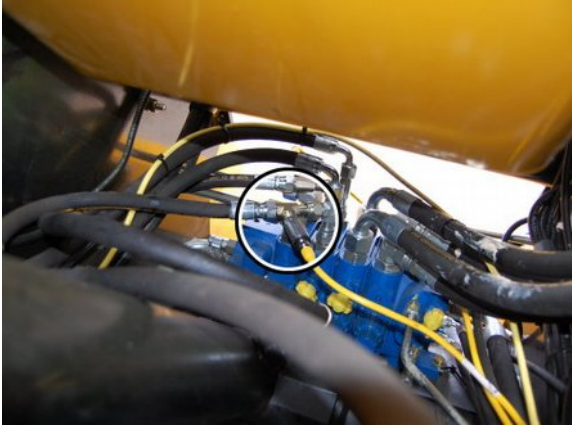
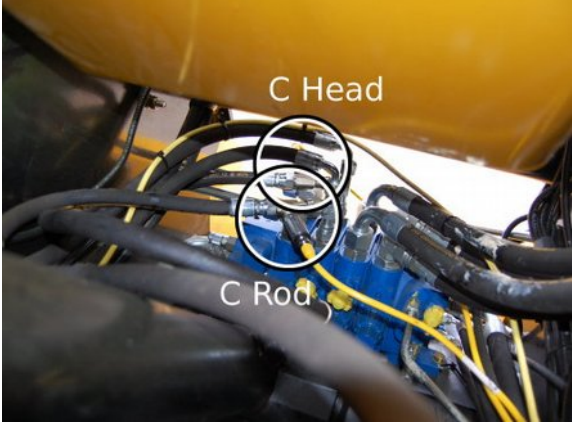
Step	Description	Diagram
1.	<p>Undo the hydraulic connection for the head compensation into the manifold block at the rear of the machine.</p> <p>Install the supplied tee piece and pressure sensor in line with the hydraulic connection.</p>	 <p>View from the rear of the machine</p>
2.	<p>Undo the hydraulic connection for the rod compensation into the manifold block at the rear of the machine.</p> <p>Install the supplied tee piece and pressure sensor in line with the hydraulic connection</p> <p><b>Start the machine, pressurise the boom and check for leaks.</b></p>	 <p>View from under the boom towards the rear of the machine</p>
3.	<p>Connect the supplied M12 4 metre cables (CB001026) into each of the pressure sensors.</p> <p>Add both cables to 3 m of snake tube.</p> <p>Run the snake tube and cables towards the cabin and cable tie with the other cables during External Cable Completion on page 30.</p>	 <p>C Head</p> <p>C Rod</p>

Table 6: Compensation Pressure Sensor Installation




Angle the tee connections to ensure the hydraulic connections and pressure sensor do not hit the boom when the boom is lowered



For further details on running the pressure sensor cables refer to the Installation Index on page 7

# Reverse Camera

The rear camera video is displayed on the screen when the machine is in reverse gear to allow the operator to see behind the telehandler while reversing.



Do not disconnect the camera power connection while the system is operating as this can damage the fuse.

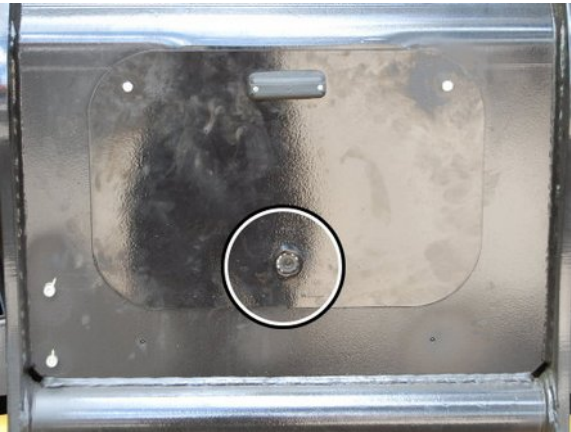

<i>Step</i>	<i>Description</i>	<i>Diagram</i>
1.	<p>Remove the cover at the rear of the machine.</p> <p>Drill a 31mm hole in the location shown. Making sure to leave enough room for a license plate</p> <p>Insert the camera through the hole and adjust the angle using the alignment washers.</p>	
2.	<p>Connect the camera power and signal connectors to the supplied 5m camera cable (CB001032).</p> <p>Note; The white connector is not used.</p> <p>Cable tie the camera cable to the license plate light cable.</p> <p>Run the remainder of the cable towards the cabin and insert into snake tube with the boom cable during External Cable Completion on page 30.</p>	

Table 7: Reverse Camera Installation



The camera's viewing angle may need to be adjusted once the system is installed and the display is operational.



Once the cable has been tied to the license plate light cable disconnect the cable cable to remove the rear cover until the installation is finalised



For further details on running the camera cable refer to the Installation Index on page 7

# Forward Camera

The forward camera video is displayed on the screen when the machine is in forward gear to allow the operator to see past the boom to obstructions that would damage the right front tyre.



Do not disconnect the camera power connection while the system is operating as this can damage the fuse.

<i>Step</i>	<i>Description</i>	<i>Diagram</i>
1.	<p>Mount the camera to the side mirror using the p-clips as shown.</p> <p>Secure using two M6 nuts.</p>	
2.	<p>Connect the camera power and signal connectors to the supplied 5m camera cable (CB001032).</p> <p>Note; The white connector is not used.</p> <p>Run the cable along the same path as the headlight cable, run it through the headlight post, then under the chassis to the side of the cabin. Cable tie to the headlight cable every 150 mm to 200 mm.</p> <p>Complete the cable installation during External Cable Completion on page 30.</p>	

Table 8: Forward Camera Installation



The camera's viewing angle may need to be adjusted once the system is installed and the display is operational.



For further details on running the camera cable refer to the Installation Index on page 7






# Signal Light Installation

The signal light warns other workers when the telehandler is lifting loads close to its maximum capacity.



Ensure the power supply voltage is greater than 13.5V otherwise the signal light may not illuminate correctly.

<i>Step</i>	<i>Description</i>	<i>Diagram</i>
1.	<p>Remove the magnet from the bottom of the signal light mounting bracket and flip the signal light mounting bracket so the mounting holes are on the bottom.</p> <p>Drill and tap two M4 holes to mount the signal light bracket to the top of the windshield guard bar on the roof.</p> <p>Mount using the supplied M4 bolts and washers.</p>	
2.	<p>Run the cable along the roof towards the rear of the cabin.</p> <p>Cable tie to the air conditioning connections towards the boom side of the roof.</p>	

<i>Step</i>	<i>Description</i>	<i>Diagram</i>
3.	<p>Run the cable underneath the hose cover running down to the chassis.</p> <p>Note: It might be necessary to remove the hose cover to run the cable.</p> <p>Cable tie with the other cables during External Cable Completion on page 30.</p>	

*Table 9: Signal Light Installation*

# Can Pressure Input Module (CPIM)

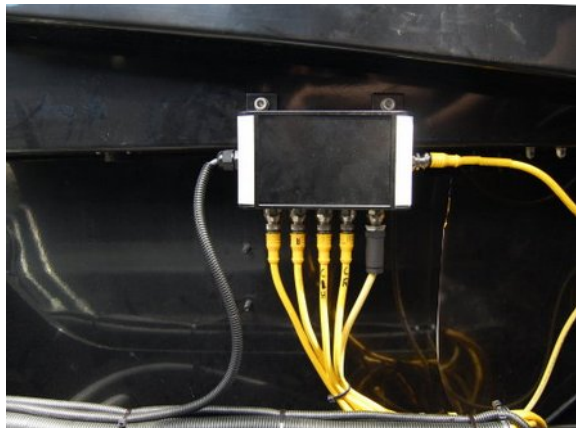
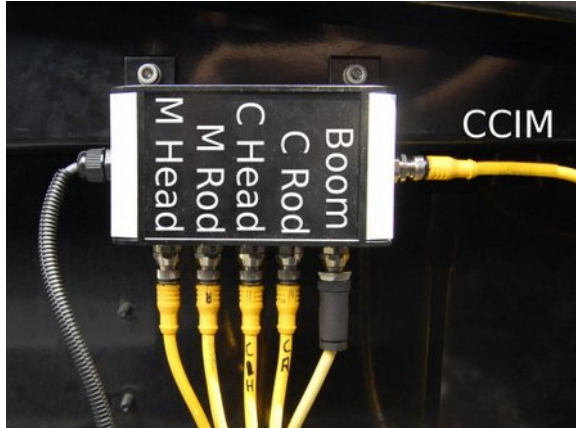
The CPIM is responsible for processing the information send from the pressure sensors.



Accidentally swapping the pressure sensor connections will not damage system and can be determined if the display is showing a negative load.



Do not plug the pressure sensor cable into the far right side boom cable. This will damage the system.

<i>Step</i>	<i>Description</i>	<i>Diagram</i>
1.	<p>Drill and tap two M8 holes for the CPIM bracket in the cab side panel.</p> <p>Mount using the supplied M8 x 12mm bolts and washers.</p>	
2.	<p>Connect the cables for the pressure sensors, boom cable and signal light to CPIM according to the picture shown.</p> <p>Note: The CCIM cable will be installed during External Cable Completion on page 30.</p>	



<i>Step</i>	<i>Description</i>	<i>Diagram</i>
3.	<p>Run the height limiter cable from out the left side of the CPIM to the rear of the machine to the hydraulic block.</p> <p>Connect the tee connector labelled YV300 from the height limiter cable to YV300 on the hydraulic block and the tee connector labelled YV340 from the height limiter cable to YV340 on the hydraulic block.</p> <p>Place a single cable tie to hold the cable's position then disconnect the tee's from YV300 and YV340, otherwise the boom will not move.</p> <p>Complete the cable installation during External Cable Completion on page 30.</p>	

Table 10: Can Pressure Input Module (CPIM) Installation



For further details on running the height limiter cable refer to the Installation Index on page 7

# Cutout Harness


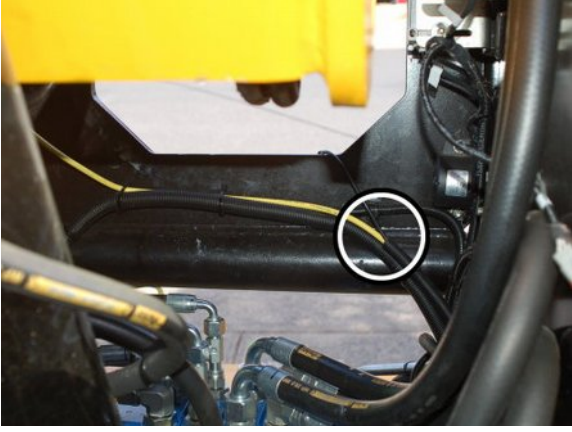

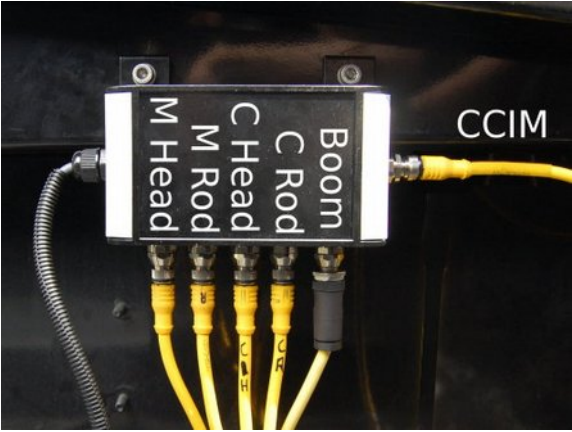

<i>Step</i>	<i>Description</i>	<i>Diagram</i>
1.	<p>Connect the tee connector labelled Lower from the cutout harness to the lower pilot connector (YV320) on the spool control block.</p> <p>Place a single cable tie to hold the cable's position then disconnect the tee's from lower pilot connector, otherwise the boom will not move.</p> <p>Run the other side of the harness with the 6 pin connector towards the cabin and cable tie with the other cables during External Cable Completion on page 30.</p>	

Table 11: Cutout Harness Installation

# External Cable Completion

All external cabling is completed in this step.

<i>Step</i>	<i>Description</i>	<i>Diagram</i>
1.	Locate the reverse camera cable and the boom cable at the rear of the machine and run both cables through the supplied 2.5 m section of snake tube up to the CPIM.	
2.	<p>Cable tie the pressure sensor, boom, height limiter, cutout and reverse camera cables together up to the CPIM (4 sets of snake tube, see the grey cable highlight on 9).</p> <p>Coil up the additional cabling for the pressure sensor, boom, signal light and height limiter cables and store underneath the CPIM.</p>	
3.	Connect the supplied M12 4 metre cable (CB001026) into the right side of the CPIM for the CCIM cable.	

<i>Step</i>	<i>Description</i>	<i>Diagram</i>
4.	<p>Run the CCIM, cutout, signal light and camera cables up through the hole into the cabin under the dashboard.</p> <p>Note: Pull the entire length of cable through into the cabin, excess cable will be stored under the covers in the cabin.</p>	

*Table 12: External Cable Completion*

# Display Installation

The display shows the current safety status of the telehandler.


<i>Step</i>	<i>Description</i>	<i>Diagram</i>
1.	<p>Position the display bracket in the top right of the dashboard in the approximate location shown.</p> <p>Drill two 7 mm holes to attach the bracket to the dashboard.</p> <p>Secure the bracket to the dashboard using the supplied large washers and nuts</p> <p>Attach the display to the bracket and tighten the grub screw</p>	

Table 13: Display Installation



Adjust the display bracket for optimal viewing angle once the display is powered



If the M12 screw lock connectors on the display are over tightened it will twist the connector pins attaching the connector to the PCB. See Appendix A: Attaching Display Connectors on page 50 for the correct method of attaching to the display connectors.



# User Input Control

The user input control consists of a single dial switch mounted in the dashboard.



Step	Description	Diagram
1.	<p>Drill a 34 mm hole into the dashboard.</p> <p>Install the user input control dial in the dashboard, aligned so the Enter cap is facing up.</p>	
2.	<p>If the above location is used for the emergency stop button. Install the user control next to the steering wheel as shown.</p>	

Table 14: User Input Control Installation



If the M12 screw lock connectors on the display are over tightened it will twist the connector pins attaching the connector to the PCB. See Appendix A: Attaching Display Connectors on page 50 for the correct method of attaching to the display connectors.

# Can Cabin Interface Module (CCIM)

The CCIM connects the system into the machine electronics.



<i>Step</i>	<i>Description</i>	<i>Diagram</i>
1.	<p>Position the backup battery (shown behind the CCIM) to the side panel beside the joystick using double sided velcro tape.</p> <p>Position the CCIM in front of the backup battery using double sided velcro tape.</p> <p>Remove the battery and CCIM from the velcro to allow the connections to be completed. Reattach to the velcro in the section Finalisation on page 41.</p>	

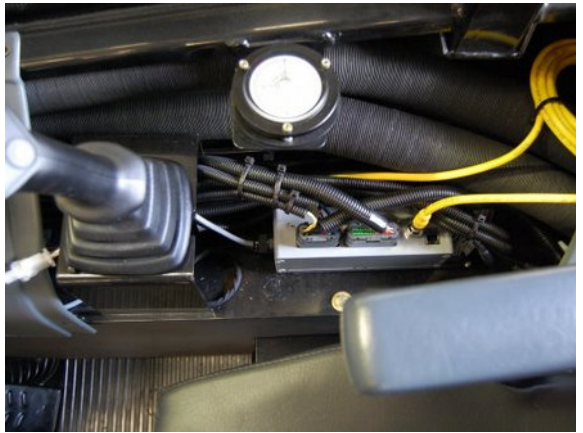


Table 15: CCIM Installation

# Cabin Loom

The cabin loom connects the CCIM to the machine connections and the other modules of the system.



Do not disconnect the camera power connection while the system is operating as this can damage the fuse.

<i>Step</i>	<i>Description</i>	<i>Diagram</i>
1.	Run the CCIM and camera cables under the joystick to the CCIM position	
2.	Connect the CCIM and signal light cables to the M12 connectors on the CCIM.  Note: It doesn't matter which of the M12 connectors the CCIM and signal light cables are plugged into.	
3.	Connect the cabin loom to the CCIM bulk head connectors	





Step	Description	Diagram
4.	<p>Connect the camera power and signal cables to the cabin loom.</p> <p>Note; The white connector is not used.</p>	
5.	<p>Run the harness connectors under the joystick to the dashboard opening</p>	
6.	<p>Run the 5 pin user control cable and the 8 pin cable from the CCIM through the gap between the window and the dashboard.</p> <p>Connect into the 5 and 8 pin connectors into the display</p>	

Table 16: Cabin Loom Installation




If the M12 screw lock connectors on the display are over tightened it will twist the connector pins attaching the connector to the PCB. See Appendix A: Attaching Display Connectors on page 50 for the correct method of attaching to the display connectors.




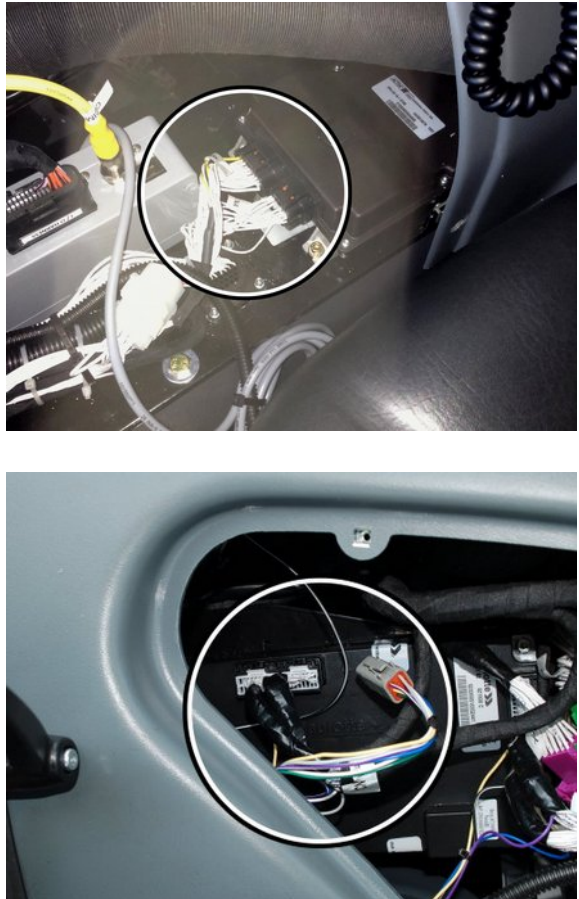
If the clip-on ferrites were removed from the CCIM and user control cables. See Appendix B: Reattach Ferrites and page 54 for the correct reattachment position.

# Machine Connections

The following procedures connect the safety systems to the existing electronics in the machine.

 Isolate the main battery before starting the machine connections

 After completing the machine connections the boom can not be moved until the installation is complete

<i>Step</i>	<i>Description</i>	<i>Diagram</i>
1.	<p>The machine connections are attached to the ECU unit underneath the joystick and the ECU unit underneath the dashboard.</p> <p>Crimp the wires from the 4 pin machine input harness to the ECU wires according to the 4 Pin Machine Input Harness Connections table on page 39.</p> <p>Crimp the wires from the 2 pin stabiliser harness to the ECU wires according to the 2 Pin Stabiliser Harness Connections table on page 40.</p>	


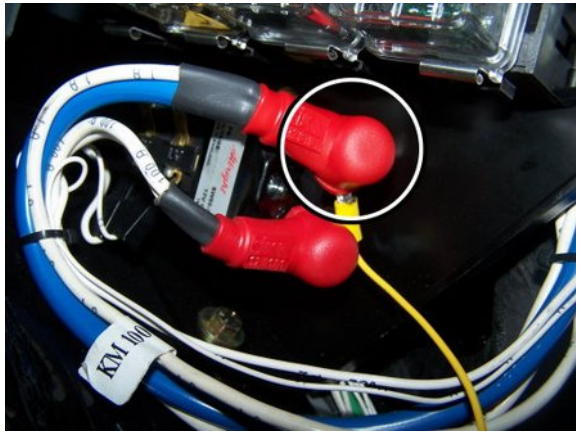
<i>Step</i>	<i>Description</i>	<i>Diagram</i>
2.	Crimp the wires from the 3 pin connector to the wires from the PF connector according to PF Connector table on page 40.	
3.	Connect the ring lug from the 3 pin connector to the positive battery terminal connection KM100 below the fuse panel.  Note: This is connected to the blue cable	

Table 17: Machine Connections

## 4 Pin Machine Input Harness Connections

<i>4 Pin Connector</i>	<i>ECU Connector</i>	<i>ECU Location</i>	<i>Wire Number</i>	<i>Wire Colour</i>
1	A.22	Under Joystick	Splice Into B113	Grey
2	A.23	Under Joystick	Splice Into B114	White
3	B.16	Under Joystick	B108 To Switch	Yellow
4	B.16	Under Joystick	B108 To ECU	Violet

Table 18: 4 Pin Machine Input Harness Wiring Diagram

## 2 Pin Stabiliser Harness Connections

<i>2 Pin Connector</i>	<i>ECU Connector</i>	<i>ECU Location</i>	<i>Wire Number</i>	<i>Wire Colour</i>
1	104.5	Under Dashboard	Splice Into B115	Green
2	104.6	Under Dashboard	Splice Into B116	Blue

*Table 19: 2 Pin Stabiliser Harness Wiring Diagram*

## PF Connector

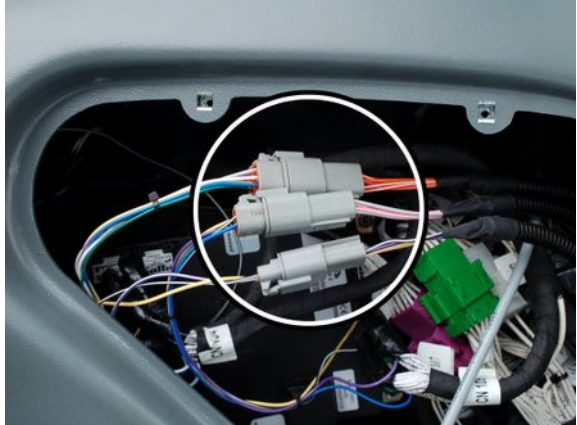


<i>Connector</i>	<i>Wire Number</i>	<i>Wire Colour</i>
PF	0	Black
PF	195	Violet

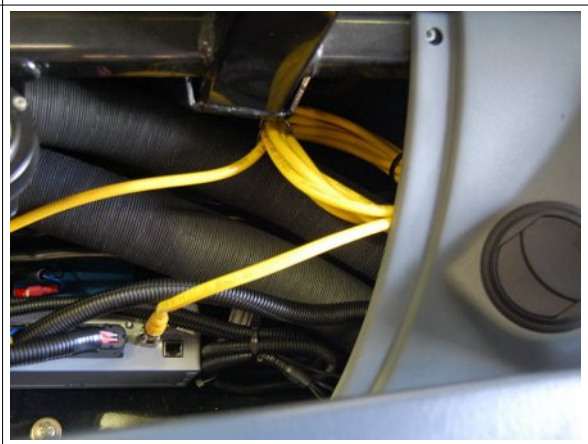


*Table 20: PF Connector Wiring Diagram*



# Finalisation

This section will complete the final power connections to power the system and finish any additional items.

<i>Step</i>	<i>Description</i>	<i>Diagram</i>
1.	<p>Connect the 4 pin and 3 pin connectors into the cabin loom.</p> <p>Connect the 6 pin connector from the cutout harness to the cabin loom.</p> <p>Note: The 12 pin on the cabin loom is not used.</p>	
2.	<p>Connect the spade lug on the black wire to the negative (black) battery terminal.</p> <p>Connect the spade lug on the blue wire to the positive (red) battery terminal.</p>	
3.	<p>Attach the backup battery and CCIM to the velcro strips installed earlier.</p>	

<i>Step</i>	<i>Description</i>	<i>Diagram</i>
4.	Coil up the extra cable from the CCIM, signal light and camera cables and store behind the cover towards the back of the cabin.	
5.	Plug in the height limiter connections back into YV300, YV320 and YV340 at the rear of the machine	
6.	<p>Reconnect the main battery from the isolation switch.</p> <p>Turn the machine onto first stage /accessories and ensure the system is activated.</p>	


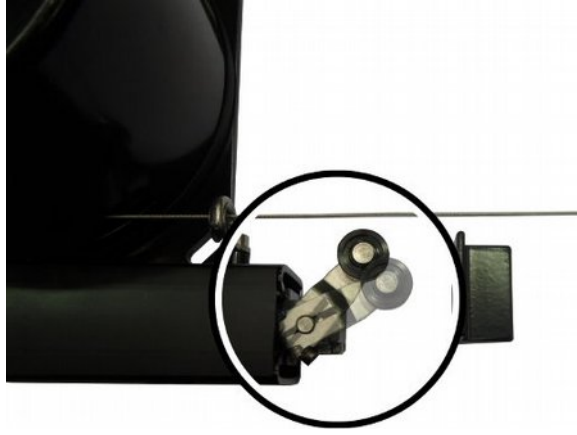


<i>Step</i>	<i>Description</i>	<i>Diagram</i>
7.	<p>Adjust the display bracket for optimal viewing</p> <p>Set the machine into forward gear to activate the forward camera. Adjust the forward camera so the front right wheel is visible.</p> <p>Set the machine into reverse gear to activate the reverse camera. Adjust the reverse camera so the video is level.</p>	
8.	<p>Operate the boom movement controls to test if a false N07 fault occurs.</p> <p>If a N07 fault does occur, adjust the arm on the stow switch forwards towards the stow switch trigger.</p> <p>Note: The actual switch arm orientation may differ from the picture.</p>	
9.	<p>Perform a final check on all the cabling and sensors.</p> <p>Replace all the covers</p>	


Table 21: Finalisation



Complete the system checklist once installation has been completed.

# Set Time & Sensor Calibration

Once the installation is complete, the time will need to be set and the sensors will require calibration.



A sensor calibration must be performed once the cable reeler and CPIM have been mounted. If the cable reeler or CPIM have been moved/repositioned a recalibration must be performed

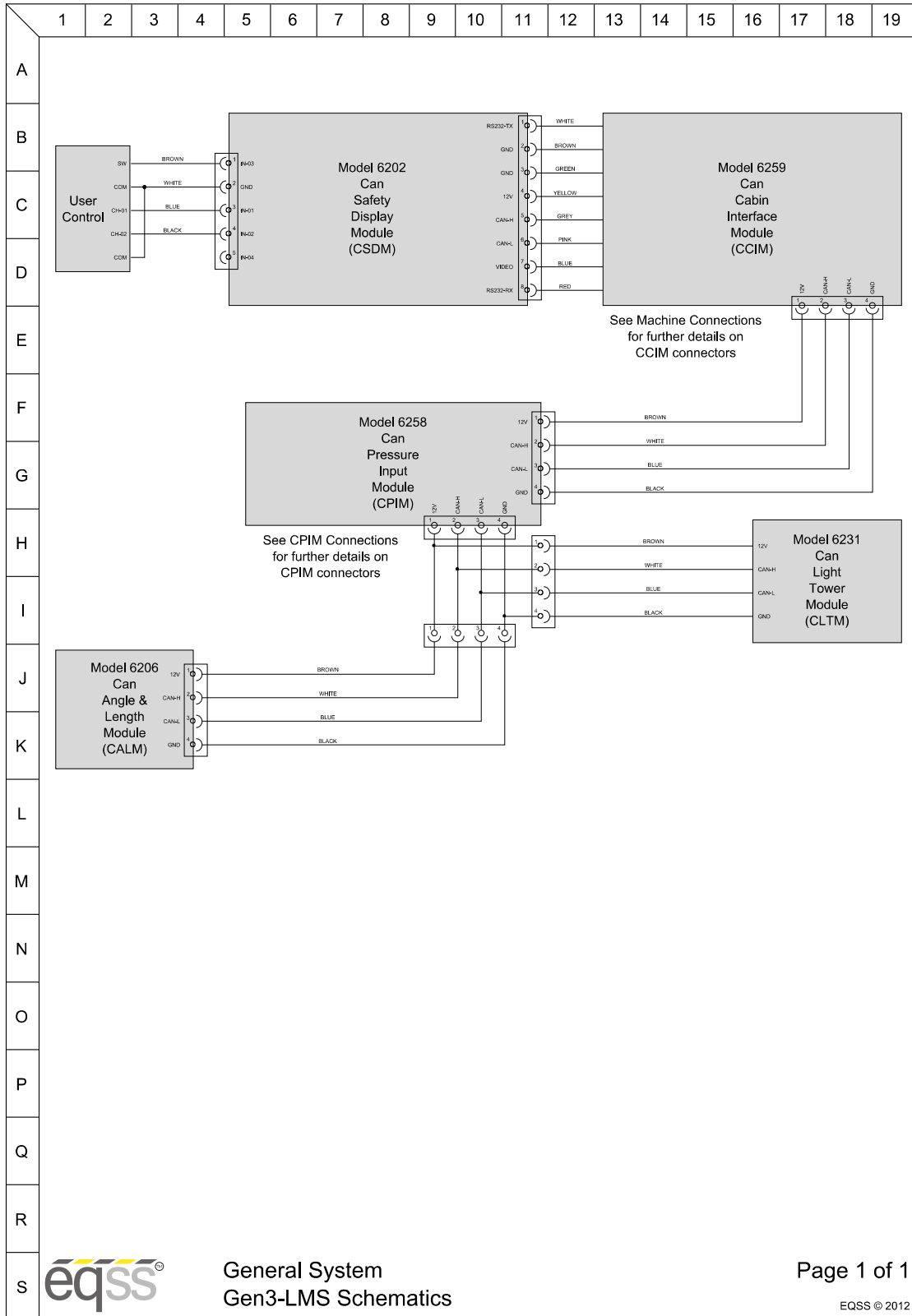
<i>Step</i>	<i>Description</i>	<i>Diagram</i>
1.	<p>Press Enter on the user control dial to enter the menu system.</p> <p>Press the arrow buttons to select System Menu.</p> <p>Press Enter to select the menu.</p>	<hr/> <p style="font-size: small;">Main Menu</p> <hr/> <p>Attachment Selection Menu</p> <hr/> <div style="background-color: #4a7ebb; color: white; padding: 5px; text-align: center; font-weight: bold;">System Menu</div> <hr/> <p>Exit Menu</p> <hr/>
2.	<p>Select Advanced Menu</p>	<hr/> <p style="font-size: small;">System Menu</p> <hr/> <p>Volume / Brightness</p> <hr/> <p>Status Menu</p> <hr/> <p>Diagnostics Menu</p> <hr/> <p>System Tests</p> <hr/> <div style="background-color: #4a7ebb; color: white; padding: 5px; text-align: center; font-weight: bold;">Advanced Menu</div> <hr/> <p>Return to Main Menu</p> <hr/>

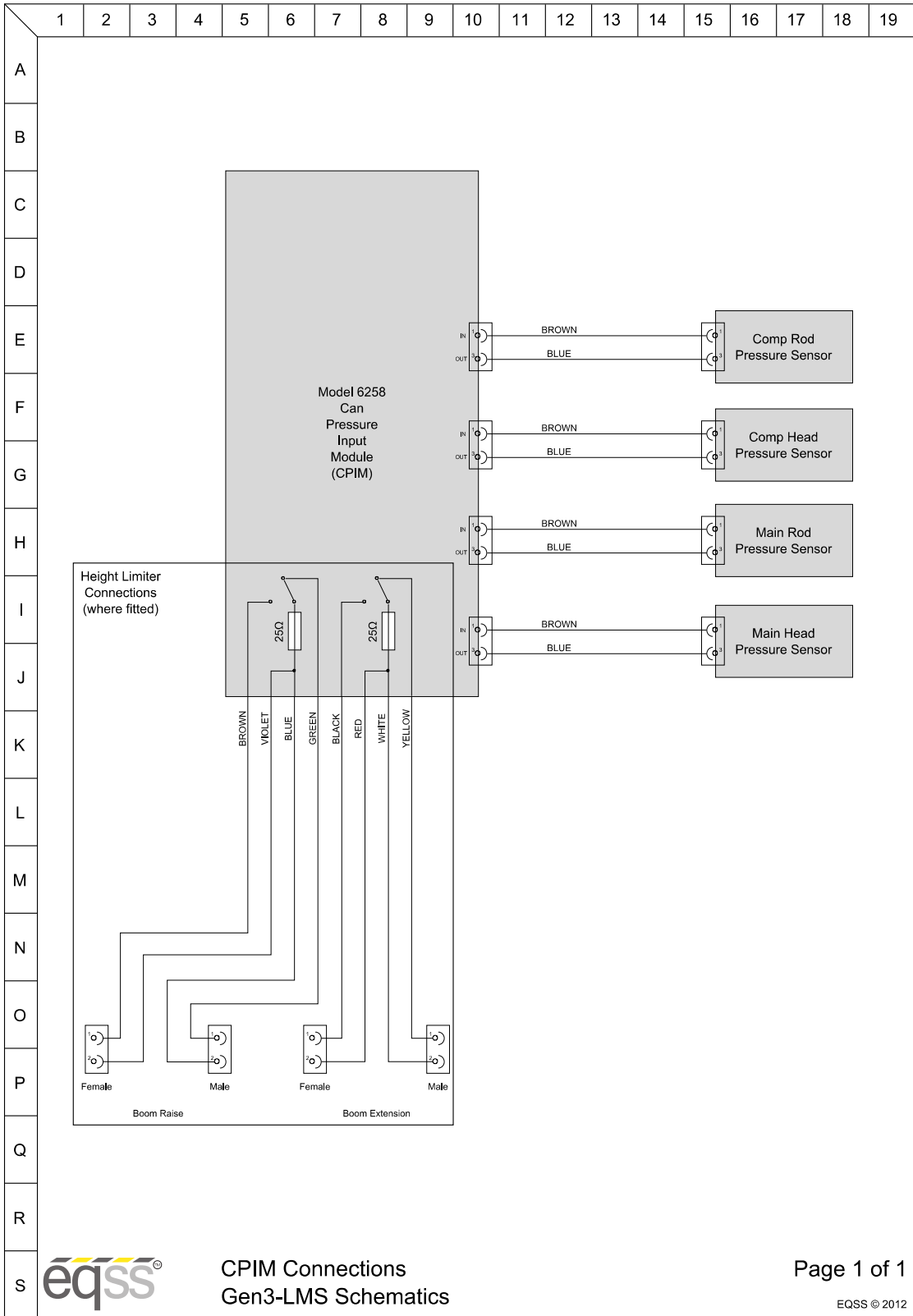
<i>Step</i>	<i>Description</i>	<i>Diagram</i>														
3.	Enter the password (Default Password: 2-8-4)	<table border="1"> <thead> <tr> <th colspan="2"><b>Enter Password</b></th> </tr> </thead> <tbody> <tr> <td>Number 1</td> <td>2</td> </tr> <tr> <td>Number 2</td> <td>8</td> </tr> <tr> <td>Number 3</td> <td>4</td> </tr> <tr> <td colspan="2"><b>Submit Password</b></td> </tr> <tr> <td colspan="2">Return to System Menu</td> </tr> </tbody> </table>	<b>Enter Password</b>		Number 1	2	Number 2	8	Number 3	4	<b>Submit Password</b>		Return to System Menu			
<b>Enter Password</b>																
Number 1	2															
Number 2	8															
Number 3	4															
<b>Submit Password</b>																
Return to System Menu																
4.	Select Set Time / Date	<table border="1"> <thead> <tr> <th colspan="2"><b>Advanced Settings</b></th> </tr> </thead> <tbody> <tr> <td colspan="2"><b>Set Time / Date</b></td> </tr> <tr> <td colspan="2">Sensor Calibrations</td> </tr> <tr> <td colspan="2">Change Language</td> </tr> <tr> <td colspan="2">Change Password</td> </tr> <tr> <td colspan="2">Return to System Menu</td> </tr> </tbody> </table>	<b>Advanced Settings</b>		<b>Set Time / Date</b>		Sensor Calibrations		Change Language		Change Password		Return to System Menu			
<b>Advanced Settings</b>																
<b>Set Time / Date</b>																
Sensor Calibrations																
Change Language																
Change Password																
Return to System Menu																
5.	<p>Enter the correct time and date for your area.</p> <p>Press the arrow keys to select a time/date parameter</p> <p>Press Enter and the parameter will change to red, press the arrow keys to change the value and then press the Enter key to store the value.</p> <p>Note: The hour parameter is in 24 hour clock</p> <p>Repeat for the rest of the time values</p>	<table border="1"> <thead> <tr> <th colspan="2"><b>Set Time / Date</b></th> </tr> </thead> <tbody> <tr> <td><b>Hour</b></td> <td><b>15</b></td> </tr> <tr> <td>Minute</td> <td>54</td> </tr> <tr> <td>Day</td> <td>10</td> </tr> <tr> <td>Month</td> <td>2</td> </tr> <tr> <td>Year</td> <td>2016</td> </tr> <tr> <td>Region</td> <td>Melbourne</td> </tr> </tbody> </table>	<b>Set Time / Date</b>		<b>Hour</b>	<b>15</b>	Minute	54	Day	10	Month	2	Year	2016	Region	Melbourne
<b>Set Time / Date</b>																
<b>Hour</b>	<b>15</b>															
Minute	54															
Day	10															
Month	2															
Year	2016															
Region	Melbourne															

<i>Step</i>	<i>Description</i>	<i>Diagram</i>
6.	Scroll to the next page and select Save to store the new time/date and return to the Advanced Menu.	
7.	Select Sensor Calibrations	
8.	Select Calibrate Carrier Angle and then follow the instructions on the screen to complete the calibration.  Repeat for Calibrate Boom Angle and Calibrate Boom Length.	

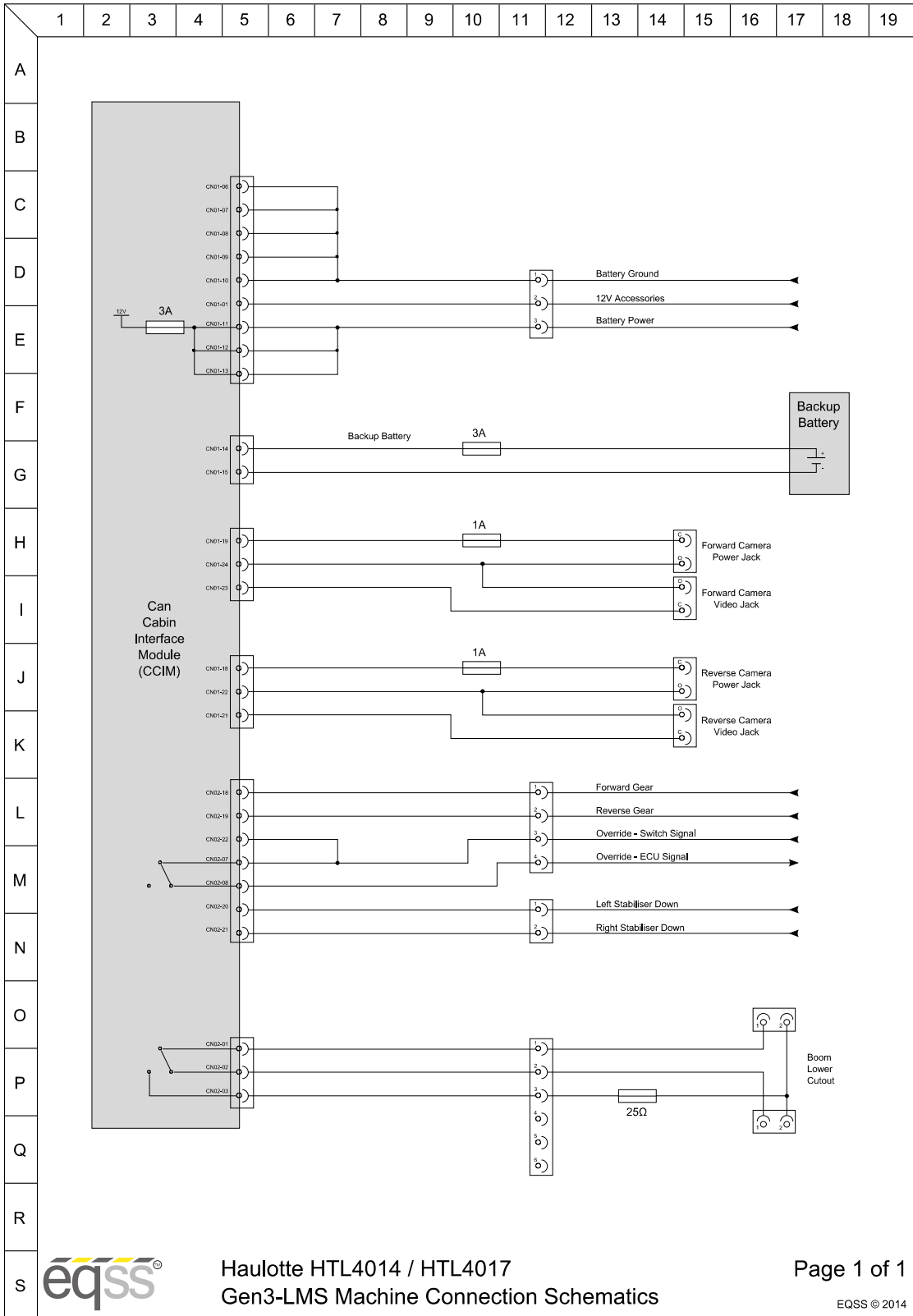
Table 22: Sensor Calibration

# Schematics









# Appendix A: Attaching Display Connectors

The procedure below describes the correct method of attaching the cables to the screw lock connectors on the display.



If the M12 screw lock connectors on the display are over tightened, it will twist the connector pins attaching the connector to the PCB.

<i>Step</i>	<i>Description</i>	<i>Diagram</i>
1.	<p>Connect the cable from the user control to the top 5 pin connector on the display.</p> <p>Connect the cable from the CCIM to the bottom 8 pin connector on the display.</p>	
2.	<p>Line up the alignment hole on the cable connector with the alignment notch on the display connector.</p>	




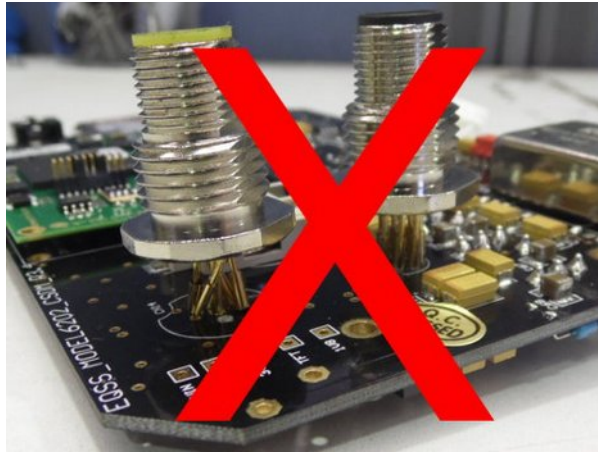
<i>Step</i>	<i>Description</i>	<i>Diagram</i>
3.	Push the female connector from the cable into the male connector on the display.	
4.	Rotate the nut on the female connector by hand in a clockwise direction, until the tension on the nut starts to increase.	
5.	Push the cable in again and repeat steps 3 and 4 until the connector is secure.	

Table 23: Install Display Connector Procedure



The method to correctly secure the cable is to push-twist-push-twist until the connector is fully inserted and secure. This will minimise the twisting force applied to the connector.

Below is a picture of a damaged connector on the PCB inside the display. This damaged occurred because the connector was over tightened.



*Illustration 7: Damaged Display Connector*



Do not use any tools to tighten the connector.



*Illustration 8: Do Not Use Tools To Tighten Connector*



Do not over-tighten the nuts on the back of the display connectors. These nuts should only be hand tightened. If the nuts are overtightened it will damage the PCB inside the display.




*Illustration 9: Do Not Over Tighten Nuts*



Damage to the display connectors is not covered under warranty.

# Appendix B: Reattach Ferrites

If the clip-on ferrites on the displays are removed during installation, they will need to be reattached as shown in the procedure below.

 If the ferrites are not reinstalled or attached in the specified location the Gen3-LMS kit will not meet the AS/NZS CISPR 22:2006 certification.

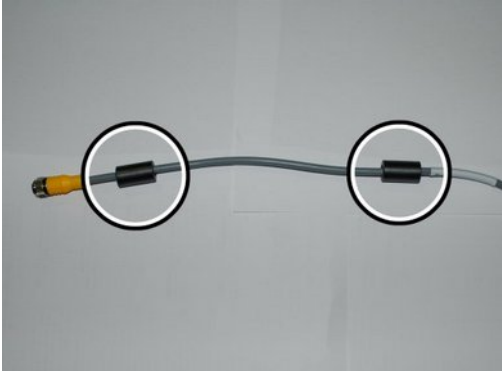
<i>Step</i>	<i>Description</i>	<i>Diagram</i>
1.	<p>Attach the two clip-on ferrites at a location of 60 mm and 260 mm from the start of the connector to the start of the ferrite.</p> <p>Do this for both the CCIM and user control cables that plug into the display.</p>	

Table 24: Reattach Ferrites Procedure

# Indexes and Tables

## Illustration Index

Illustration 1: Machine Boom.....	8
Illustration 2: Machine Chassis.....	9
Illustration 3: Rear of Machine.....	10
Illustration 4: Cabin.....	11
Illustration 5: Cable Reeler Mounting Position.....	15
Illustration 6: Pressure Manifold Components.....	18
Illustration 7: Damaged Display Connector.....	52
Illustration 8: Do Not Use Tools To Tighten Connector.....	52
Illustration 9: Do Not Over Tighten Nuts.....	53

## Index of Tables

Table 1: Component Installation Index.....	7
Table 2: Cable Installation Index.....	7
Table 3: Cover removal.....	12
Table 4: Cable Reeler Installation.....	14
Table 5: Pressure Manifold Installation.....	17
Table 6: Compensation Pressure Sensor Installation.....	19
Table 7: Reverse Camera Installation.....	21
Table 8: Forward Camera Installation.....	23
Table 9: Signal Light Installation.....	26
Table 10: Can Pressure Input Module (CPIM) Installation.....	28
Table 11: Cutout Harness Installation.....	29
Table 12: External Cable Completion.....	31
Table 13: Display Installation.....	32
Table 14: User Input Control Installation.....	33
Table 15: CCIM Installation.....	34
Table 16: Cabin Loom Installation.....	36
Table 17: Machine Connections.....	39
Table 18: 4 Pin Machine Input Harness Wiring Diagram.....	39
Table 19: 2 Pin Stabiliser Harness Wiring Diagram.....	40
Table 20: PF Connector Wiring Diagram.....	40
Table 21: Finalisation.....	43
Table 22: Sensor Calibration.....	46
Table 23: Install Display Connector Procedure.....	51
Table 24: Reattach Ferrites Procedure.....	54

---

**Equipment Safety Systems Pty. Ltd.** ABN: 31 061 789 151  
27 Cumberland Drive, Seaford 3198, Victoria, Australia

Tel: +61 3 8770 6555  
Fax: +61 3 8770 6590  
Web: [www.eqss.com.au](http://www.eqss.com.au)