

# EQSS Model6253 – OverWatch Liugong LSxxxxE Series



**\*\* Failure to follow this installation manual will void warranty \*\***



REV 1.0

18/03/2026

Model6253 OverWatch Installation Manual

Document # DO001819

**AUTHORS:**

Bhavani Kacharapu

**AUTHORISED BY:**

Kieren Grogan

**CHECKED BY:**

Andrew Donegan

**DOCUMENT ABSTRACT:**

This Installation Manual details the instructions for installing the Model6253 OverWatch on a Liugong LSxxxxE Series electric slab scissor lift.

**PRODUCT NAME:**

Model6253 OverWatch Operator Detection System

**REFERENCE DOCUMENTS:**

DO0001195 Model6253 OverWatch User Manual

**CURRENT DOCUMENT REVISION:**

1.0

**REVISION INFORMATION:**

- 1.0 Initial Document Creation for installation on a Liugong LSxxxxE Series control box

## Important Information

Information contained in this publication regarding this device's applications and the like, is provided only for your convenience and may be superseded by updates. It is your responsibility to ensure that the application or our equipment meets with your specifications.

EQUIPMENT SAFETY SYSTEMS MAKE NO REPRESENTATIONS OR WARRANTIES OF ANY KIND, WHETHER EXPRESSED OR IMPLIED, WRITTEN OR ORAL, STATUTORY OR OTHERWISE, RELATED TO THE INFORMATION, INCLUDING, BUT NOT LIMITED TO, IT'S CONDITION, QUALITY, PERFORMANCE, MERCHANTABILITY OR FITNESS FOR PURPOSE.

Equipment Safety Systems disclaims all liability arising from this information and its use. Use of Equipment Safety Systems' products as critical components in life support systems is not authorised except with express written approval by Equipment Safety Systems. No licenses are conveyed, implicitly or otherwise, under any Equipment Safety Systems intellectual property rights.



N23041

This is a class A product certified to AS/NZS CISPR 22:2006. In a domestic environment this product may cause radio interference in which case the user may be required to take adequate measures.



## Table of Contents

Preparation .....	5
Required Tools .....	5
Installation Time .....	5
Installation Instructions .....	6
Operator Sensor .....	6
Control Module .....	8
Post Installation Configuration .....	13
Overview .....	13
Minimum system requirements .....	13
Wi-Fi Connection & Web Page Access .....	13
Machine Model Selection .....	14
Installation Test.....	15
Change Model Configuration .....	15
Harness Drawing AS002221.....	16
Replacement Parts.....	17

## Preparation

### Required Tools

The OverWatch has been designed to be fitted using basic workshop tools. Shown below is a list of tools required to complete the installation

Item	Tool / Description
1	Electric Drill
2	Centre punch
3	Hammer
4	Side Cutters
5	Drill 3.2mm
6	Drill 5.0mm
7	Step Drill (5 – 30mm)
8	Metric sockets or spanners
9	Needle nose pliers
10	Screw drivers

### Installation Time

The suggested time required to install the OverWatch is as detailed below

Task	Estimated Time (Minutes)
Drilling of all mounting holes for the various components	10
Mechanical assembly	5
Electrical assembly	10
Post installation system tests	10
<b>Total</b>	<b>35</b>

# Installation Instructions

## Operator Sensor

Step	Description	Diagram
1.	Remove the Joystick controller from the metal housing.	
2.	Drill three <b>5.2mm</b> holes into the metal housing in the position as shown in the image. These holes are required to mount the operator sensor bracket and the P-Clip which supports the operator sensor cable.	
3.	<p>Mount the operator sensor bracket to the metal enclosure using the supplied nuts, bolts and washers.</p> <p>Use the following hardware from the kit.</p> <ul style="list-style-type: none"> <li>2 x M5 x 12mm Countersunk Screw</li> <li>2 x M5 Lock Nuts</li> <li>4 x M5 Washers</li> </ul>	

4.

**Sensor Mounting Guard**

Attach the operator sensor and guard to the mounting bracket at the 45-degree position using the M5 nuts and washers. Make sure that the sensor is on the 7.5-degree angle, such that it is twisted outwards from the joystick controller.

**The 7.5-degree twist is achieved by rotating the sensor inside the assembly and using the bolt hole as show in the image.**

PARTS LIST			
ITEM	QTY	STOCK NUMBER	DESCRIPTION
1	1	AS002326	Sensor Mounting Guard V2
2	1	AS001910	OverWatch Operator Sensor
3	2	FA001174	Washer, Plain, M5, 304 St. St.
4	2	FA001219	Nut, Hex, M5 x 0.8mm, Nylock

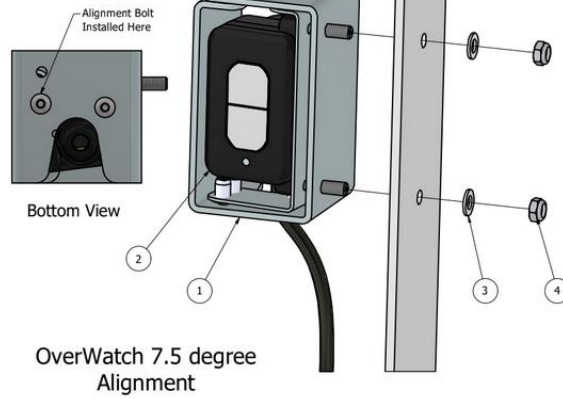



5.



Route the operator sensor cable as shown in the image. Use a P-Clip to secure the cable to the metal enclosure.

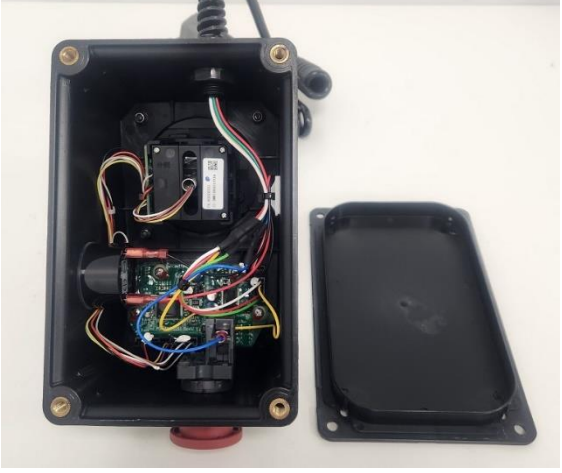

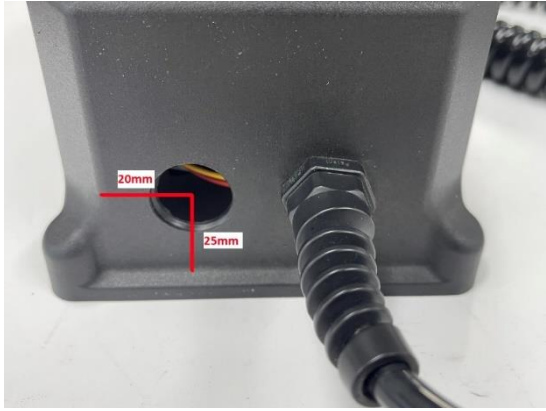
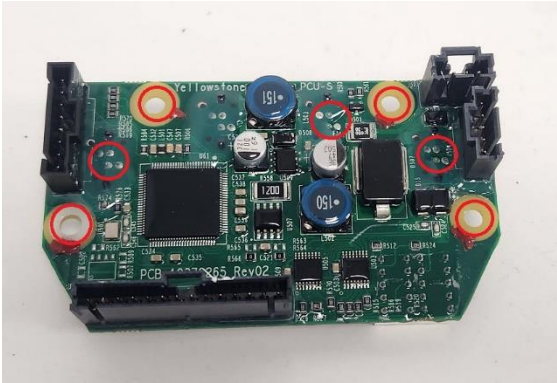
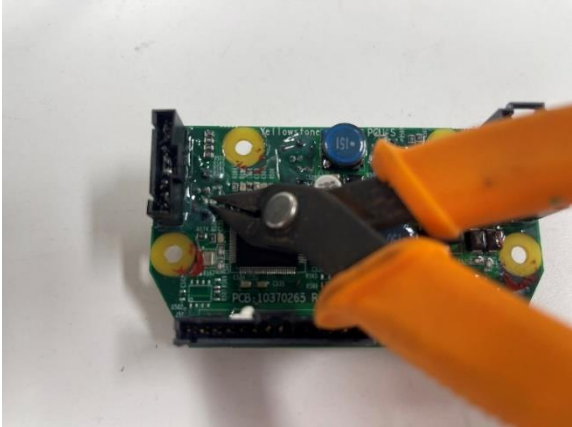

## Control Module

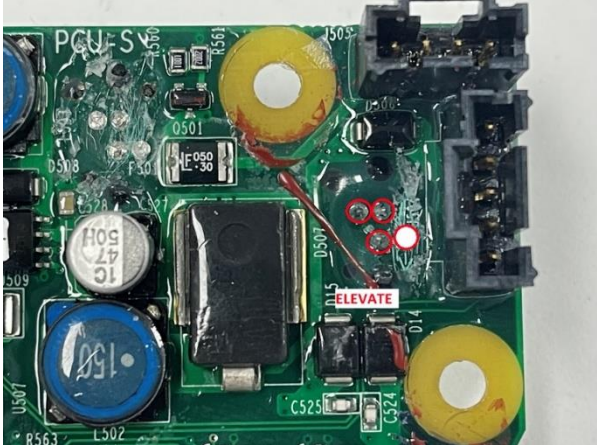
Step	Description	Diagram
1.	Remove the bottom plastic cover from the Joystick to expose the inside wiring and electronics.	
2.	Remove the Buzzer, E-Stop, and the controller circuit board from the plastic enclosure.	

<p>3.</p>	<p>Drill a 20mm hole to run the operator sensor M20 Gland into the plastic joystick enclosure. The position of the hole is detailed as in the image. It is recommended to use a step drill for this hole, as it is running through plastic material.</p>	
<p>4.</p>	<p>Use a fine metal pick to clean the area shown in the red circles, on the adjacent image, to allow access to the pins. This process removes the conformal coating on the PCB and allows electrical access to the drive, elevate and horn connections on the circuit joystick board.</p>	
<p>5.</p>	<p>Use a fine pair of side cutters to trim down the signal pins. These connections must be trimmed to be as flat as possible so that the spring pin from the plug and play board can make suitable contact with the terminal</p>	

<p>6.</p>	<p>Trim down the <b>Elevate</b> signal pin. This pin is located as displayed in the image. Using a fine pair of side cutters make sure that the pin is trimmed flat.</p>	
<p>7.</p>	<p>Trim down the <b>Drive</b> signal pin. This pin is located as displayed in the adjacent image. Using a fine pair of side cutters make sure that the pin is trimmed flat.</p>	
<p>8.</p>	<p>Trim down the two <b>Horn</b> signal pins. These pins are located as displayed in the adjacent image. Using a fine pair of side cutters make sure that the pins are trimmed flat.</p>	

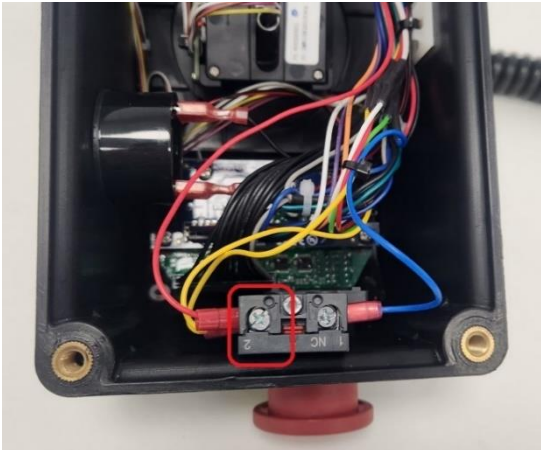
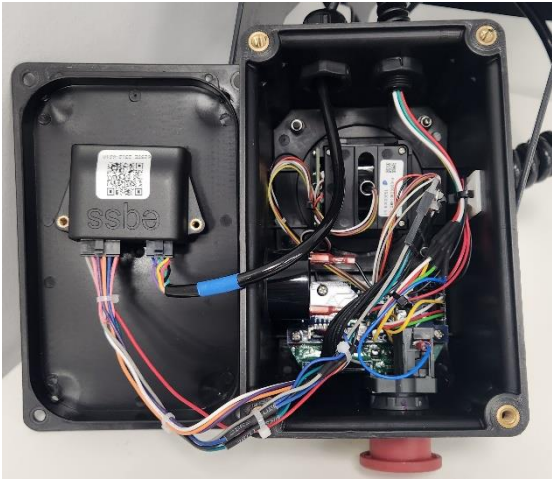
<p>9.</p>	<p>Wiring connections are made with the AS002221 harness.</p>	
<p>10.</p>	<p>Mount the Overwatch circuit board on top of joystick circuit board. Using the provided screws and spacers in the kit. Make sure that the board is sitting in the correct position and the spring pins are contacting the joystick circuit board signal pins. Use the cut-outs next to each spring pin to inspect that the contact is solid with the joystick board.</p>	
<p>11.</p>	<p>Install the Overwatch joystick connectors in between the joystick and the control box circuit board.</p> <p>Visually check that all pins from the original joystick connector have a corresponding cable on the Overwatch harness.</p> <p>Reconnect the other connectors, which were disconnected in step 1 to the control box circuit board.</p>	

<p>12.</p>	<p>At the back of the Estop, install the OverWatch Red Power cable to terminal 2 of the E-Stop. Same terminal as where the yellow wires are connected.</p> <p><i>Note: this cable might need to be changed to terminal 1 if the Overwatch is powered with the E-stop pushed in.</i></p>	
<p>13.</p>	<p>Mount the OverWatch ECU inside the joystick control box, the ECU is mounted to the bottom plastic using the adhesive Velcro tape.</p> <p>Run the operator sensor cable through the predrilled 20mm hole and secure the cable gland.</p> <p>Connect the 8-pin connector from the operator sensor and the 12-pin connector from the overwatch loom to the ECU.</p>	
<p>14.</p>	<p>Re-assemble the joystick control box and mount to the metal shroud.</p> <p>Make sure the operator sensor cable runs clear to the joystick enclosure and tighten the M20 gland to seal the cable entry point.</p>	

# Post Installation Configuration

## Overview

After the system has been installed it must be configured with the parameters to suit the machine. Follow the instructions below to configure the OverWatch.

## Minimum system requirements

Any smart phone, tablet or laptop that meets the following requirements:

- The device can connect to a Wi-Fi access point
- The device has an up to date web browser installed. Firefox, Chrome or Safari are recommended.

## Wi-Fi Connection & Web Page Access

To enable the Wi-Fi connection on the OverWatch to complete the configuration follow the steps below.

1. Power down the platform control box with the ESTOP
2. Wait 5 seconds
3. Power up the platform control box with the ESTOP
4. While standing **in front of the operator sensor**, switch on the OverWatch
5. As the welcome chime starts to play, cover the sensor. The LED will flash white then black to acknowledge.
6. Remove your hand from the sensor. The LED will flash white then black to acknowledge.
7. After covering then uncovering the sensor this way 2 more times, "Wi-Fi On" will be announced
8. On your Wi-Fi enabled device (laptop, tablet, smartphone, etc), show the available wireless networks
9. Select the wireless network (starts with "overwatch") to connect to the OverWatch
10. When prompted, enter the **password 12345678**
11. Open your preferred web browser (Chrome, Firefox, Safari)
12. Enter the following into the address bar <http://192.168.4.1> to open the OverWatch main page

## Machine Model Selection

Follow the instructions below to configure the OverWatch.

1. Select the Setup option
2. If there is a password field at the bottom of the page, follow the instructions in Change Model Configuration to obtain the password and enter the password field
3. Select the EWP Model from the drop-down list and click Set
4. Click on Proceed to test to begin the installation test

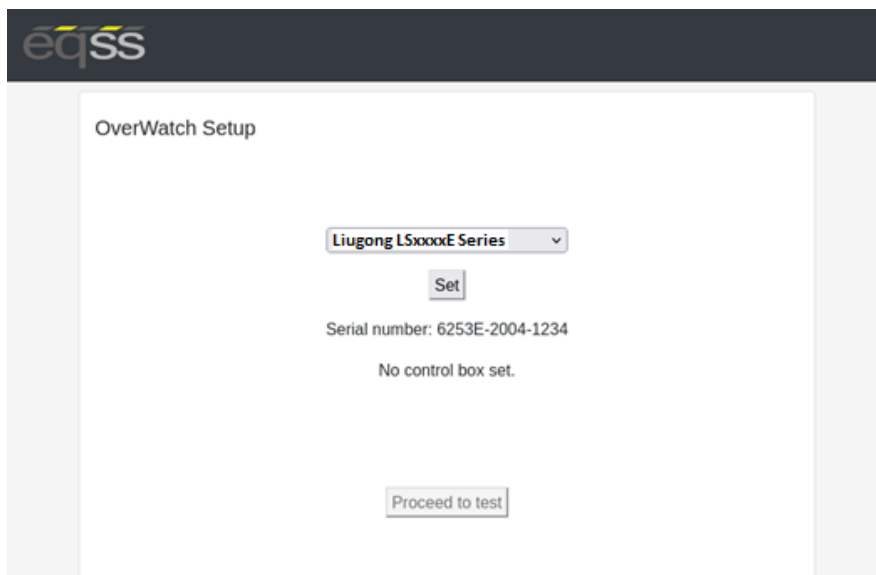

OverWatch Setup

Liugong LSxxxxE Series

Set

Serial number: 6253E-2004-1234

No control box set.

Proceed to test

## Installation Test

After the model configuration has been set or updated an Installation Test must be performed. This will ensure the installation has been correctly performed and the OverWatch is functioning correctly. Follow the instructions on the web page to complete the Installation Test.

## Change Model Configuration

To reconfigure the OverWatch for a different model requires an authorisation password. The authorisation password is generated from the EQSS website. The EQSS website requires a login username and password, contact EQSS for these details.

Follow the instructions below to obtain an authorisation password. It is important to note that each ECU has a unique serial number and a unique password.

1. Open your web and enter the following into the address bar <http://www.eqss.com.au/overwatch> to open the Login page
2. Enter your username and password
3. Enter the EUC serial number which is shown on the setup page or on the ECU serial number sticker, also enter the owner and model details of the EWP and then click Generate Hash
4. The generated Hash code or password can be used to change the model configuration.

# Harness Drawing AS002221

Rev	Date	Author	Description
1.0	13/09/22	Andrew Donegan	Initial Design
1.1	20/09/2022	Andrew Donegan	Include all link wires on the 14 pin connectors

Final Assembly Photo: <https://drive.google.com/file/d/11WwXqdzm5TnDpchoV0p4ort1-c9UD65/view>  
Please Note: The Photo Shown Has The PCB Connected To The Loose Wires

From	To	Conductor	Color	Gauge	Notes
C1_LOW.1	ST1_PWR	W25	Red	22 AWG	OW_PWR
C1_LOW.2	S1_GND1	W1	Black	22 AWG	OW_GND
C1_LOW.3	S2_DM.IN	W19	Green	22 AWG	OW_DM_SS
C1_LOW.4	S7_LOOP.1	W29	Pink	24 AWG	OW_DM_ECU1
C1_LOW.4	S8_LOOP.2	W30	Pink	24 AWG	OW_DM_ECU2
C1_LOW.5	W4_HORN	W24	White	22 AWG	OW_HORN
C1_LOW.7	S7_LOOP.1	W26	Pink	24 AWG	OW_AUX.IN
C1_LOW.8	S3_DM.OUT	W18	Blue	22 AWG	OW_AUX.OUT
C1_LOW.9	W5_ELE	W22	Orange	22 AWG	OW_ELE
C1_LOW.10	W6_DRV	W23	Violet	22 AWG	OW_DRV
C1_LOW.11	S8_LOOP.2	W27	Pink	24 AWG	OW_TEST
C1_LOW.12	S5_JOY	W13	Gray	22 AWG	OW_JOY

From	To	Conductor	Color	Gauge	Notes
S1_GND1	C1_LOW.2	W1	Black	22 AWG	OW_GND
S1_GND1	W3_GND	W3	Black	22 AWG	PCB_GND
S1_GND1	S4_GND2	W2	Black	22 AWG	GND_LINK
S2_DM.IN	C1_LOW.3	W19	Green	22 AWG	OW_DM_SS
S2_DM.IN	W2_DM.IN	W20	Green	22 AWG	CONN_DM.IN
S3_DM.OUT	C1_LOW.8	W18	Blue	22 AWG	OW_AUX.OUT
S3_DM.OUT	W3_DM.OUT	W17	Blue	22 AWG	CONN_DM.OUT
S4_GND2	C2_TM.13	W4	Black	22 AWG	GND_M
S4_GND2	S1_GND1	W2	Black	22 AWG	GND_F
S5_JOY	C1_LOW.12	W13	Gray	22 AWG	OW_JOY
S5_JOY	C2_TM.11	W14	Gray	22 AWG	JOY_M
S5_JOY	C3_TF.1	W15	Gray	22 AWG	JOY_F

From	To	Conductor	Color	Gauge	Notes
C2_TM.1	S5_JOY	W14	Gray	22 AWG	JOY_M
C2_TM.2	C3_TF.2	W6	Black	22 AWG	CONN_LINK.2
C2_TM.3	C3_TF.3	W7	Black	22 AWG	CONN_LINK.3
C2_TM.4	C3_TF.4	W8	Black	22 AWG	CONN_LINK.4
C2_TM.5	S2_DM.IN	W21	Green	22 AWG	CONN_DM.IN
C2_TM.6	C3_TF.6	W9	Black	22 AWG	CONN_LINK.6
C2_TM.7	C3_TF.7	W10	Black	22 AWG	CONN_LINK.7
C2_TM.8	C3_TF.8	W11	Black	22 AWG	CONN_LINK.8
C2_TM.9	C3_TF.9	W11	Black	22 AWG	CONN_LINK.9
C2_TM.10	C3_TF.10	W12	Black	22 AWG	CONN_LINK.10
C2_TM.11	C3_TF.11	W12	Black	22 AWG	CONN_LINK.11
C2_TM.12	C3_TF.12	W13	Black	22 AWG	CONN_LINK.12
C2_TM.13	S4_GND2	W4	Black	22 AWG	GND_M
C2_TM.14	C3_TF.14	W28	Black	22 AWG	CONN_LINK.14

Part Number	Quantity
CN001316	1
CN001364	1
CN001366	1
CN001331	1
CN001365	14
CN001367	14
CN001114	1
CB001087	1520 mm
CB001088	310 mm
CB001091	360 mm
CB001090	360 mm
CB001095	250 mm
CB001098	250 mm
CB001099	250 mm
CB001089	250 mm
CB001116	100 mm

From	To	Conductor	Color	Gauge	Notes
C3_TF.1	S5_JOY	W15	Gray	22 AWG	JOY_F
C3_TF.2	C2_TM.2	W6	Black	22 AWG	CONN_LINK.2
C3_TF.3	C2_TM.3	W7	Black	22 AWG	CONN_LINK.3
C3_TF.4	C2_TM.4	W8	Black	22 AWG	CONN_LINK.4
C3_TF.5	S3_DM.OUT	W18	Blue	22 AWG	CONN_DM.OUT
C3_TF.6	C2_TM.6	W9	Black	22 AWG	CONN_LINK.6
C3_TF.7	C2_TM.7	W10	Black	22 AWG	CONN_LINK.7
C3_TF.8	C2_TM.8	W11	Black	22 AWG	CONN_LINK.8
C3_TF.9	C2_TM.9	W11	Black	22 AWG	CONN_LINK.9
C3_TF.10	C2_TM.10	W12	Black	22 AWG	CONN_LINK.10
C3_TF.11	C2_TM.11	W12	Black	22 AWG	CONN_LINK.11
C3_TF.12	C2_TM.12	W13	Black	22 AWG	CONN_LINK.12
C3_TF.13	S4_GND2	W4	Black	22 AWG	GND_F
C3_TF.14	C2_TM.14	W28	Black	22 AWG	CONN_LINK.14

From	To	Conductor	Color	Gauge	Notes
W1_GND	S1_GND1	W3	Black	22 AWG	PCB_GND
W2_DM.IN	S2_DM.IN	W20	Green	22 AWG	PCB_DM.IN
W3_DM.OUT	S3_DM.OUT	W17	Blue	22 AWG	PCB_DM.OUT
W4_HORN	C1_LOW.5	W24	White	22 AWG	OW_HORN
W5_ELE	C1_LOW.9	W22	Orange	22 AWG	OW_ELE
W6_DRV	C1_LOW.10	W23	Violet	22 AWG	OW_DRV

From	To	Conductor	Color	Gauge	Notes
ST1_PWR	C1_LOW.1	W25	Red	22 AWG	OW_PWR
S7_LOOP.1	C1_LOW.7	W26	Pink	24 AWG	OW_AUX.IN
S8_LOOP.2	C1_LOW.11	W27	Pink	24 AWG	OW_TEST

From	To	Conductor	Color	Gauge	Notes
W1_GND	S1_GND1	W3	Black	22 AWG	PCB_GND
W2_DM.IN	S2_DM.IN	W20	Green	22 AWG	PCB_DM.IN
W3_DM.OUT	S3_DM.OUT	W17	Blue	22 AWG	PCB_DM.OUT
W4_HORN	C1_LOW.5	W24	White	22 AWG	OW_HORN
W5_ELE	C1_LOW.9	W22	Orange	22 AWG	OW_ELE
W6_DRV	C1_LOW.10	W23	Violet	22 AWG	OW_DRV

Part Number	Revision
A3002196	1.1

Name	Date
A. Donegan	20/09/22
K. Grogan	20/09/22
A. Donegan	20/09/22
K. Grogan	20/09/22

Drawn By: A. Donegan  
Eng Approved: K. Grogan  
Mfg Approved: A. Donegan  
QA: K. Grogan

File: Wire Harness  
Description: Overwatch DataTech P500 Plug & Play Harness

Notes

- Small Cable Tie Here
- Strip 5mm and Tin(Solder) All 6 Loose Wires
- Use Two Lengths of Pink 24 AWG Wire Here. Do Not Splice. See Final Assembly Photo For Details
- Seal All Splice Joints Using Glue Heatshrink

## Replacement Parts

Replacement parts for this OverWatch kit are available from EQSS, for all inquiries please email [sales@eqss.com.au](mailto:sales@eqss.com.au)  
Shown below are the part numbers for the major components included in this model specific kit.

Part Number	Description
AS002536	OverWatch - Complete kit for Liugong LSxxxxE Series Control Box
AS001910	OverWatch - Operator Sensor with M20 gland
AS001916	OverWatch - Electronic Control Unit (ECU)
AS002221	OverWatch –Liugong LSxxxxE Series Harness
AS002326	OverWatch - Sensor Guard V2
ME001818	OverWatch – L Bracket 30/45