

EQSS Model6253 – OverWatch JLG ESxxxx Series



**** Failure to follow this installation manual will void warranty ****



REV 1.7

24/03/2026

Model6253 OverWatch Installation Manual

Document # DO001630

AUTHORS:

Kieren Grogan, Bhavani Kacharapu

AUTHORISED BY:

Kieren Grogan

CHECKED BY:

Kieren Grogan

DOCUMENT ABSTRACT:

This Installation manual details the instructions for installing the Model6253 OverWatch on a JLG ESxxxx series scissor lift.

PRODUCT NAME:

Model6253 OverWatch Operator Detection System

REFERENCE DOCUMENTS:

DO001195 Model6253 OverWatch - User Manual

CURRENT DOCUMENT REVISION:

1.7

REVISION INFORMATION:

- 1.1 Initial Document Creation for installation on a JLG ESxxxx Series
- 1.2 Update to include installation steps for hard wire connections and more detailed installation graphics
- 1.3 Update on installation instructions to suit the Plug and Play Loom AS001930
- 1.4 Update on operator sensor installation instructions and images
- 1.5 Update on config name and system settings
- 1.6 Inclusion of sensor guard V2 and update to model configuration instructions
- 1.7 Update on the installation instructions for the horn connection

Important Information

Information contained in this publication regarding this device's applications and the like, is provided only for your convenience and may be superseded by updates. It is your responsibility to ensure that the application or our equipment meets with your specifications.

EQUIPMENT SAFETY SYSTEMS MAKE NO REPRESENTATIONS OR WARRANTIES OF ANY KIND, WHETHER EXPRESSED OR IMPLIED, WRITTEN OR ORAL, STATUTORY OR OTHERWISE, RELATED TO THE INFORMATION, INCLUDING, BUT NOT LIMITED TO, IT'S CONDITION, QUALITY, PERFORMANCE, MERCHANTABILITY OR FITNESS FOR PURPOSE.

Equipment Safety Systems disclaims all liability arising from this information and its use. Use of Equipment Safety Systems' products as critical components in life support systems is not authorised except with express written approval by Equipment Safety Systems. No licenses are conveyed, implicitly or otherwise, under any Equipment Safety Systems intellectual property rights.



N23041

This is a class A product certified to AS/NZS CISPR 22:2006. In a domestic environment this product may cause radio interference in which case the user may be required to take adequate measures.



Table of Contents

Preparation 5
 Required Tools 5
 Installation Time 5
 Installation Instructions 6
 Operator Sensor 6
 Control Module 11
 Post Installation Configuration 14
 Overview 14
 Minimum system requirements 14
 Wi-Fi Connection & Web Page Access 14
 Machine Model Selection 15
 Installation Test 16
 Change Model Configuration 17
 System Settings 18
 Default Parameters 18
 Polarity and Input Style 19
 Harness Drawing AS001930 20
 Replacement Parts 21

Preparation

Required Tools

The OverWatch has been designed to be fitted using basic workshop tools. Shown below is a list of tools required to complete the installation.

Item	Tool / Description
1	Electric Drill
2	Centre punch
3	Hammer
4	Side Cutters
5	Drill 3.2mm
6	Drill 5.0mm
7	Metric sockets or spanners
8	Needle nose pliers
9	Screw drivers
10	Soldering Iron



Installation Time

The suggested time required to install the OverWatch is as detailed below

Task	Estimated Time (Minutes)
Open the operator control box	2
Drilling of all mounting holes for the various components	15
Mechanical assembly	10
Electrical assembly	15
Post installation system tests	10
Close the operator control box	3
Total	55

Installation Instructions

Operator Sensor

Step	Description	Diagram
1.	Remove the metal mounting bracket attached at the bottom of the control box.	
2.	<p>Drill two 5.2mm holes into the metal housing in the location as shown.</p> <p>These holes are required to mount the operator sensor bracket.</p> <p>Hole 1# - Horizontal distance 20mm, vertical distance 10mm</p> <p>Hole 2# - Horizontal distance 20mm, vertical distance 32.5mm</p>	

3.

Drill one **5.2mm** hole to install the P-clip.

Note: The distance is measured from the centre of the curve edge.



4.

Separate the joystick controller from the metal enclosure.



5. Drill one **20mm** hole to run the operator sensor M20 gland into the metal enclosure. The position of the hole is detailed as in the image.

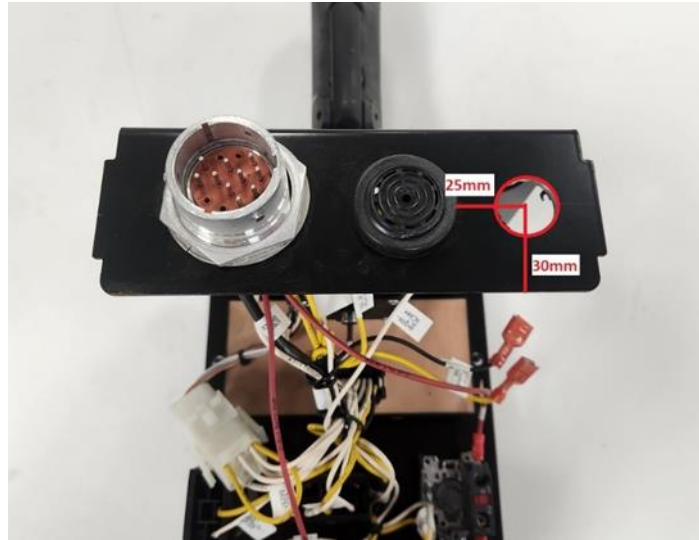

6. **Sensor Mounting Guard V1 (ME001794)**

Mount the operator sensor in the **45-degree position** by using the wedges, sensor guard, bolts and washers.

The orientation of the wedge blocks is critical for the correct positioning of the operator sensor. Make sure that the sensor is angled, such that it is **twisted outwards** from the joystick controller.

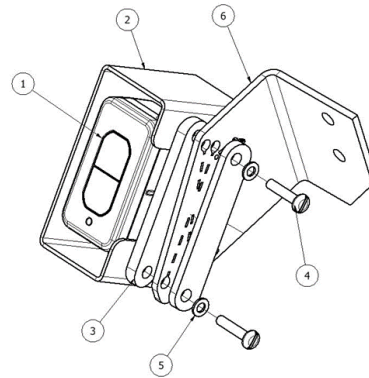

PARTS LIST			
ITEM	QTY	PART NUMBER	DESCRIPTION
1	1	AS001910	OverWatch™ Operator Sensor
2	1	ME001794	OverWatch™ Sensor Guard
3	2	ME001798	OverWatch™ 7.5° Wedge
4	2	FA001422	M4 x 20mm Post Torx Butt Screw
5	2	FA001235	Washer, Plain, M4, 304 St. St.
6	1	ME001818	Operator Sensor Mounting Bracket

7.

Sensor Mounting Guard V2 (AS002326)

This guard (AS002326) supersedes the original V1 design.

Mount the operator sensor in the **45-degree position** on the mounting bracket using the supplied M5 washers and nuts. Make sure that the sensor is on the 7.5-degree angle, such that it is twisted outwards from the joystick controller.

The 7.5-degree twist is achieved by rotating the sensor inside the assembly and using the bolt hole as show in the image.

PARTS LIST			
ITEM	QTY	STOCK NUMBER	DESCRIPTION
1	1	AS002326	Sensor Mounting Guard V2
2	1	AS001910	OverWatch Operator Sensor
3	2	FA001174	Washer, Plain, M5, 304 St. St.
4	2	FA001219	Nut, Hex, M5 x 0.8mm, Nylock

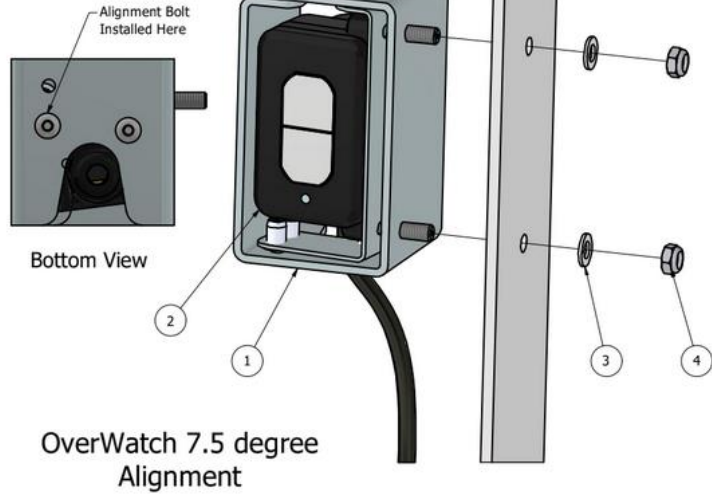

8.

Mount the sensor bracket to the joystick box by using the supplied nuts, bolts, and washers.

Use the following hardware from the kit.

- 2 x M4 x 12mm Bolts
- 2 x M4 Lock Nuts
- 2 x M4 Washers



9.

ECU Module Installation

Drill two **5mm** holes spaced **65mm** apart to install ECU module as shown in the image.

Horizontal distance from the vertical edge to the centre of the hole 1 is **50mm**.

Vertical distance from the bottom edge to the centre of the hole 1 is **115mm**.

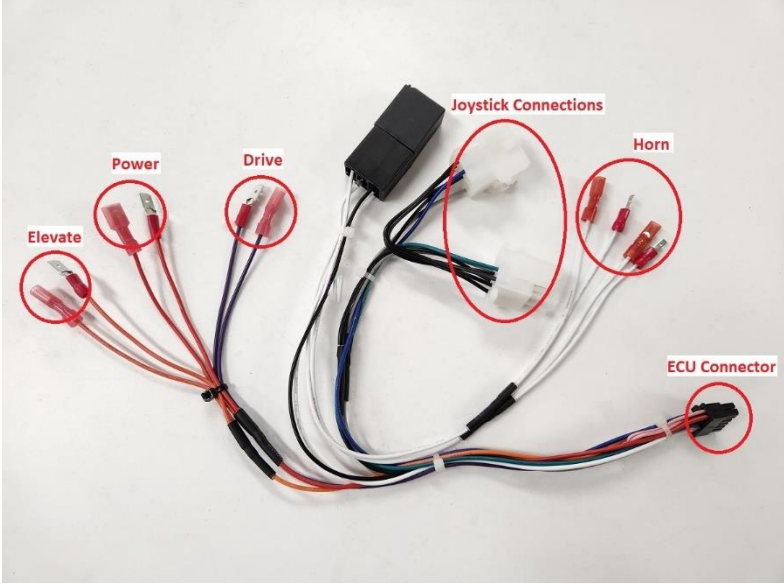
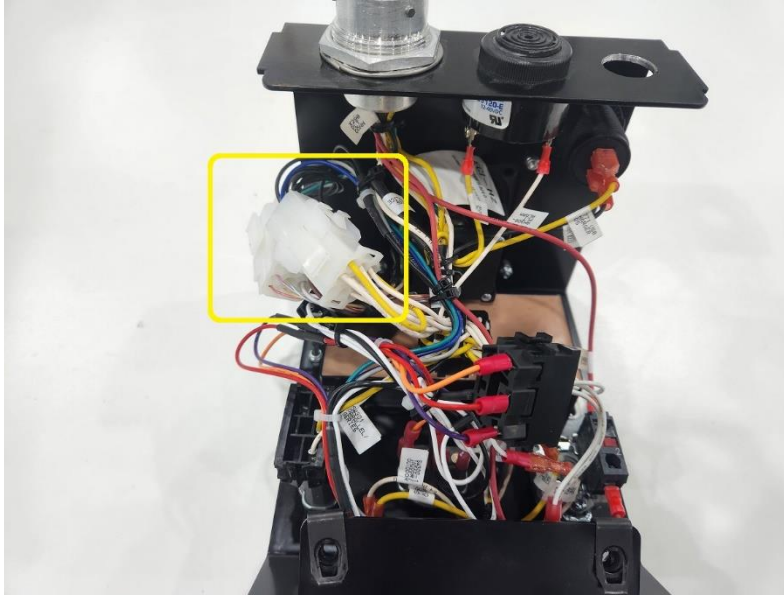

Control Module

Step	Description	Diagram
1.	Wiring connections are made with the AS001930 harness.	
2.	<p>Joystick Connection:</p> <p>Disconnect the 9-pin connector from the joystick and install the OverWatch harness in series.</p>	

3. **Horn Connection:**
 At the back of the horn switch, disconnect both yellow (SW299-2) and white (SW299-1) wires and install the OverWatch white wires with the spade and lug connectors.

Note: It doesn't matter which white wire is connected to which side.

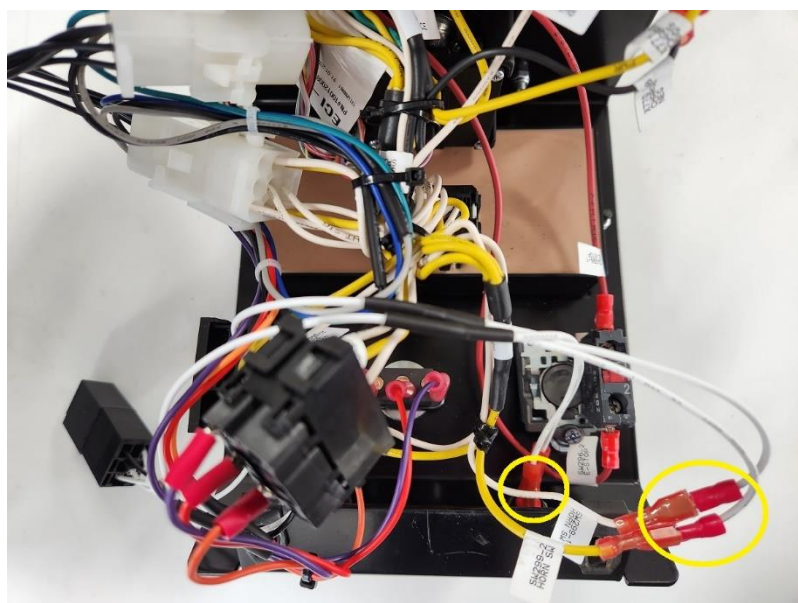

4. **Drive/Elevate and Power Connections:**
 At the back of the Drive/Elevate switch disconnect the **black** connector behind the switch and install the OverWatch purple, orange, and red wires with the spade and lug connectors as shown in the image.

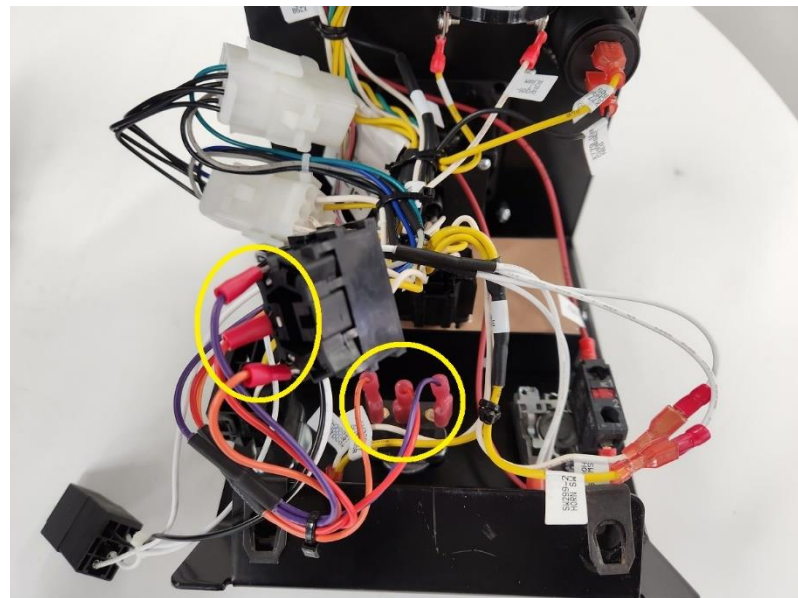

5. Mount the ECU module inside the metal enclosure by using the M4 screws and washers as shown in the image.

Connect the 8-pin connector from the operator sensor and the 12-pin connector from the OverWatch harness into the ECU module.

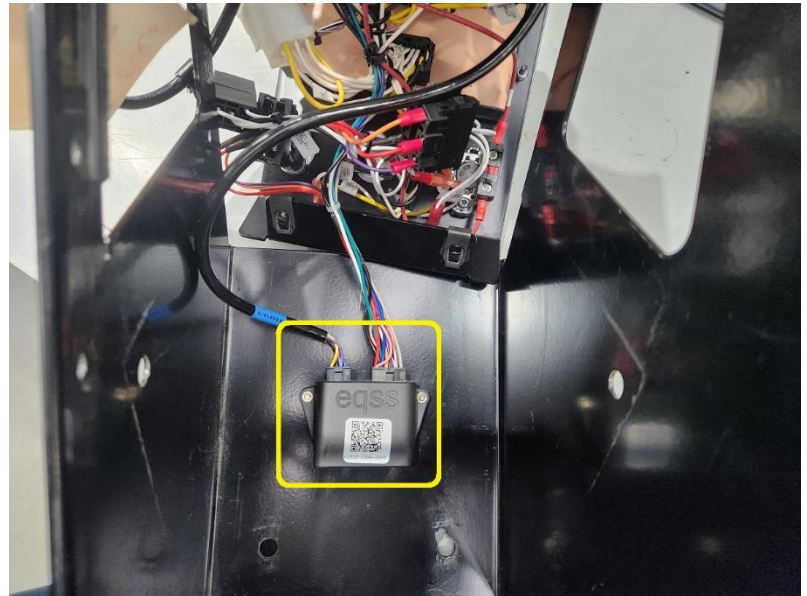

6. Re-assemble the control box. Make sure the operator sensor cable runs clear to the joystick enclosure and tighten the M20 gland to seal the entry point.



Post Installation Configuration

Overview

After the system has been installed it must be configured with the parameters to suit the machine. Follow the instructions below to configure the OverWatch.

Minimum system requirements

Any smart phone, tablet or laptop that meets the following requirements:

- The device can connect to a Wi-Fi access point
- The device has an up to date web browser installed. Firefox, Chrome or Safari are recommended.

Wi-Fi Connection & Web Page Access

To enable the Wi-Fi connection on the OverWatch to complete the configuration follow the steps below.

1. Power down the platform control box with the ESTOP
2. Wait 5 seconds
3. Power up the platform control box with the ESTOP
4. While standing **in front of the operator sensor**, switch on the OverWatch
5. As the welcome chime starts to play, cover the sensor. The LED will flash white then black to acknowledge.
6. Remove your hand from the sensor. The LED will flash white then black to acknowledge.
7. After covering then uncovering the sensor this way 2 more times, "Wi-Fi On" will be announced
8. On your Wi-Fi enabled device (laptop, tablet, smartphone, etc), show the available wireless networks
9. Select the wireless network (starts with "overwatch") to connect to the OverWatch
10. When prompted, enter the **password 12345678**
11. Open your preferred web browser (Chrome, Firefox, Safari)

Enter the following into the address bar <http://192.168.4.1> to open the OverWatch main page

Machine Model Selection

Follow the instructions below to configure the OverWatch.

1. Select the Setup option
2. If there is a password field at the bottom of the page, follow the instructions in Change Model Configuration to obtain the password and enter the password field
3. Select the EWP Model from the drop-down list and click Set
4. Click on Proceed to test to begin the installation test

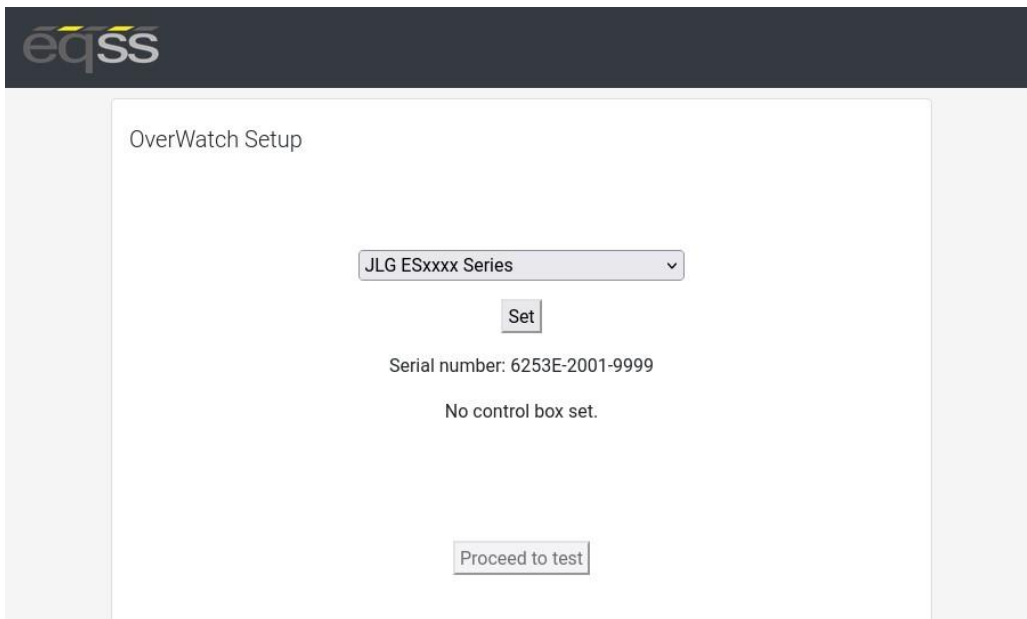

OverWatch Setup

JLG ESxxxx Series

Set

Serial number: 6253E-2001-9999

No control box set.

Proceed to test

Installation Test

After the model configuration has been set or updated an Installation Test must be performed. This will ensure the installation has been correctly performed and the OverWatch is functioning correctly. Follow the instructions on the web page to complete the Installation Test.

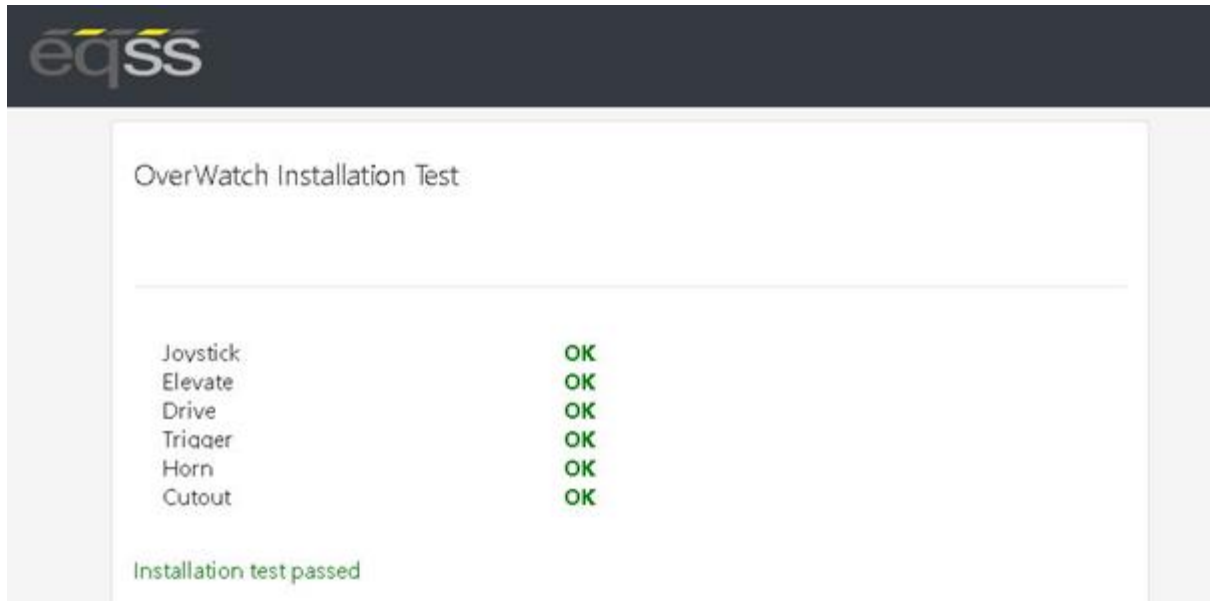

Change Model Configuration

To reconfigure the OverWatch for a different model requires an authorisation password. The authorisation password is generated from the EQSS website. The EQSS website requires a login username and password, contact EQSS for these details.

Follow the instructions below to obtain an authorisation password. It is important to note that each ECU has a unique serial number and a unique password.

1. Open your web and enter the following into the address bar <http://www.eqss.com.au/overwatch> to open the Login page
2. Enter your username and password
3. Enter the EUC serial number which is shown on the setup page or on the ECU serial number sticker, also enter the owner and model details of the EWP and then click Generate Hash
4. The generated Hash code or password can be used to change the model configuration.



The screenshot shows a web interface with the EQSS logo at the top left. Below the logo is a section titled 'Details' containing a table of user and system information.

Details	
Name	John Smith
Email	john.smith@company.com
Phone	+61 9 9999 9999
EQSS Overwatch Serial Number	6253E-2004-0000
Scissor Lift Model	JLG ESxxxx Series
Hash	50244

System Settings

Default Parameters

The OverWatch is configured with the following default parameters.

Setting Name	Description	Default
max_safe_velocity	This is the velocity threshold for the cutout in cm/s for drive mode.	100
max_safe_displacement	This is the maximum permitted distance in cm the operator may be away from the calibration position in drive mode.	50
max_safe_velocity_elevate	This is the velocity threshold for the cutout in cm/s for elevate mode.	80
max_safe_displacement_elevate	This is the maximum permitted distance in cm the operator may be away from the calibration position in elevate mode.	50
fwddispadj	The proportion of the calibration distance toward the sensor permitted to the operator.	0.6
fwdveloadj	The coefficient to apply to the maximum allowable velocity when the movement of the operator is toward the sensor.	1.0
zone_obstruction	If the lidar sensor reading is below this, the lidar is considered to be obstructed (with paint or thick coat of dust) and the system is cutout until the obstruction is cleared.	5
zone_minimum	The minimum calibration distance. If the operator is closer to the sensor than this "operator zone" will be announced.	10
zone_maximum	The maximum calibration distance. If the operator is further from the sensor than this "operator zone" will be announced.	120
adc_elevate_threshold	Threshold value for the elevate ADC input.	2000
adc_drive_threshold	Threshold value for the drive ADC input.	2000
adc_trigger_threshold	Threshold value for the trigger ADC input.	250
adc_joystick_fwd_threshold	Forward threshold value for the joystick ADC input.	1283
adc_joystick_bwd_threshold	Backward threshold value for the joystick ADC input.	1483
throttle_time	Period after the trigger is pressed (ms) during which initial velocity reading is computed.	500
driving_state_timeout	Mode selection switch timeout (ms)	7000

Polarity and Input Style

The table below describes each setting

Setting Name	Description	Default
joystick_drive_forward	Direction of joystick to move machine forward	forward
joystick_elevate_upward	Direction of joystick to move machine upwards	backward
elevate_polarity	Direction of signal logic	high
drive_polarity	Direction of signal logic	high
trigger_polarity	Direction of signal logic	high
joystick_polarity	Direction of signal logic	low
driving_state_input	Direct or timer based	direct

Replacement Parts

Replacement parts for this OverWatch kit are available from EQSS, please email sales@eqss.com.au

Shown below are the part numbers for the major components included in this model specific kit.

Part Number	Description
AS002325	OverWatch - Complete kit for JLG ESxxxx series
AS001910	OverWatch - Operator sensor with M20 gland
AS001916	OverWatch - Electronic Control Unit (ECU)
AS001930	OverWatch – JLG ESxxxx series harness
AS002326	OverWatch - Sensor guard V2
ME001818	OverWatch - L bracket 30/45